

Operation Manual

INKJET PRINTER

TS330-3200 DS

Operation Manual

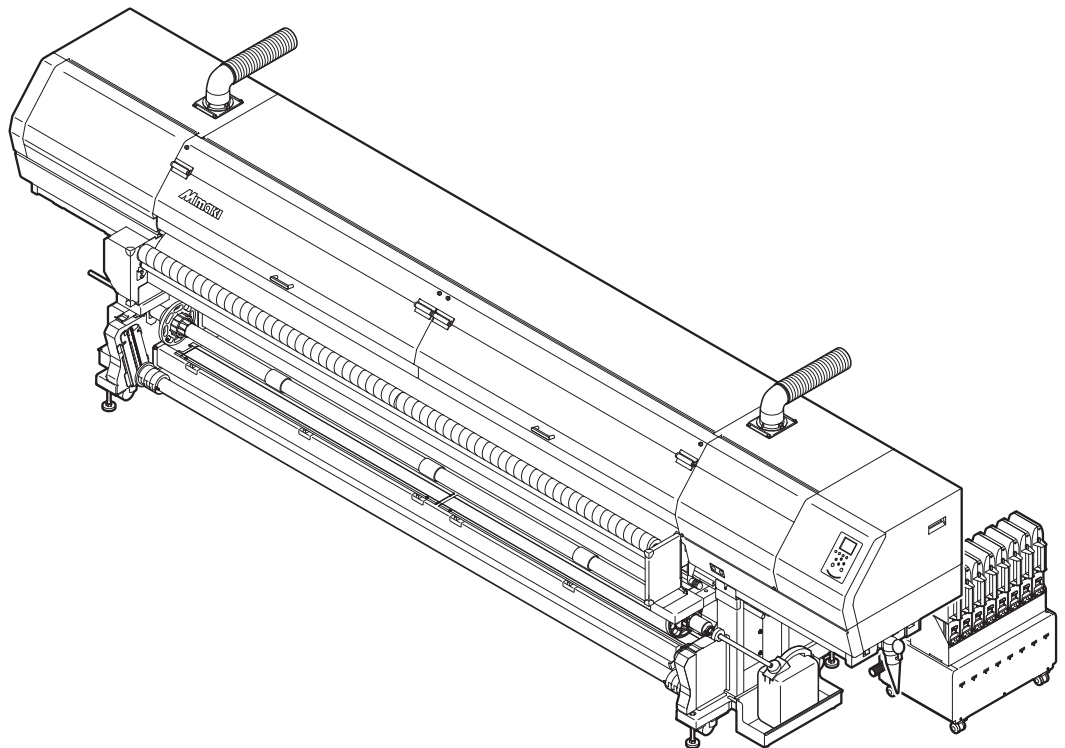

You can also download the latest manual from official website.

MIMAKI ENGINEERING CO., LTD.

<https://mimaki.com/>

D203845-11
Original instructions

TABLE OF CONTENTS

Introduction	6
To Ensure Safe Use	8
Symbols	8
Usage Precautions	9
Notes on Handling Ink or any Other Liquid Used with the Machine	13
Ink Specifications	14
Restrictions Concerning the Expiration Date of Ink Used in the Machine	15
Installation Precautions.....	16
Installation Space	17
When Relocating This Machine	17
Safety Interlocks	18
Warning Label.....	19

Chapter 1 Before Use

1.1 Part Names and Functions	22
Front	22
Rear and Right Side View.....	24
Ink Supply Unit.....	25
Carriage	26
Station.....	26
Flushing unit	26
Platen.....	27
Platen holder.....	27
Pinch Rollers and Grit Rollers.....	27
Media Sensor.....	28
Power Supply Switch	29
Operating Panel.....	30
1.2 Connecting the Power	33
Turning On the Power.....	34
Turning Off the Power.....	35
1.3 Connecting a PC to the Product	36
Using a LAN Cable	36
Using a USB Cable.....	37
1.4 System Configuration	38
Installing the Mimaki Driver.....	39
Installing RIP Software	39
Obtaining Color Profiles.....	39
Setting Up RIP Software.....	39
1.5 Ink Replacement Method.....	41
When Ink Near End is Displayed	41
When Ink End is Displayed.....	41
Replacing Ink	42

Chapter 2 Printing

2.1 Print Process	48
2.2 Print Preparation Workflow	51
2.3 Selecting the Platens	52
Holding the platens	52
Selecting cloth media platens	53
Selecting paper media platens	55
2.4 Attaching the Ink-Receiving Pan Spacers	58
2.5 Adjusting Print Head Height.....	60
2.6 Changing the Wiper	61
2.7 Preparing the Tension Roller	63
Adjusting the torque limiter	63
Attaching the cloth-wound roller	64
2.8 Preparing the Take-Up/Feed Tension Bars	67
2.9 Loading the Media	68
Media	68
Take-up unit.....	69
Feeding unit.....	72
Loading the Roll Media	73
Setting Leaf Media.....	85
Registering the Media.....	88
2.10 Setting the Heater Temperature	90
2.11 Test Printing.....	91
Changing the Layout Direction for Test Printing	91
Ejection Failures	92
2.12 Head Cleaning	93
2.13 Feed Correction	94
Feed Correction Procedure	94
2.14 Correcting the Drop Position.....	96
Drop Position Correction Procedure	96
2.15 Preparing RIP data	98
2.16 Printing.....	100
Changing the origin.....	100
Starting Printing	101
Stopping Printing (Data Clear).....	102

Chapter 3 Setup

3.1 Media Setting Menu.....	104
3.2 Maintenance Menu	107
Registering Nozzle Recovery	109
3.3 Function Setting Menu.....	111
3.4 Environment Setting Menu	113
3.5 Machine Status Menu	115

Chapter 4 Maintenance

4.1 Maintenance Precautions	118
4.2 Maintenance Methods	119
Maintenance Items and Timing	119
Ink Maintenance	120
Cap Rubber Cleaning	120
Carriage Underside Cleaning	121
Wiper Cleaning	122
Flushing Unit Cleaning	124
DAS (Automatic Correction Function) Sensor Cleaning	124
Ink-Receiving Pan Spacer Cleaning	125
Ink Slope Cleaning	126
Ink Discharge Channel Cleaning	126
Media Sensor Cleaning	127
Media Holder and Cloth Holder Cleaning	128
Jam Sensor Detecting Plate Cleaning	129
Platen and Platen Wire Cleaning	130
Pinch Roller and Grit Roller Cleaning	130
Tension Roller Cleaning	131
Cover (Exterior) Cleaning	132
When this Printer is Left Unused for a Long Time	132
4.3 Replacement of Consumable Item	135
Consumable Item Replacement Timing	135
Wiper Replacement	136
Wiper Cleaner Replacement	137
Cap Replacement	139
Replacing the Absorber Around the Station	141
Exhaust Fan Filter Replacement	144
Flushing Unit Absorber Pad Replacement	145
Pinch Roller Replacement	148
Media Holder and Cloth Holder Replacement	149
Ink Supply Unit Ink Absorber Replacement	155
Waste Ink Tank Replacement	156

Chapter 5 Troubleshooting

5.1 Troubleshooting	160
The power does not turn on	160
Printing is not possible	160
The media jams or the media is dirty	160
Image defects occur	161
The heater temperature does not rise to the specified value	163
The ink has leaked out	163
5.2 Problems Causing Messages to Appear	164
Warning Messages	164
Ink error	165
Error Message	166
SYSTEM HALT	172

Chapter 6 Appendix

6.1 Specifications.....	174
6.2 Options	177

Introduction

Thank you for purchasing the Inkjet printer TS330-3200DS.

Read this operating manual ("this document" hereinafter) thoroughly and make sure you understand its contents to ensure safe and correct use of the product.

Please note that the illustrations contained in this manual are intended to show functions, procedures, or operations and may sometimes differ slightly from the actual machine.

Adobe, the Adobe logo, Acrobat, Illustrator, Photoshop, and PostScript are the trademarks or registered trademarks of Adobe Incorporated in the United States and other countries.

RasterLink and TxLink are trademarks or registered trademarks of Mimaki Engineering Co. Ltd. in Japan and other countries.

Other company and product names mentioned herein are the trademarks or registered trademarks of the respective companies in Japan and in other countries.

Unauthorized reproduction of any portion of this document is strictly prohibited.

© 2024 MIMAKI ENGINEERING Co., Ltd.

● DISCLAIMERS

- MIMAKI ENGINEERING REJECTS ALL LIABILITY FOR DAMAGE ARISING DIRECTLY OR INDIRECTLY FROM THE USE OF THE TS330-3200DS ("THIS MACHINE" HEREINAFTER), WHETHER OR NOT THE PRODUCT IS FAULTY.
- MIMAKI ENGINEERING REJECTS ALL LIABILITY FOR DAMAGE, DIRECT OR INDIRECT, TO MATERIALS CREATED WHILE USING THIS MACHINE.
- USING THIS MACHINE IN CONJUNCTION WITH DEVICES OTHER THAN THOSE RECOMMENDED BY MIMAKI ENGINEERING MAY RESULT IN FIRE OR ACCIDENTS. SUCH INCIDENTS ARE NOT COVERED BY THE PRODUCT WARRANTY. MIMAKI ENGINEERING REJECTS ALL LIABILITY FOR DAMAGE, DIRECT OR INDIRECT, ARISING FROM SUCH INCIDENTS.
- USE ONLY GENUINE MIMAKI ENGINEERING INK AND MAINTENANCE LIQUID. USE OF OTHER PRODUCTS MAY RESULT IN FAILURES OR REDUCE PRINT QUALITY. SUCH INCIDENTS ARE NOT COVERED BY THE PRODUCT WARRANTY. MIMAKI ENGINEERING REJECTS ALL LIABILITY FOR DAMAGE, DIRECT OR INDIRECT, ARISING FROM SUCH INCIDENTS.
- DO NOT ATTEMPT TO REFILL THE INK PACKS WITH UNAUTHORIZED INK. SUCH INCIDENTS ARE NOT COVERED BY THE PRODUCT WARRANTY. MIMAKI ENGINEERING REJECTS ALL LIABILITY FOR DAMAGE, DIRECT OR INDIRECT, ARISING FROM SUCH INCIDENTS.

● TV and radio interference



- The machine emits high-frequency electromagnetic radiation while operating. Under certain circumstances, this may result in TV or radio interference. We make no guarantee that this machine will not affect special radio or TV equipment.
-

If radio or TV interference occurs, check the radio or TV reception after turning off the machine. If the interference disappears when the power is turned off, the machine is likely to be the cause of the interference.

Try any of the following solutions or combinations of these solutions:

- Change the orientation of the TV or radio antenna to find a position where interference does not occur.
- Move the TV or radio away from this machine.

● FCC (Federal Communications Commission) regulations

The machine has been tested and certified to comply with restrictions applying to Class A digital devices under Part 15 of the FCC regulations. These restrictions are designed to provide suitable protection from harmful interference when the printer is used in commercial environments.

This product may generate, use, or emit radio frequency energy and may cause harmful interference with radio communications if not installed or used in accordance with the operating manual.

Use of this product in residential areas may cause harmful interference. If so, the user is responsible for rectifying such interference.











- Use only the cables recommended by Mimaki Engineering when connecting to the machine. Use of other cables may cause the product to exceed the restrictions stipulated by FCC regulations. To maintain compliance with FCC regulations, use the cables recommended by Mimaki Engineering.
-

To Ensure Safe Use

Symbols

In this manual, symbols indicate and explain precautions. Make sure you fully understand the meaning of each symbol and use the machine safely and correctly.

Explanation		
	Warning	Indicates a potential hazard that may result in death or serious injury if handled improperly or if instructions are disregarded.
	Caution	Indicates a potential hazard that may result in minor or moderate injury if handled improperly or if instructions are disregarded.
	Notice	Indicates a potential hazard that may result in property damage if handled improperly or if instructions are disregarded.
	Warning sign	Indicates something that requires attention. Warning specifics are drawn inside the symbol.
	Mandatory action sign	Indicates an action that must be carried out. The specifics of the mandatory action are drawn inside the symbol.
	Prohibition sign	Indicates a prohibited action. The specifics of the prohibited action are drawn inside the symbol.
	Important	Indicates important information related to use of this machine.
	Tip	Indicates useful reference information.
	Reference information	Indicates the corresponding page for related information.

Usage Precautions

● In the event of abnormal conditions

WARNING



- In the event of abnormal conditions such as smoke or unusual odor, turn off the main power immediately and turn off the breaker. Continuing to use the machine under these conditions may result in failure, electric shock, or fire. Once you have confirmed that smoke is no longer being emitted, contact your local dealer or our service office. Never attempt to repair the machine yourself, which is hazardous.

CAUTION



- Immediately wipe off any ink, maintenance liquid, waste ink, or other liquid used with the product that comes into contact with your skin. Then wash using soap, and rinse with plenty of water. Failure to wash off ink may result in skin inflammation. If your skin becomes irritated or painful, seek medical attention immediately.
- If ink, maintenance liquid, waste ink, or any other liquid used in the product comes into contact with your eyes, rinse immediately with plenty of clean water. Rinse for at least 15 minutes. If you wear contact lenses and they can be easily removed, remove after rinsing for at least 15 minutes with clean water. Be sure to also rinse the undersides of your eyelids. Failure to rinse off ink may result in blindness or impaired vision. If your eyes become irritated or painful, seek medical attention immediately.
- If ink, maintenance liquid, waste ink, or any other liquid used in the product enters your mouth or is swallowed, gargle with water immediately. Do not induce vomiting. Seek medical attention promptly. Inducing vomiting may cause liquid to enter the airway.
- If a large amount of vapor is inhaled, move to a well-ventilated area, keep warm, and rest in a posture that allows easy breathing. If the condition does not improve, seek medical attention promptly.

NOTICE



- If an ink leak occurs, turn off the main power immediately and turn off the breaker. Then, contact your local dealer or our service office.

● Power supply precautions

WARNING



- Do not damage or modify the power cable. Do not place heavy objects on, heat or stretch it. Doing so may damage the cable, leading to electric shock or fire.
- Do not use the power cable if it is damaged or broken or if the core wire is exposed. Otherwise there is a risk of failure, electric shock, or fire.



- Always connect the machine to a switchboard with grounded polarity. Otherwise there is a risk of failure, electric shock, or fire. All electrical work (Class C grounding work; formerly Type 3 grounding work) must be handled by a licensed electrician.

NOTICE



- Do not turn off the main power supply. Turning off the main power supply will disable the automatic maintenance function (including nozzle clogging prevention function and ink discharge channel cleaning function). This increases the risk of ejection failures (such as nozzle clogging or deflection).

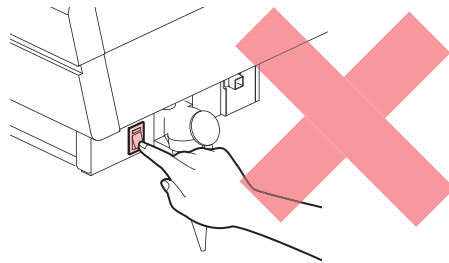

- Use the machine with a power supply that meets specifications.
- When connecting the power cable, check the input voltage of the power outlet and the capacity of the breaker. Also, connect each cable to a separate power source with an independent breaker. Connecting to power outlets linked with the same breaker will cause the breaker to trip.

● Caution regarding moving parts

⚠ CAUTION



- Keep parts of the body such as the face and hands away from moving parts. Also keep clothing (e.g., loose clothing and accessories) that may impede work away from the machine. Failure to do so may result in injury.



- Long hair should be tied back. Failure to do so may result in injury.

● Do not disassemble or repair

⚠ WARNING



- Do not attempt to disassemble or repair this machine. Otherwise there is a risk of failure, electric shock, or fire.

● Heater

⚠ CAUTION



- The heater becomes extremely hot. Do not touch with bare hands.

NOTICE



- Condensation may form on the print head nozzle surface depending on the ambient temperature and humidity. The formation of condensation may cause ejection failures (e.g., nozzle clogging or deflection). Perform head cleaning if any ejection failures (e.g., nozzle clogging or deflection) occur during printing.  ["Head Cleaning"\(P. 93\)](#)

● Other usage precautions

⚠ WARNING



- Keep children away from the machine.

NOTICE



- Do not pull the media when the clamp lever is lowered (the media is clamped). Doing so may damage the machine.



- The underside of the media may be soiled depending on how the printed media has been stored (due to weight when laying printed media rolls horizontally, for example) and the media type. Perform a test beforehand to check that the media does not transfer ink to the underside of the adjacent media.

● Disposing of the product

⚠ CAUTION



- Please contact your local retailer or service agent.
 - When disposing of the product yourself, contact an industrial waste disposal operator or dispose of the product in accordance with local laws and regulations.
-

Notes on Handling Ink or any Other Liquid Used with the Machine

Precautions regarding ink, maintenance liquid, or other liquids used with this machine are included with the containers. Thoroughly read them and make sure you understand the contents.



- Be sure to read the safety data sheet (SDS) before use. <https://mimaki.com/supply/sds/>

CAUTION



- Pay close attention to ventilation and be sure to wear safety glasses, gloves, and a mask when handling ink, maintenance liquid, waste ink, or other solutions used with the machine. Leaking ink may adhere to the skin or get into the eyes or mouth.



- Do not subject cases containing ink to strong shock or violent shaking. Do not attempt to refill the ink. Leaking ink may adhere to the skin or get into your eyes or mouth.



- Do not disassemble cases containing ink. Leaking ink may adhere to the skin or get into your eyes or mouth.



- Do not store ink, maintenance liquid, or other liquids used with the machine in locations where children may enter.



- When disposing of ink, maintenance liquid or other liquid used with the product, or containers or non-woven fabric contaminated with ink or other liquid, contact an industrial waste disposal operator or dispose of the product in accordance with the local laws and regulations.

NOTICE



- Do not store ink, maintenance liquid, or other liquids used with the machine in locations exposed to direct sunlight.
- Do not store ink, maintenance liquid, or other liquids used with the machine in environments where cutting fluid or other volatile substances (such as amines or modified amine alcohol) are present in significant quantities. Storage in such places increases the risk of failure or ejection failures (e.g., nozzle clogging or deflection).
- Do not use ink, maintenance liquid, or other liquids used with this machine with other printers. Doing so may cause failure.



- Be sure to store them in a low place no higher than 1 m above the floor. Otherwise there is a risk of scattering if the containers fall.
- Store in tightly sealed containers.
- Store in a cool, dark place.
 - (1) Store ink in a place where ink does not freeze. Using defrosted ink may deteriorate ink constituents and reduce print quality.
 - (2) When ink is moved from a cold place to a warm place, leave it in the environment where the machine is installed for at least three hours before using it.
 - (3) Open the container just before installing it, and use it up as quickly as possible. If it is opened and left for an extended period of time, print quality may be reduced.



- Do not touch the metal parts of the ink IC chip. Static electricity may damage the ink IC chip, and dirt or damage may cause the ink IC chip read error.



- Printing is disabled if a different ink IC chip is used.

Ink Specifications

Item		TS330-3200DS
Type		Special sublimation transfer ink Sb411, Special sublimation dye ink Sb420 (Mimaki Engineering product)
Color		Blue (BL) Magenta (M) Yellow (Y) Black (K)
Form		Aluminum pack, ink tank ^{*1}
Ink capacity		2,000 ml, 10,000 ml ^{*1}
Expiration date		As indicated on the ink pack. However, after opening, it should be consumed within one month, even if before the expiration date.
Storage temperature ^{*2}	When stored	10 to 35 °C (daily mean temperature) • Ink quality may deteriorate if stored outside these conditions.
	During transportation	0 to 40 °C • Ink quality may deteriorate if stored outside these conditions.

*1. Depends on options.

*2. Ink quality may deteriorate if stored outside this temperature range.

Restrictions Concerning the Expiration Date of Ink Used in the Machine

Example: When the expiration date is April 20xx

- May 20xx: Replace with new ink or use up as quickly as possible. Printing is possible.
- June 20xx: Replace with new ink or use up as quickly as possible. Printing is possible.
- July 20xx: Printing is not possible.



- The message appears on the display.



- The ink expiration date is indicated on the ink container. Expired ink may cause ejection failures or alter the color tone. Printing is possible even if the ink has passed its expiration date. Nevertheless, we recommend replacing with new ink or using up as quickly as possible.
-

Installation Precautions

WARNING



- Do not install the machine in a place close to fire.
- Do not place flower vases, pots, cups, containers containing cosmetics, chemicals or water, or small metal items on or close to the machine. If they enter the machine, there is a risk of failure, electric shock, or fire.



- Do not install this machine in humid locations or locations where it may be exposed to splashing water. Otherwise there is a risk of failure, electric shock, or fire.



- Do not install the machine in a place where children may enter.

CAUTION



- A ventilation system must be provided if the machine is installed in a poorly ventilated area or sealed room.
- Be sure to observe the following points regarding exhaust port installation:
 - (1) Exhaust port installation must conform to local environmental, health, and safety (EHS) guidelines.
 - (2) If the exhaust port is fitted with a shutoff valve, the valve must be open when the machine is in use.



- Two mist exhaust units are provided on the top face of the machine. For the exhaust equipment to be connected to the exhaust ducts, please check the exhaust duct specifications provided with the machine below and make the necessary preparations by the customer.
 - (1) Inner diameter: $\phi 100$ mm
 - (2) Length: 1 m (maximum 3 m when extended)

NOTICE



- Do not install this machine in locations where dust or powder is present. Failure or printing defects may result (e.g., nozzle clogging, deflection) if dust gets inside this machine.
- Do not install this machine in locations exposed to drafts (e.g., from air conditioning). Disregarding this precaution may result in dust or powder getting inside this machine.
- Do not install this machine in unstable locations or locations subject to vibration. This will increase the risk of failure or printing defects (e.g., nozzle clogging, deflection).
- Do not install this machine in locations exposed to direct sunlight.
- Do not install this machine in locations subject to sudden temperature changes. This will increase the risk of failure or printing defects (e.g., nozzle clogging, deflection).
- Do not install this machine in locations exposed to excessive noise from large machinery.
- Do not install this machine in locations where photographic fixing agents generate vapor or acid gas (e.g., acetic acid, hydrochloric acid) or locations filled with metal working fluids or highly volatile substances (e.g., amines, amine-modified alcohols). Malfunctions or printing defects may result (e.g., nozzle clogging, deflection) as print head ink is more likely to harden under such environments.



- Operating environment: 20 to 30 °C (68 to 86 °F), 35 to 65 %RH (no condensation)
- Temperature range in which accuracy is guaranteed: 20 to 25 °C (68 to 77 °F)

Installation Space

Provide the following space around the machine to allow safe and proper replacement of ink and media:

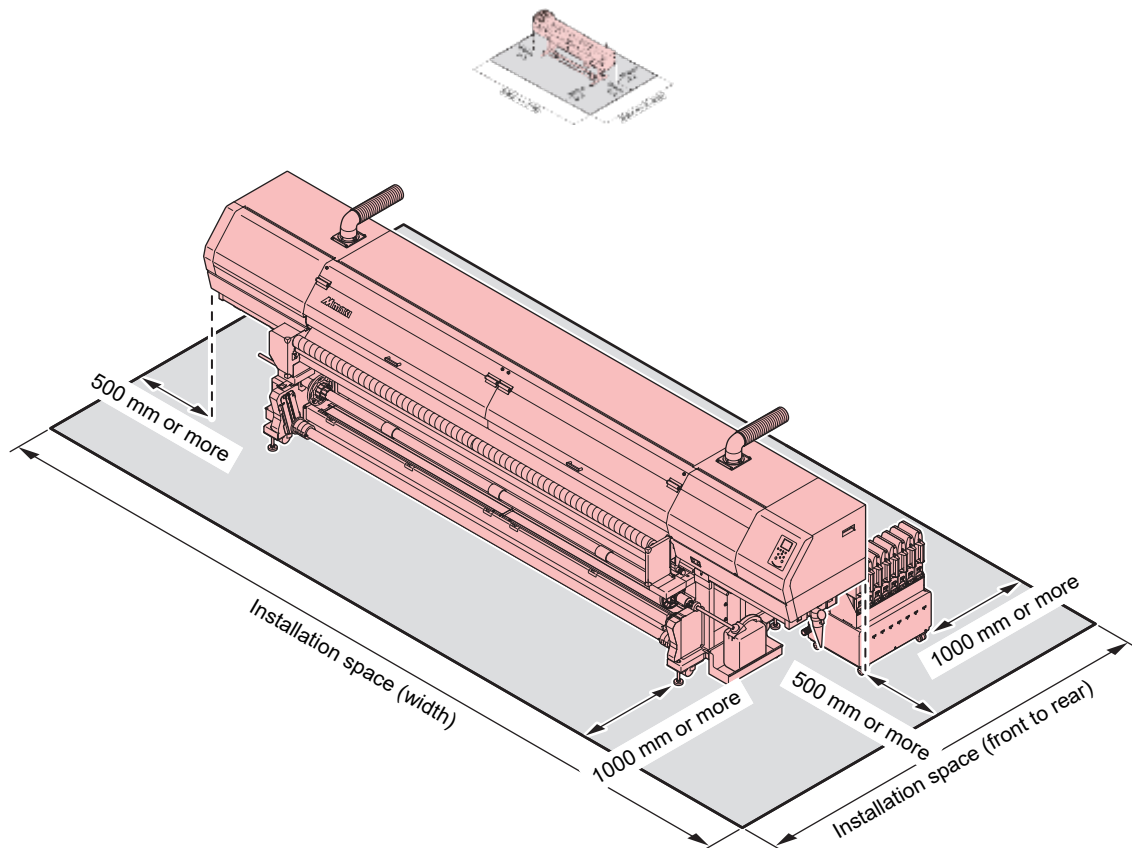

● TS330-3200DS

Size	TS330-3200DS
Width ^{*1}	At least 6,500 mm (5,410 mm)
Depth ^{*1}	At least 3,100 mm (1,075 mm)
Height ^{*1}	(1,650 mm)
Weight	Main unit: 925 kg, external supply unit: 43 kg

*1. The figures in parentheses indicate machine dimensions.

When Relocating This Machine

Contact your local dealer or our service office. Attempting to handle relocation yourself may result in failure or damage.

Safety Interlocks

The machine is equipped with interlocks to ensure safety during use.

Printing will abort if you open the covers while printing is underway. The RIP data will need to be resent.

- Safety interlock locations

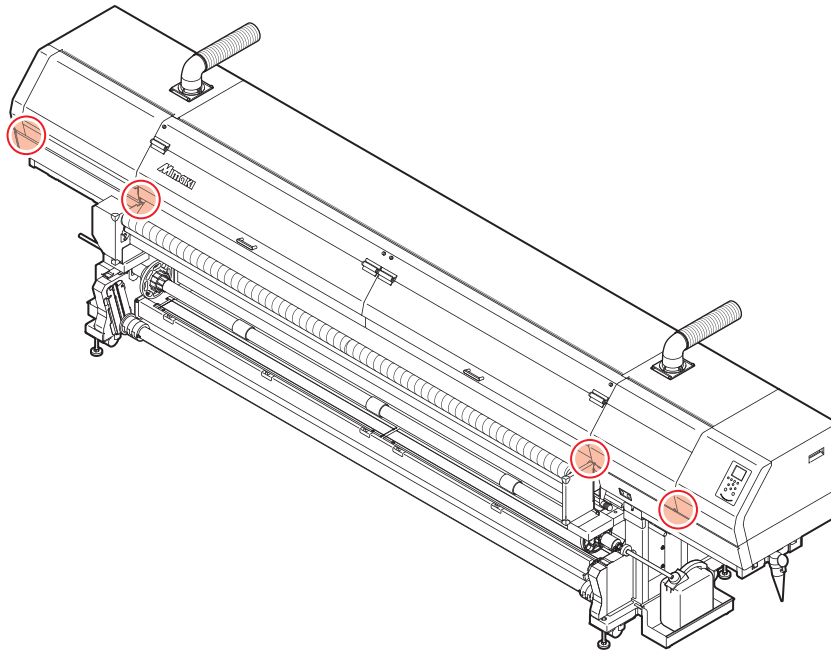







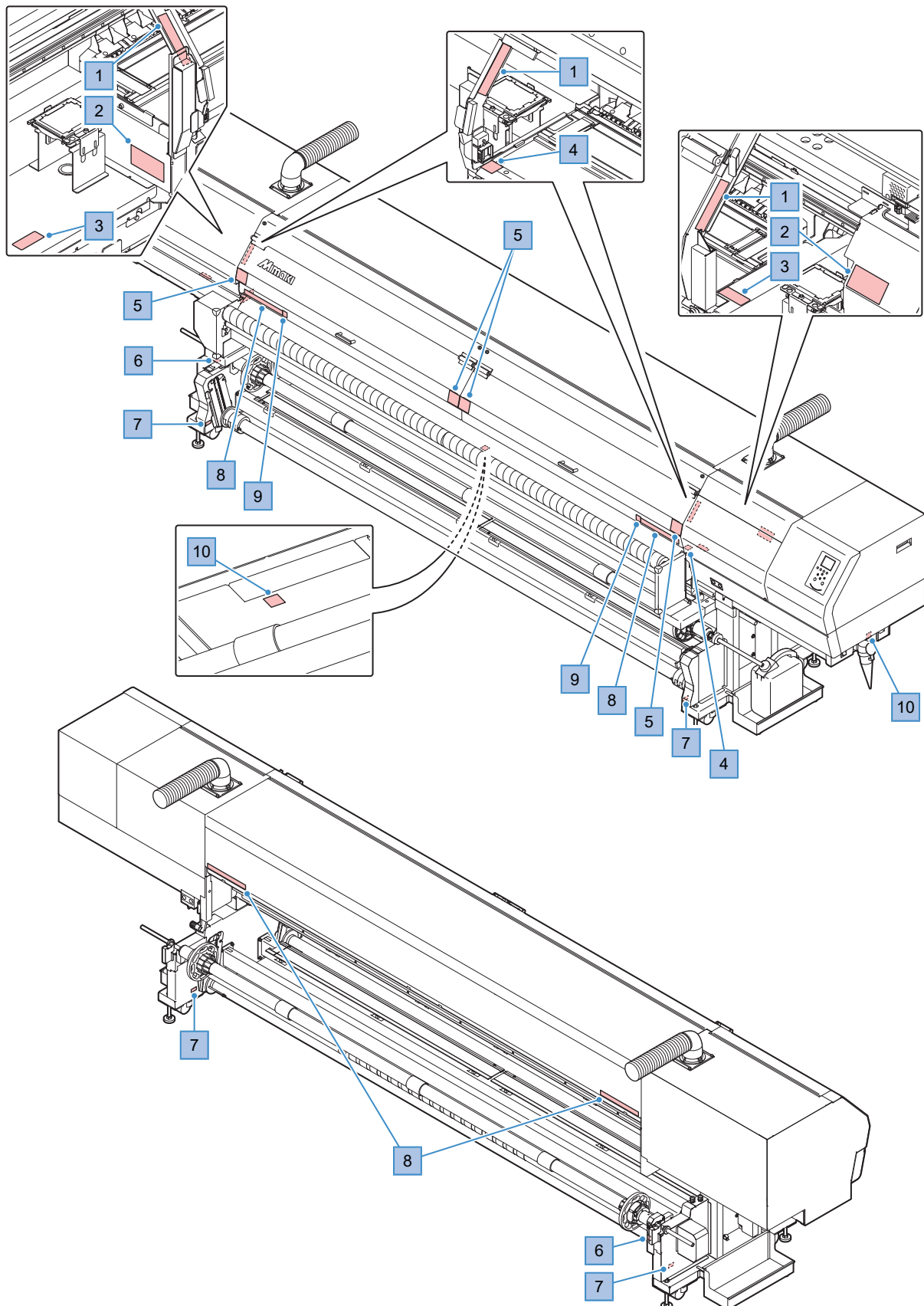



Warning Label

Make sure you fully understand the details indicated on the various warning labels.

If any of the warning labels becomes dirty and illegible or peel off, contact your local dealer or our service office to request new warning labels.



No.	Order code	Label	Details
1	M912523		Indicates dangerous moving parts.
2	M912522	 <p>DO NOT put hands and arms into the carriage moving area. N'inserez pas vos doigts ni vos bras dans le champ de déplacement du chariot. キャリッジ可動範囲内に指、腕などを 入れないこと</p>	Indicates dangerous moving parts.
3	M903330		Wear safety glasses and gloves while working.
4	M903239		Indicates hot parts.
5	M910931	 <p>COVER HAZARD May result in severe injury. When open and close the cover, hold a cover until the end. COUVERCLE-DANGER Peut entraîner de graves blessures. Lors de l'ouverture ou de la fermeture du couvercle, tenir le couvercle jusqu'à la fin. カバー急落下あり 指を挟まれると、ケガや骨折の恐れあり。 カバーの開閉は、最後まで手を添えて行ってください。</p>	Beware of opening and closing parts. Injury may result if hands become trapped.
6	M905811		Indicates dangerous moving parts. (Cut from the No. 8 label.)
7	M912054		Indicates dangerous moving parts.
8	M905811	 <p>警告 警告 WARNING WAARSCHUWING AVERTISSEMENT 手指和身体請勿靠近運 危險な移動部 HAZARDOUS MOVING PARTS GEFAHRLICHE BEWEGLICHE TEILE PIÈCES MOBILES DANGEREUSES 送部位。以免造成危險 指や体近づかないように Keep fingers and other body parts away. Finger und andere Körperteile fernhalten. Doigts et autres parties du corps sont hors de portée.</p>	Indicates dangerous moving parts.
9	M907833		Indicates dangerous moving parts.
10	M907935		Indicates dangerous live parts.

Chapter 1 Before Use



This chapter

This chapter describes information essential before use, such as part names.

Part Names and Functions	22	Connecting the Power	33
Front.....	22	Turning On the Power	34
Rear and Right Side View	24	Turning Off the Power	35
Ink Supply Unit.....	25	Connecting a PC to the Product.....	36
Carriage	26	Using a LAN Cable	36
Station.....	26	Using a USB Cable	37
Flushing unit.....	26	System Configuration	38
Platen	27	Installing the Mimaki Driver	39
Platen holder	27	Installing RIP Software.....	39
Pinch Rollers and Grit Rollers	27	Obtaining Color Profiles	39
Media Sensor	28	Setting Up RIP Software	39
Power Supply Switch	29	Ink Replacement Method	41
Operating Panel	30	When Ink Near End is Displayed	41
		When Ink End is Displayed	41
		Replacing Ink	42

1.1 Part Names and Functions

Front

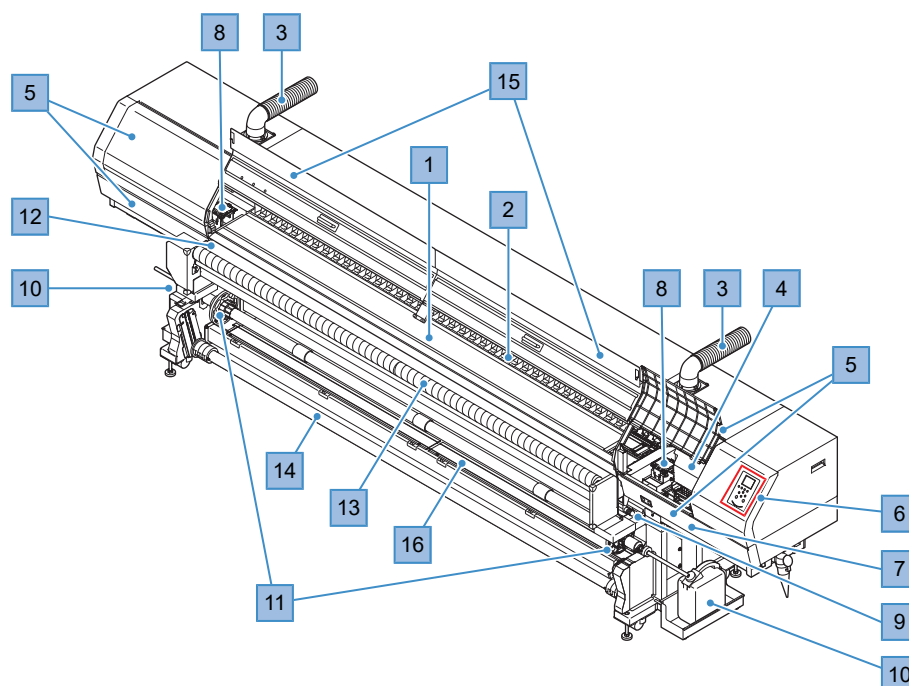

No.	Name	Overview
1	Platen	Print area. "Platen"(P. 27)
2	Pinch roller Grit roller	The pinch rollers and grit rollers are used to grip and feed the media. "Pinch Rollers and Grit Rollers"(P. 27)
3	Mist exhaust unit	Mist generated during printing is discharged from the exhaust unit to an exhaust system or other equipment.
4	Carriage	Consists of components such as the print head and jam sensor. "Carriage"(P. 26)
5	Maintenance cover	Open the cover to perform maintenance on locations such as the carriage underside. Printing and automatic maintenance are not possible while the covers are open.
6	Operating Panel	Includes operating keys and displays indicating various settings and other items. "Operating Panel"(P. 30)
7	Station	Includes caps and wipers for protecting print heads. "Station"(P. 26)
8	Flushing unit	Periodically ejects ink to the flushing unit to prevent head ink clogging. "Flushing unit"(P. 26)
9	Clamp lever	Lowering the clamp lever secures the media. Raising the clamp lever releases the media. Linked to the clamp lever at the rear.
10	Waste Ink Tank	Container for waste ink. "Waste Ink Tank Replacement"(P. 156)
11	Take-up unit	Rolls up the printed roll media. "Take-up unit"(P. 69)
12	Post-heater	Allows ink to dry after printing. Adjust the temperature setting to suit the type of media used. "Setting the Heater Temperature"(P. 90)
13	Tension roller	Roller for feeding the media.
14	Tension bar (take-up)	Used to keep the media under tension.

No.	Name	Overview
15	Front cover	Open the cover for loading the media, performing maintenance on the area around the platen, and for replacing consumable items. Printing and automatic maintenance are not possible while the covers are open.
16	Platen holder	Used to store the platen detached when printing on cloth media.  "Platen holder"(P. 27)

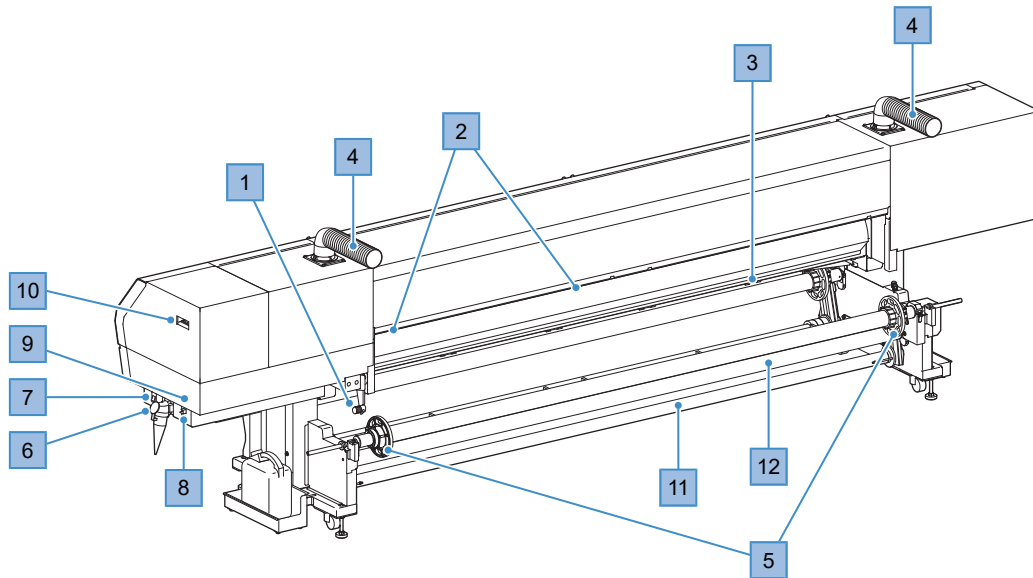

Rear and Right Side View

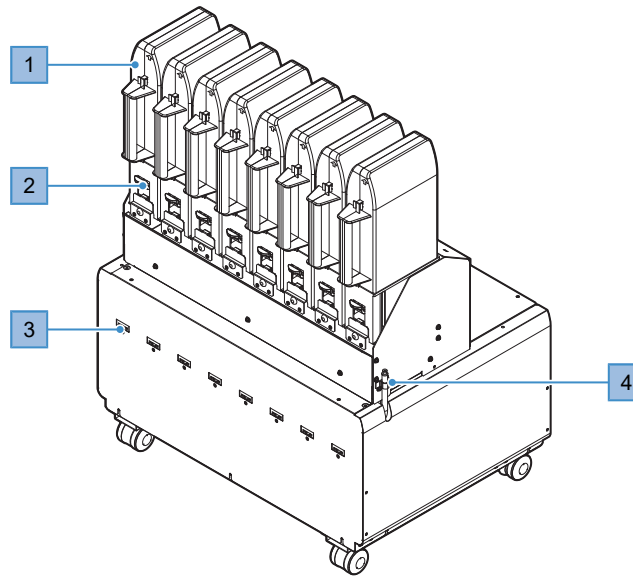

No.	Name	Overview
1	Clamp lever	Linked to the clamp lever at the front.
2	Media Sensor	Detects whether media is present. 🖱️ "Media Sensor"(P. 28)
3	Exhaust fan BOX	Discharges air for holding down the media.
4	Feeding unit	Compatible with 3-inch paper cores. Allows one roll media to be loaded. 🖱️ "Feeding unit"(P. 72)
5	AC inlet	Use the power cable provided. 🖱️ "Connecting the Power"(P. 33)
6	Main power switch	The main power supply for the machine. To prevent ejection failures attributable to the print head (e.g., nozzle clogging or deflection), do not turn off the main power supply. 🖱️ "Power Supply Switch"(P. 29) 🖱️ "Turning On the Power"(P. 34) 🖱️ "Turning Off the Power"(P. 35)
7	LAN port	Connects to PC via a LAN cable. 🖱️ "Using a LAN Cable"(P. 36)
8	USB port	Connects to PC via a USB interface cable. 🖱️ "Using a USB Cable"(P. 37)
9	Maintenance liquid cartridge	Used to automatically feed maintenance liquid to the cap, and to prevent ink solidifying inside the ink discharge channel during maintenance.
10	Tension bar (feed)	Used to keep the media under tension.
11	Return shaft	Used to secure the media to the return shaft.

Ink Supply Unit



No.	Name	Overview
1	Ink Eco-case	The ink eco-cases are mounted here.  P. 42
2	Ink lever	Push down the lever to remove the ink eco-cases.  P. 42
3	Ink IC chip slot	For inserting the ink IC chips provided with the ink.  P. 42 This manages the ink information.
4	Ink leak check tube	If ink enters the tube, contact your local dealer or our service office.

Carriage

The carriage includes a print head for ejecting ink, and a jam sensor for stopping the carriage when media clogs. Printing occurs as ink is ejected while traversing left and right.

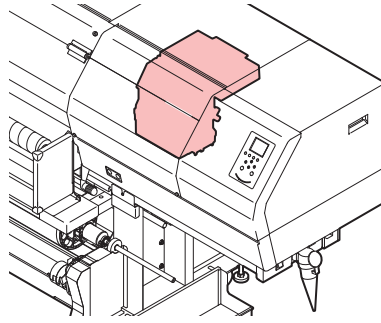

Station

The station includes a cap for preventing the print head nozzle surface from drying out, and a wiper required for print head maintenance.

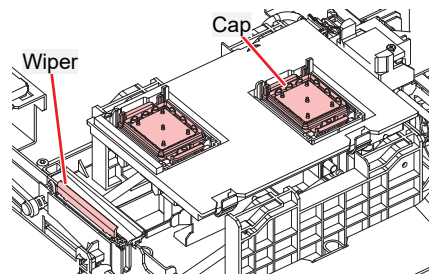

Flushing unit

Periodically ejects ink to the flushing unit to prevent head ink clogging. Located on the left and right sides (2 locations).

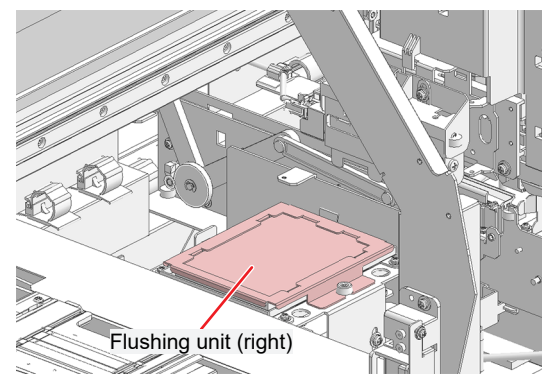
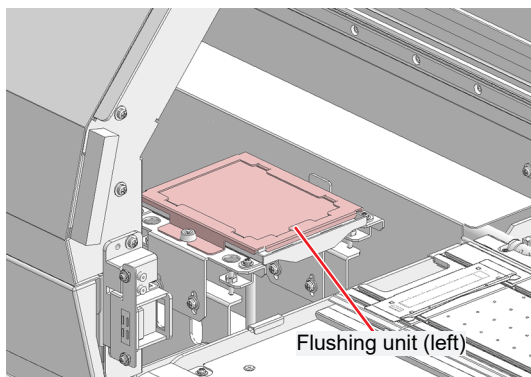

Platen

Print area. The platen secures the media under vacuum pressure. The platen is used when printing on paper media. The platen is removed when printing on cloth media. (The platen is removable.)

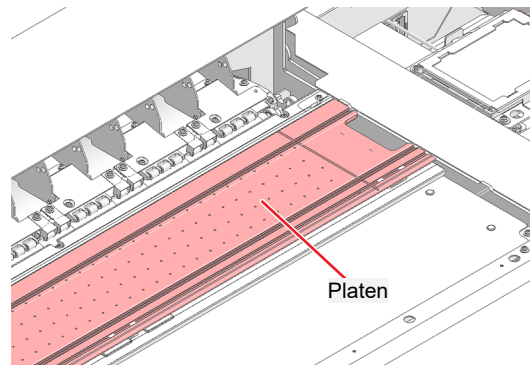

Platen holder

When printing on cloth media, the platen is removed and stored in the platen holder.

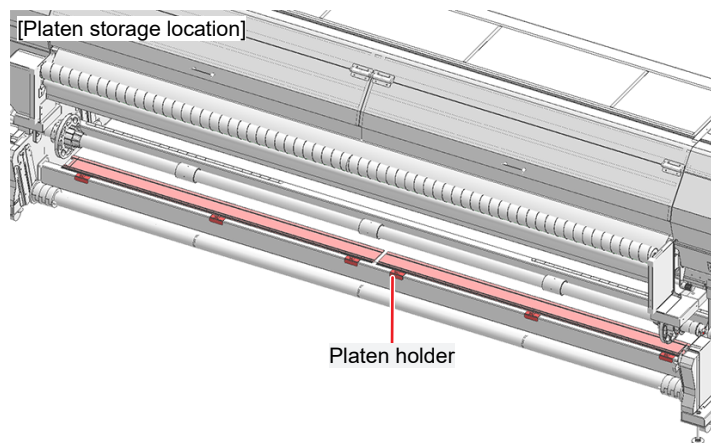

Pinch Rollers and Grit Rollers

The pinch rollers and grit rollers are used to grip and feed the media.

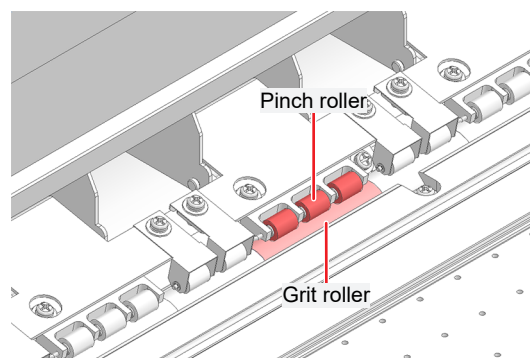

When the machine is not in use, raise the clamp lever to **separate the pinch rollers from the grit rollers**.

- Leaving the pinch rollers lowered may cause them to become deformed and prevent media from being fed correctly.
- Leaving media loaded will subject it to force from the pinch rollers, which may leave pinch roller marks on it.

Media Sensor

The media sensor detects the presence/absence of media. The sensor must be covered by the media to detect the media width. Two sensors are located on top of the pre-cover (at the rear).

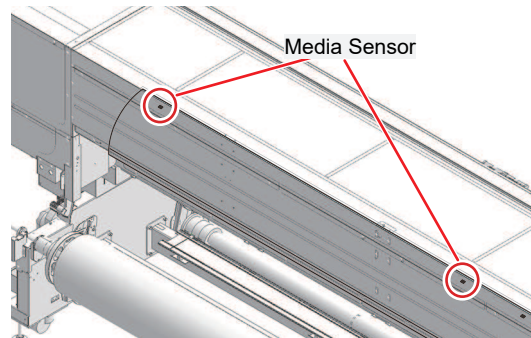

Power Supply Switch

● Main power switch

This is located on the right-hand side at the front of the machine.

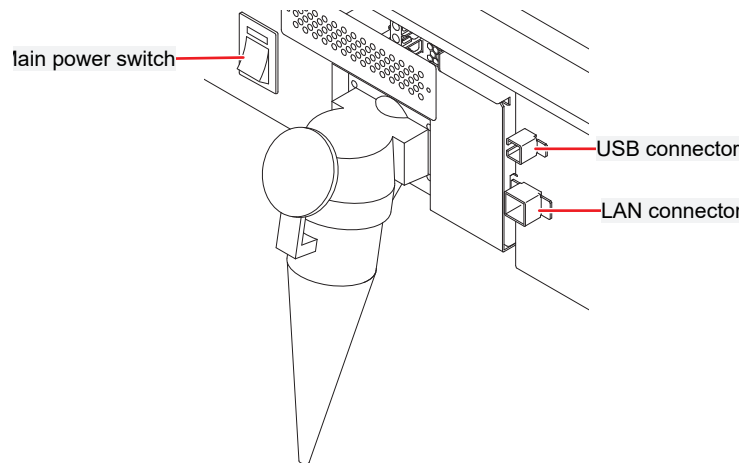

- Do not turn off the main power supply. Turning off the main power supply will disable the automatic maintenance function (including nozzle clogging prevention function and ink discharge channel cleaning function). This increases the risk of ejection failures (such as nozzle clogging or deflection).

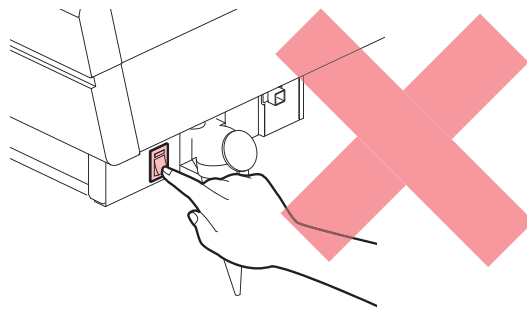

● [END/POWER] key

The [END/POWER] key is the key normally used to turn the power on and off.

To turn off the power, hold down the [END/POWER] key. Press the [ENTER] key once the instructions appear on the display.

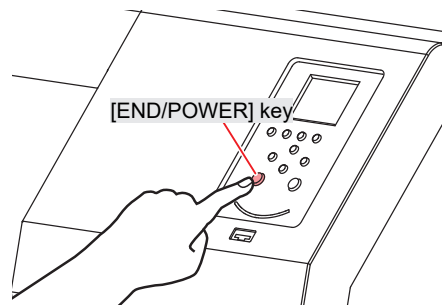

Operating Panel

This is used to control the product and make/change settings.

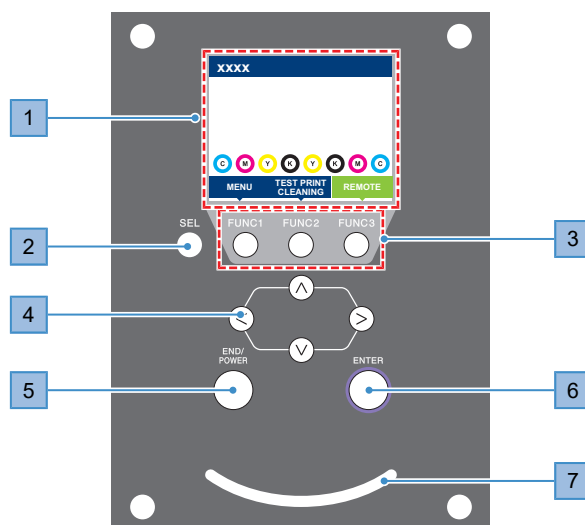

No.	Name	Overview																				
1	Display	"Display"(P. 31)																				
2	[SEL] key	Selects the function for the corresponding [FUNCTION] key.																				
3	[FUNCTION] key	Used for test printing, head cleaning, and editing settings. "[FUNCTION] key"(P. 32)																				
4	[JOG] key ▲▼◀▶	Used to move the carriage, feed media, and select settings																				
5	[END/POWER] key	Used to cancel the last setting entered, return to the previous level of the setting menu, or to turn power on and off <ul style="list-style-type: none"> • Illuminates in blue when the power is on. "Turning On the Power"(P. 34) • To turn off the power, hold down the key. "Turning Off the Power"(P. 35) 																				
6	[ENTER] key	Used to move to the next level menu and to confirm settings. This can also be used to display product information. "Displaying Machine Information (Local Guidance)"(P. 32)																				
7	Status lamp	This lamp indicates the machine status. <table border="1"> <tbody> <tr> <td>Off</td> <td></td> <td>Indicates LOCAL mode. Used for test printing, maintenance, and settings</td> </tr> <tr> <td rowspan="2">Light blue</td> <td>Illuminated</td> <td>Indicates REMOTE mode. The product is in standby to receive print data.</td> </tr> <tr> <td>Flashing</td> <td>Indicates that printing is in progress. This also flashes to indicate test printing—for example, when printing built-in patterns.</td> </tr> <tr> <td>Blue</td> <td>Illuminated</td> <td>Indicates that data remains to be printed. Switch to REMOTE mode and start printing</td> </tr> <tr> <td>Green</td> <td>Flashing</td> <td>Indicates that maintenance is underway. Some functions will be limited until maintenance has ended.</td> </tr> <tr> <td>Yellow</td> <td>Flashing</td> <td>Ink Near End status (very little ink remains). "When Ink Near End is Displayed"(P. 41)</td> </tr> <tr> <td>Red</td> <td>Flashing</td> <td>An error has occurred. Refer to the error code list and take appropriate action. "Error Message"(P. 166)</td> </tr> </tbody> </table>	Off		Indicates LOCAL mode. Used for test printing, maintenance, and settings	Light blue	Illuminated	Indicates REMOTE mode. The product is in standby to receive print data.	Flashing	Indicates that printing is in progress. This also flashes to indicate test printing—for example, when printing built-in patterns.	Blue	Illuminated	Indicates that data remains to be printed. Switch to REMOTE mode and start printing	Green	Flashing	Indicates that maintenance is underway. Some functions will be limited until maintenance has ended.	Yellow	Flashing	Ink Near End status (very little ink remains). "When Ink Near End is Displayed"(P. 41)	Red	Flashing	An error has occurred. Refer to the error code list and take appropriate action. "Error Message"(P. 166)
Off		Indicates LOCAL mode. Used for test printing, maintenance, and settings																				
Light blue	Illuminated	Indicates REMOTE mode. The product is in standby to receive print data.																				
	Flashing	Indicates that printing is in progress. This also flashes to indicate test printing—for example, when printing built-in patterns.																				
Blue	Illuminated	Indicates that data remains to be printed. Switch to REMOTE mode and start printing																				
Green	Flashing	Indicates that maintenance is underway. Some functions will be limited until maintenance has ended.																				
Yellow	Flashing	Ink Near End status (very little ink remains). "When Ink Near End is Displayed"(P. 41)																				
Red	Flashing	An error has occurred. Refer to the error code list and take appropriate action. "Error Message"(P. 166)																				

No.	Name	Overview	
		Illuminated	A system error (SYSTEM HALT) has occurred. Contact our service office. "SYSTEM HALT"(P. 172)

Display

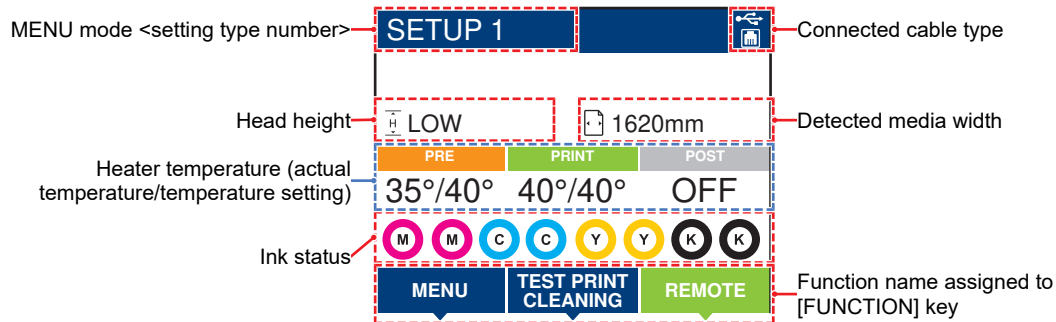

● Heater temperature

The heater status is indicated by different colors.

- Orange: Adjusting to temperature setting.
- Green: At temperature setting.
- Gray: Heater is turned off.

MENU mode

Four menu modes are available.

Name	Overview
LOCAL mode	Used for test printing, maintenance, and settings
REMOTE mode	Prints the print data received from a PC.
MENU mode	Press the [MENU] on the LOCAL mode screen to switch to MENU mode. This is used to set various functions.
NOT-READY mode	Status before media is detected















Ink status

The ink pack status such as remaining ink levels and ink errors are indicated by icons.

Icon	Overview					
	Displays remaining ink levels using a 9-stage icon.					
	Full 1/8 used 1/4 used 3/8 used 1/2 used 5/8 used 3/4 used 7/8 used					
	Very little ink remains. Prepare fresh ink.					
	Printing is not possible. Displayed when ink is depleted or an ink error has occurred. "Ink error"(P. 165)					

[FUNCTION] key

This section describes the functions and roles assigned to the [FUNCTION] key.

Icon	Overview
	Displays the various menu screens.  "Setup"(P. 103)
	Displays maintenance functions such as test printing and cleaning.
	Switches from LOCAL mode to REMOTE mode.
	Displays adjustment functions such as feed adjustment and drop position adjustment.
	Displays the Heater Temperature Setup screen.
	Clears received data.
	Used to switch from REMOTE mode to LOCAL mode
	Used to move to the previous menu screen
	Used to move to the next menu screen
	Used to close the confirmation screen in response to prompts or other messages
	Used to disable functions
	Indicates that the function is assigned. Displays settings and functions.
	Used to enable or disable multiple items

Displaying Machine Information (Local Guidance)

Press the [ENTER] key on the LOCAL mode screen to display the following information.

- Ink information: Displays ink type, remaining ink levels, and ink errors.
- Information: Displays information such as media width, head height, product serial number, firmware version, command version, and LAN connection status.

1.2 Connecting the Power

The machine must not be installed by the customer. Ask a licensed electrician.

⚠ WARNING



- Always connect the machine to a switchboard with grounded polarity. Otherwise there is a risk of failure, electric shock, or fire. All electrical work (Class C grounding work; formerly Type 3 grounding work) must be handled by a licensed electrician.



- Make sure the connections are correct. Incorrect connections may result in damage to the equipment.
- Be careful to avoid problems in wiring configuration. Disregarding this precaution may result in fire or electric shock.

● Wiring method



- Power sockets are located on the side of the machine. The power plugs that fit these power sockets are included as accessories. The user is responsible for providing power cables when not using the power cables provided. The following electrical work to connect the switchboard and the sockets must be performed by a licensed electrician.
- Use the following types of cables, circuit breakers, and plugs:
 - (1) Cable: VCT-5.5 mm² × 3-core (600 V) or UL-AWG10 × 3C (600 V) or equivalent. Outer sheath external diameter 16 to 20 mm.
 - (2) Circuit breaker: Single-phase 200 to 240 V AC, 20 A
 - (3) Included plugs: IEC60309 standard plugs (Straight-insertion type B)

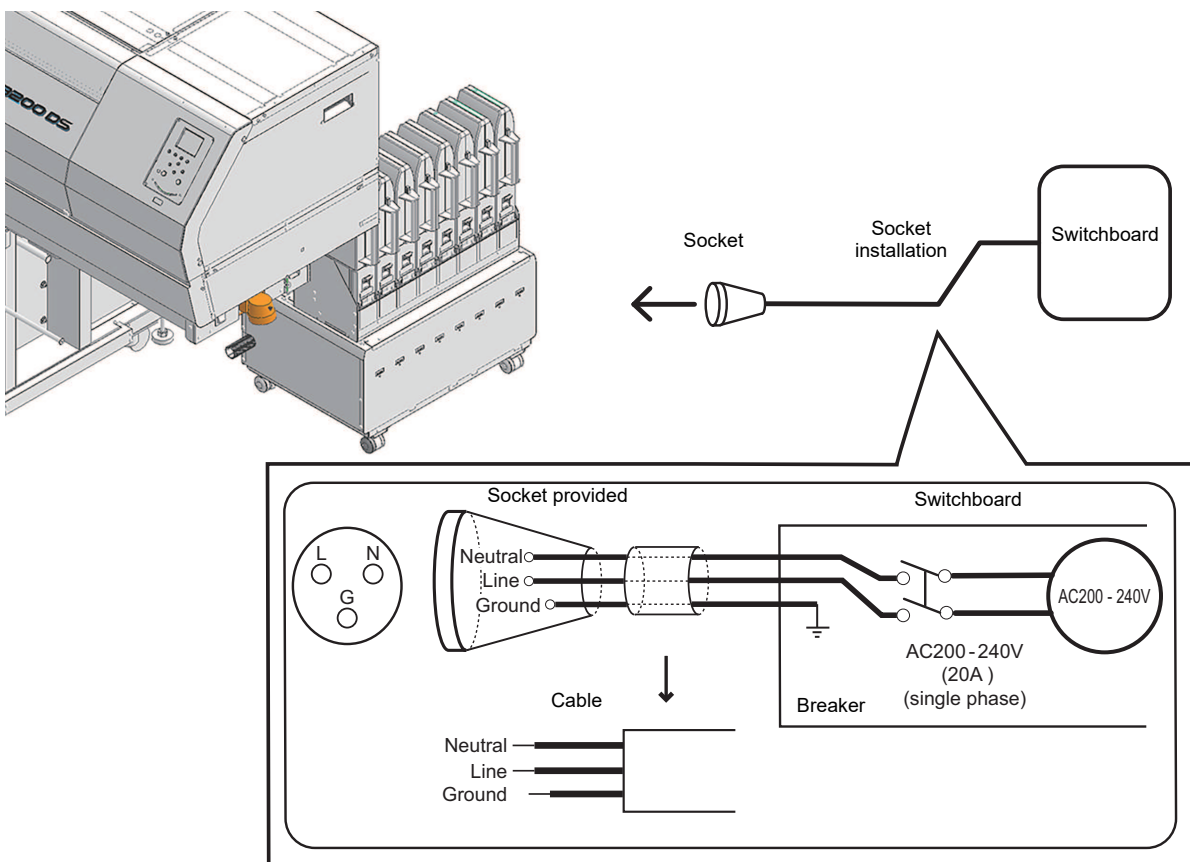

Turning On the Power

- 1** Check to confirm that the main power supply is turned on.
 - If the main power supply switch is not turned on, set to "I".

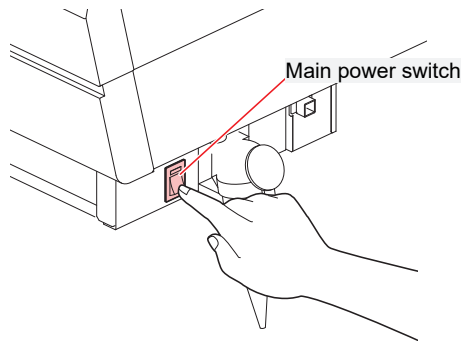

- 2** Press the [END/POWER] key to turn on power.
 - The firmware version appears on the display, and the initial operation is executed. The machine will then enter the Media Select mode, and is ready for use.

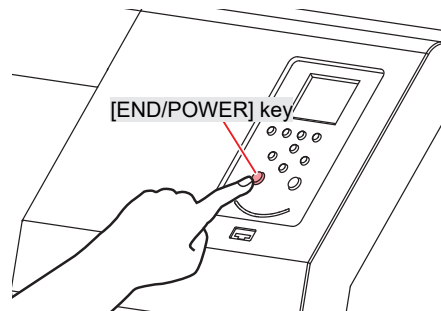

- 3** Turn on the power for the connected PC.



- Close the front cover and maintenance covers. Leaving any of the covers open will disable the automatic maintenance function (including nozzle clogging prevention function and waste ink draining channel cleaning function). This will increase the risk of failure or ejection failures (e.g., nozzle clogging or deflection).

Turning Off the Power



- Check the following when turning off power:
 - (1) The front cover and maintenance covers are closed.
 - Leaving any of the covers open will disable the automatic maintenance function (including nozzle clogging prevention function and waste ink draining channel cleaning function).
 - (2) The carriage has returned to the capping station.
 - If not, the print head nozzle may dry out, resulting in ejection failures (such as nozzle clogging or deflection).
 - (3) Data is not being received
 - (4) No errors have occurred.
 -  ["Problems Causing Messages to Appear"\(P. 164\)](#)

1 Turn off the power to the PC connected.

2 Hold down the [END/ POWER] key.

- A power off confirmation screen appears. Press the [ENTER] key to turn the power off.

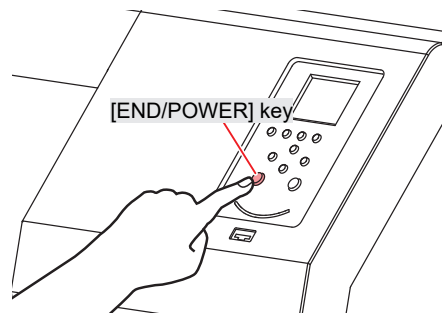

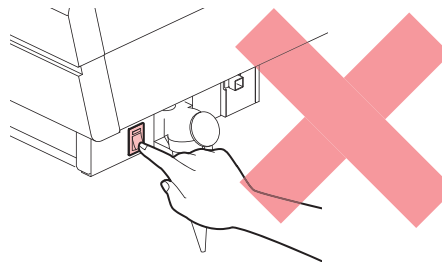

- Do not turn off the main power supply. Turning off the main power supply will disable the automatic maintenance function (including nozzle clogging prevention function and ink discharge channel cleaning function). This increases the risk of ejection failures (such as nozzle clogging or deflection).



1.3 Connecting a PC to the Product

Connect the machine to the RIP PC. The following cables can be used:

1.  ["Using a LAN Cable"\(P. 36\) \(Recommended\)](#)
2.  ["Using a USB Cable"\(P. 37\)](#)

Important! When using the USB cable

- Data may be transferred to the machine too slowly, **causing the carriage to pause at the left-hand or right-hand end** during printing.

Using a LAN Cable

Connect a PC to this product using a LAN cable. Insert a LAN cable until it engages with a click.



- Do not unplug the cable while data is being transferred.

● Network Connection Precautions

Make sure the network is set up as follows: Printing is not possible if the network is not set up correctly.

- Use a Category 6 or higher LAN cable.
- The PC used to transfer print data must be located on the same network as this product. This product cannot be connected via a router.
- Use a 1000BASE-T compatible computer or switching hub. Printing requires 1000BASE-T support.

● Checking the LAN connection

1 Check the display on this product.

- Local guidance can be used for checking.  ["Displaying Machine Information \(Local Guidance\)"\(P. 32\)](#) Printing is not possible if "100Mbps", "10Mbps", or "No Connect" is displayed.

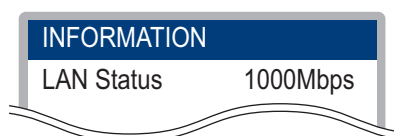

2 Check the lamp on the LAN connector.

- The LAN connector lamp illuminates when the machine is running.

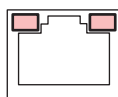

Color	Status	Overview
Green	Illuminated	Connected via 1000BASE-T
	Off	Connected via a network other than 1000BASE-T <ul style="list-style-type: none"> • 1,000 Mbps is not supported if only the orange lamp is illuminated or flashing. Check the specifications for the PC, peripheral devices, and cable.
Orange	Illuminated	Linked up (connected).
	Flashing	Data being received
	Off	Link down (not connected)

Using a USB Cable

Connect a PC to this product using a USB interface cable.



- Do not unplug the cable while data is being transferred.



- Use RIP software that supports the USB interface.



- If the computer has no USB port, contact your local dealer or our service office.



When using the USB cable

- Data may be transferred to the machine too slowly, **causing the carriage to pause at the left-hand or right-hand end** during printing.

● USB Connection Precautions

- When connecting more than one TS330-3200DS to a PC
 - If the PC has more than one USB port, try connecting to a different USB port to check whether the product is correctly recognized. If the product is still unrecognized even when connected to a different USB port, use a commercially-available USB active repeater cable.
- When extending the USB cable
 - Use a commercially-available USB active repeater cable. However, make sure that the combined length of the USB cable and the USB active repeater cable does not exceed 20 m.
 - If the USB cable is extended, this may reduce the data transfer speed to the machine, causing the carriage to pause at the left-hand or right-hand end during printing.
- USB high-speed mode peripheral devices
 - It may not be possible to recognize USB peripheral devices if USB high-speed mode peripheral devices (e.g., USB memory, USB HDD devices) are connected to the PC to which the product is connected. If external USB hard disk drives or other similar devices are connected, this may reduce the data transfer speed to the machine, causing the carriage to pause at the left-hand or right-hand end during printing.
- Unplugging USB memory devices
 - When unplugging USB memory devices from the PC to which this product is connected, use "Stop" in "Safely removing hardware" before unplugging. Otherwise, an [ERROR 201 Command Error] will occur.

1.4 System Configuration

Use RIP software to request to print data created using applications like Illustrator or Photoshop.

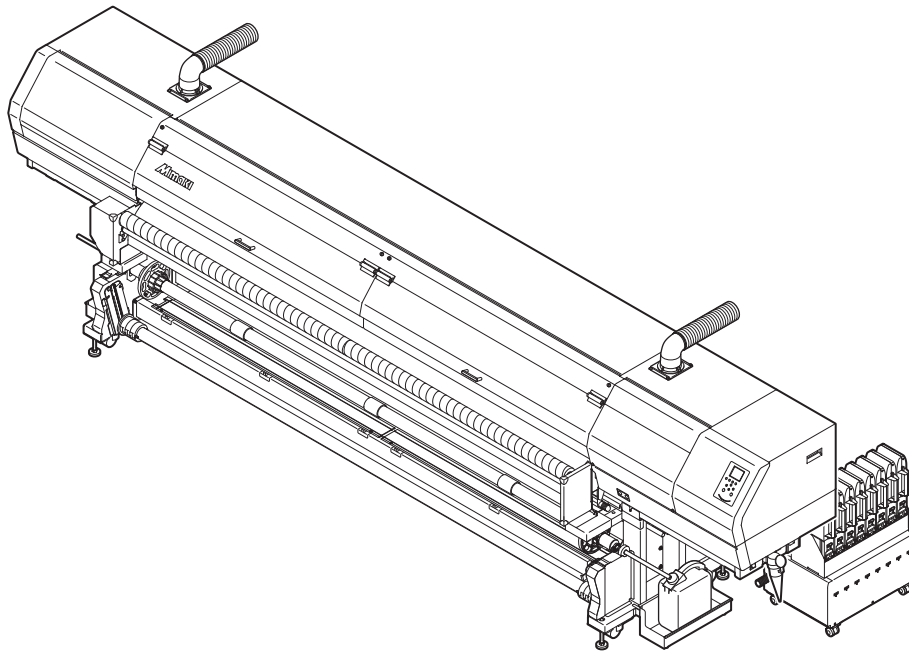
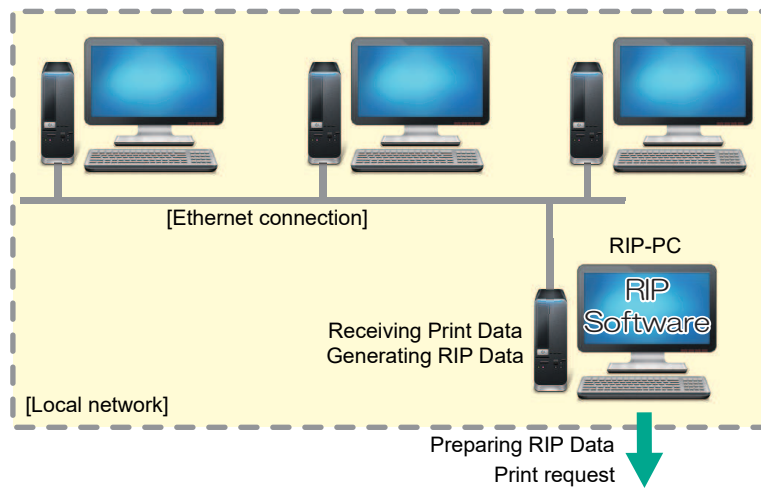

Installing the Mimaki Driver

1 Download the Mimaki driver from our website.

- <https://mimaki.com/download/inkjet.html>
[TS330-3200DS] > [Driver/Utility]

2 Install the MIMAKI driver.

Installing RIP Software

The explanation here applies to MIMAKI RIP software (RasterLink).

- Important!** • If using TxLink, refer to the TxLink operating manual.

1 Install RasterLink.

- The following icon appears on the PC desktop once the software has been installed.



- For more information, refer to the RasterLink installation guide. <https://mimaki.com/download/software.html>



- Once installed, activate the license for Rasterlink. Otherwise, "Profile Update" will not start.

Obtaining Color Profiles

Print quality (e.g., tone, bleeding) will vary depending on the media and ink set. To maintain consistent print quality, select a color profile that suits the media and ink set.

- The RasterLink Series includes a function allowing color profiles to be downloaded and installed directly from the Internet. For more information, refer to "Installing Profiles" in the RasterLink Series installation guide.
<https://mimaki.com/download/software.html>
[RasterLink Series used] > [Manuals]
- Color profiles for Mimaki RIP software (RasterLink) are available on the Mimaki website.
<https://mimaki.com/download/inkjet.html>
[TS330-3200DS] > [Profile]

Setting Up RIP Software

The explanation here applies to MIMAKI RIP software (RasterLink).

- Important!** • If using TxLink, refer to the TxLink operating manual.

1 Launch RasterLink.

- The [Printer Management] screen appears.
- To add a new model, launch RasterLink, then select [Environment] > [Printer Management].

2 Register TS330-3200DS.

(1) Click [Add].

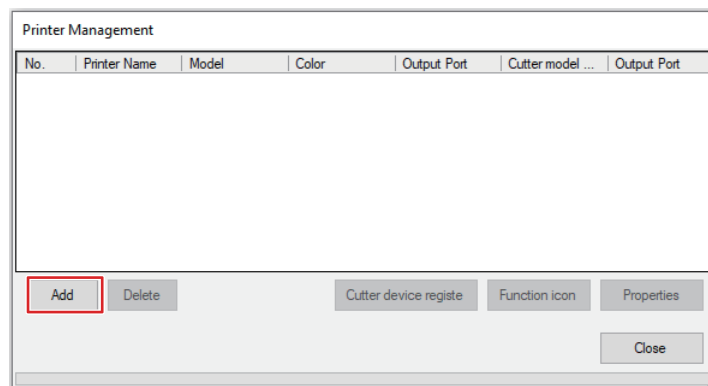

(2) Set the specifics for TS330-3200DS.

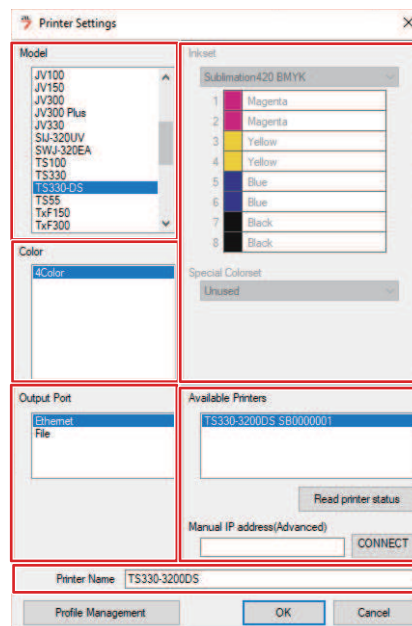

- Model: Select the model.
 - Color: Select the ink set filled.
 - Output Port: Select the cable connected.
 - Available Printers: Select TS330-3200DS connected.
 - Printer: Enter a name as required.
- (3) Click [OK].
- A confirmation screen appears.
- (4) Click [Yes].
- Printer registration starts.



- For more information, refer to the RasterLink installation guide. <https://mimaki.com/download/software.html>

1.5 Ink Replacement Method

When Ink Near End is Displayed

Ink levels are low. We recommend replacing with new ink as soon as possible, because the ink packs are nearly empty. Printing is still possible but continuous printing is not, and some maintenance functions such as cleaning are disabled. Note that ink may run out during printing.

To check which color ink needs to be replaced, press the [ENTER] key on the LOCAL mode screen.  ["Displaying Machine Information \(Local Guidance\)"\(P. 32\)](#)

When Ink End is Displayed

The ink has run out. Replace with new ink.

Thoroughly read the following and make sure you understand its contents.

 ["Notes on Handling Ink or any Other Liquid Used with the Machine"\(P. 13\)](#)



- Pay close attention to ventilation and be sure to wear safety glasses, gloves, and a mask when handling ink, maintenance liquid, waste ink, or other solutions used with the machine. Leaking ink may adhere to the skin or get into the eyes or mouth.

Replacing Ink

Ink replacement procedure

● Removing Ink Eco-cases

- 1 Push down the lever on the pedestal, and remove the ink Eco-case.

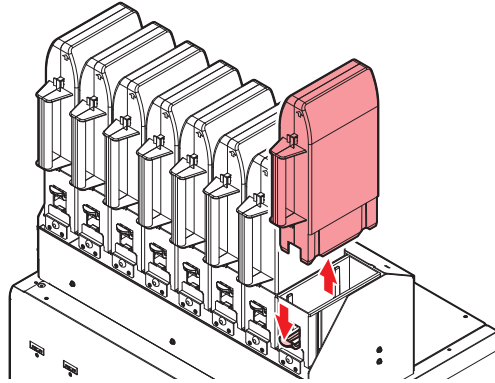

- 2 Open the ink eco-case, then remove the ink pack.

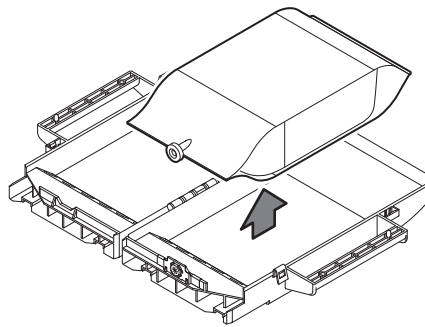

- 3 Remove the ink IC chip.

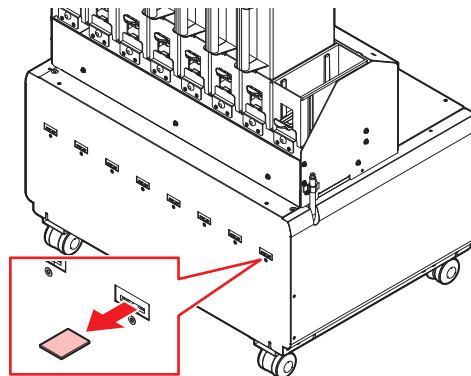

4 Wipe off any ink adhering to the ink eco-case opening.

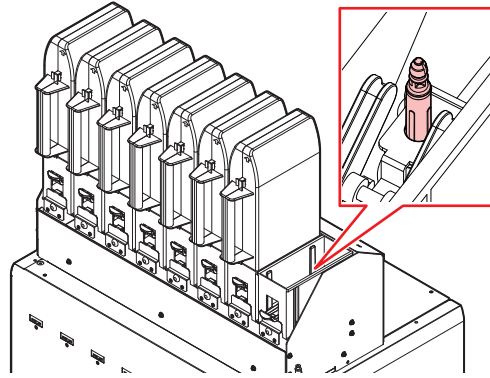

- Check to confirm no foreign matter such as dust or paper towel matter is adhered to the opening. If foreign matter is present, this may block the ink path and lead to leakage.



- We recommend replacing the ink absorber each time you replace the ink pack, to prevent dirt building up on the pedestal of the ink supply unit.

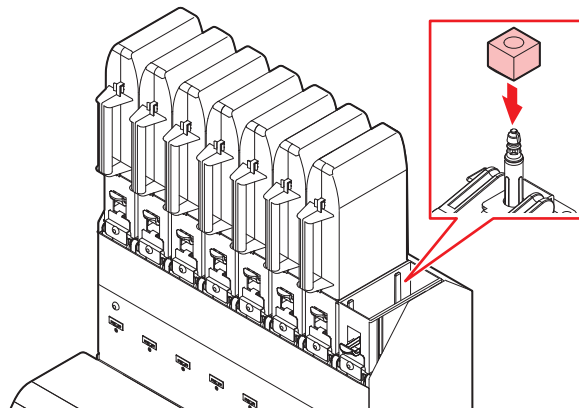

- When disposing of ink, maintenance liquid or other liquid used with the product, or the container or paper towel to which ink or other liquid is attached, contact an industrial waste disposal operator or dispose of the product in accordance with the local laws and regulations.

● Preparing the Ink

1 Pull out the ink pack and ink IC chip from the ink package.

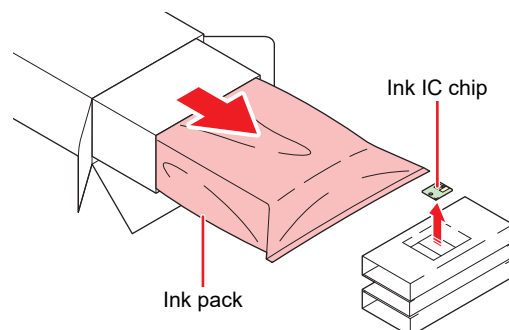

2 Shake the ink pack to the left and right slowly at least 20 times.

- Shake the bottle slowly from left to right to ensure that the ink moves inside, holding the ink pack opening with a paper towel.

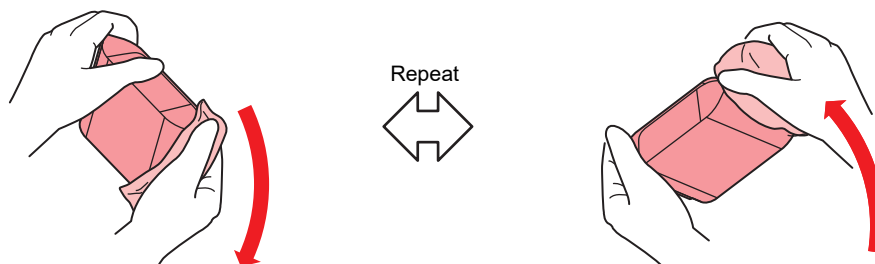

- When using an ink pack with ink remaining, hold a paper towel over the ink eco-case opening and shake slowly with the ink eco-case tilted upright.

3 Remove the seal attached to the ink pack opening.



- Remove the seal completely. If any parts of the seal remain, ink may leak when the ink eco-case is removed from the base.



4 Place the ink pack inside the ink eco-case.

- Push the ink pack connector into the ink eco-case slot. Ink may not be supplied if the connector is out of position.
- Position the pack as indicated on the label on the ink eco-case.

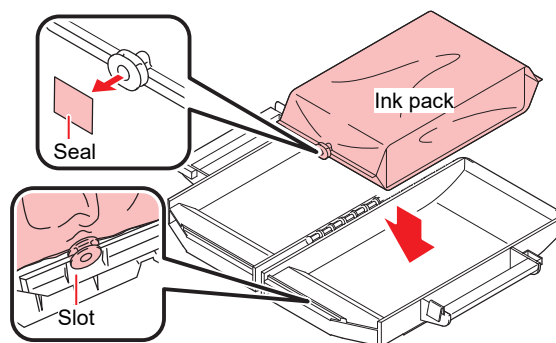

5 Close the ink eco-case gently to avoid pinching the ink pack.



- Be careful to avoid catching your hands or fingers.

● Mounting the ink

The order of the ink eco-cases to be set varies depending on the ink set you are currently using. Check the ink slot numbers, then insert the correct color ink eco-cases.

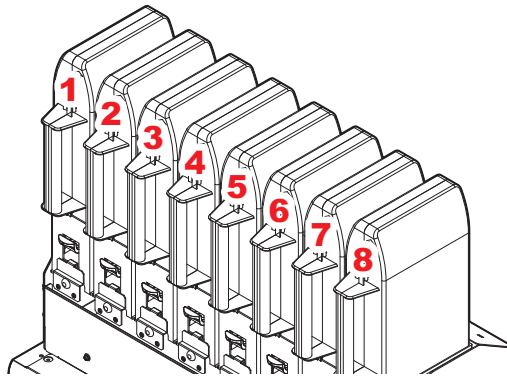

Ink set	Ink positions							
	1	2	3	4	5	6	7	8
4-color (Sb420)	M	M	Y	Y	BL	BL	K	K
4-color (Sb411)	M	M	BL	BL	Y	Y	K	K

1 Set an eco-case on the base.

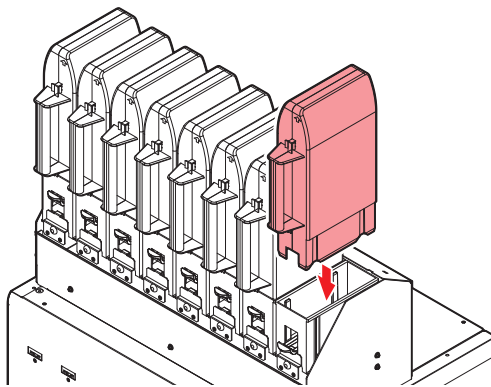

- Fully push in the eco-case. Otherwise, ink may not be fed properly.

2 Insert the new ink IC chip into the ink IC chip slot.

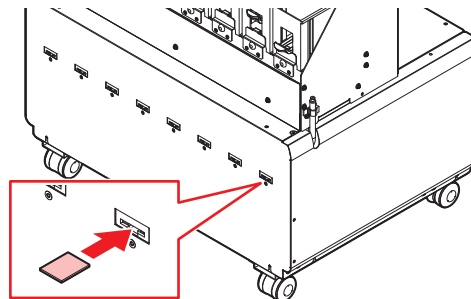

- Insert the ink IC chip with the metal side facing up. Inserting it in the wrong way may cause failure of the machine or damage the ink IC chip.



- Do not touch the metal parts of the ink IC chip. Static electricity may damage the ink IC chip, and dirt or damage may cause the ink IC chip read error.

- **Ink IC chips:** The marking on the ink IC chip indicates the color information.

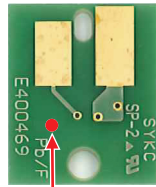

Marking location

Ink Color	Marking
Magenta	● (One red circle)
Yellow	● (One yellow circle)
Black	● (One black circle)
Blue	●● (One blue circle/one red circle)



- Insert the ink IC chip included in the package with the ink. The ink IC chip stores information such as the ink color, remaining amount, and expiration date. Printing is not possible if an incorrect ink IC chip is inserted.

Chapter 2 Printing



This chapter

This chapter describes printing procedures and settings.

Print Process	48	Setting the Heater Temperature	90
Print Preparation Workflow	51	Test Printing	91
Selecting the Platens	52	Changing the Layout Direction for Test Printing	91
Holding the platens	52	Ejection Failures	92
Selecting cloth media platens	53	Head Cleaning	93
Selecting paper media platens	55	Feed Correction	94
Attaching the Ink-Receiving Pan Spacers	58	Feed Correction Procedure	94
Adjusting Print Head Height	60	Correcting the Drop Position	96
Changing the Wiper	61	Drop Position Correction Procedure	96
Preparing the Tension Roller	63	Preparing RIP data	98
Adjusting the torque limiter	63	Printing	100
Attaching the cloth-wound roller	64	Changing the origin	100
Preparing the Take-Up/Feed Tension Bars	67	Starting Printing	101
Loading the Media	68	Stopping Printing (Data Clear)	102
Media	68		
Take-up unit	69		
Feeding unit	72		
Loading the Roll Media	73		
Setting Leaf Media	85		
Registering the Media	88		

2.1 Print Process

1. Select the platens.

 ["Selecting the Platens"\(P. 52\)](#)

2. Attach the ink-receiving pan spacers.

 ["Attaching the Ink-Receiving Pan Spacers"\(P. 58\)](#)



- This is performed when printing on cloth media.

3. Turn on the power.

 ["Turning On the Power"\(P. 34\)](#)

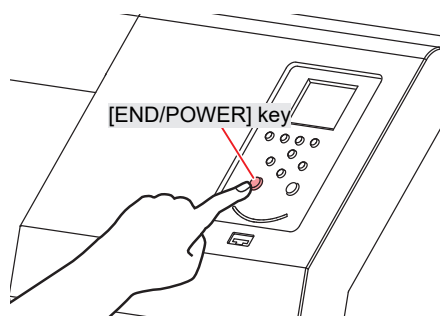

4. Connect a RIP PC to the machine.

 ["Using a USB Cable"\(P. 37\)](#)

 ["Using a LAN Cable"\(P. 36\)](#)

5. Setting Up RIP Software

 ["Installing RIP Software"\(P. 39\)](#) (required first time only)

 ["Obtaining Color Profiles"\(P. 39\)](#)

 ["Setting Up RIP Software"\(P. 39\)](#) (required first time only)

6. Adjusting Print Head Height

Adjust the height adjustment lever to suit the media.  ["Adjusting Print Head Height"\(P. 60\)](#)

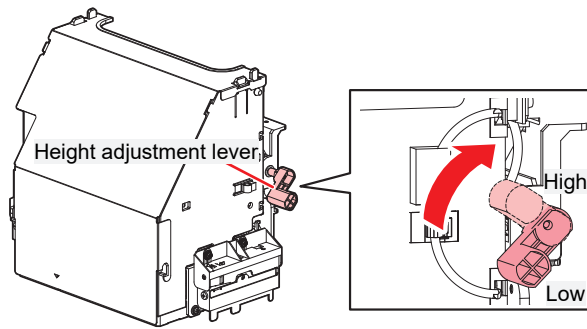

7. Change the wiper.

Change the wiper to suit the print head height.  ["Changing the Wiper"\(P. 61\)](#)

8. Prepare the tension roller.

 ["Preparing the Tension Roller"\(P. 63\)](#)



- This is performed when printing on cloth media.

9. Prepare the take-up/feed tension bars.

 ["Preparing the Take-Up/Feed Tension Bars"\(P. 67\)](#)

10. Load the media.

This machine can be used with roll media and leaf media.  ["Loading the Media"\(P. 68\)](#)

11. Setting the Heater Temperature

 ["Setting the Heater Temperature"\(P. 90\)](#)

12. Check the state of the print head nozzles.

 ["Test Printing"\(P. 91\)](#)

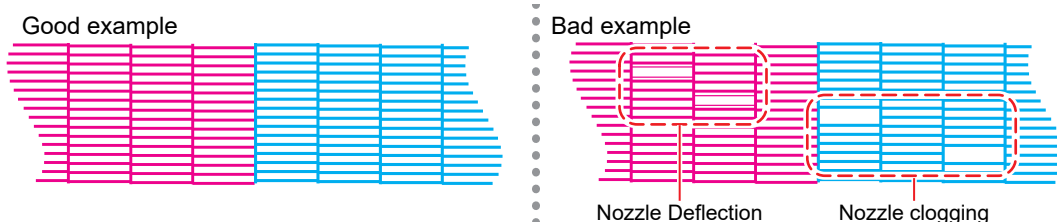

13. Clean the head to clear malfunctioning nozzles.

There are three different head cleaning methods. Choose the head cleaning method based on test print results. ["Head Cleaning"\(P. 93\)](#)

14. Adjust the media feed amount.

["Feed Correction"\(P. 94\)](#)

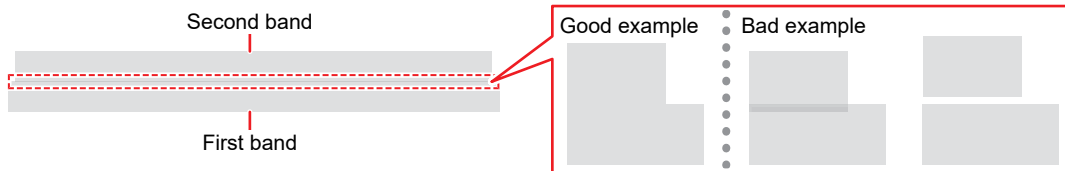

15. Adjust the drop position for bi-directional printing.

["Correcting the Drop Position"\(P. 96\)](#)

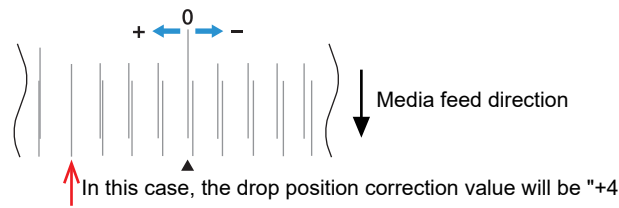

16. Preparing RIP data

["Preparing RIP data"\(P. 98\)](#)

17. Printing RIP data

["Printing"\(P. 100\)](#)

2.2 Print Preparation Workflow

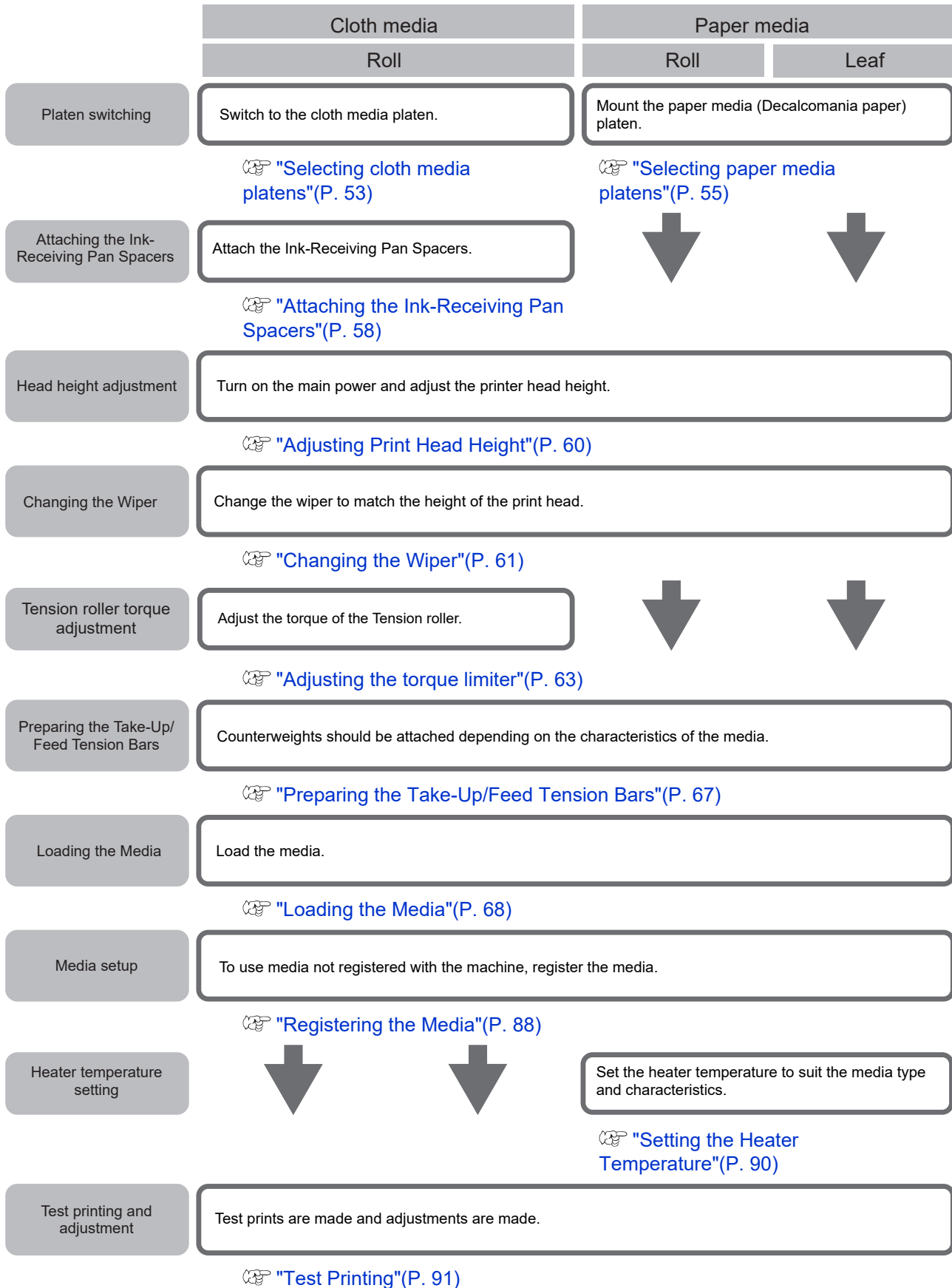

2.3 Selecting the Platens

The TS330-3200DS supports printing on both cloth media and paper media (decalcomania paper). Select the specific platens to suit the media being used.



- Be sure to turn off the main power before switching the platens.
- Be sure to clean the platens before removing if they are dirty.
- Take care to avoid getting ink on your hands or clothes.



- If the media is already loaded, first remove the media before switching the platens.



- When using cloth or decalcomania paper that does not bleed through, select the removable platens for use with paper media. ["Selecting paper media platens"\(P. 55\)](#)

Holding the platens



- The platens consist of thin sheet metal. Wear gloves and take care to avoid cutting your hands.
- Take care not to hit other people or objects when carrying the platens.

Hold the platens with two hands in the center at least 900 mm part.

Hold the platens raised 90 degrees forward from when they are attached flat on the main unit.

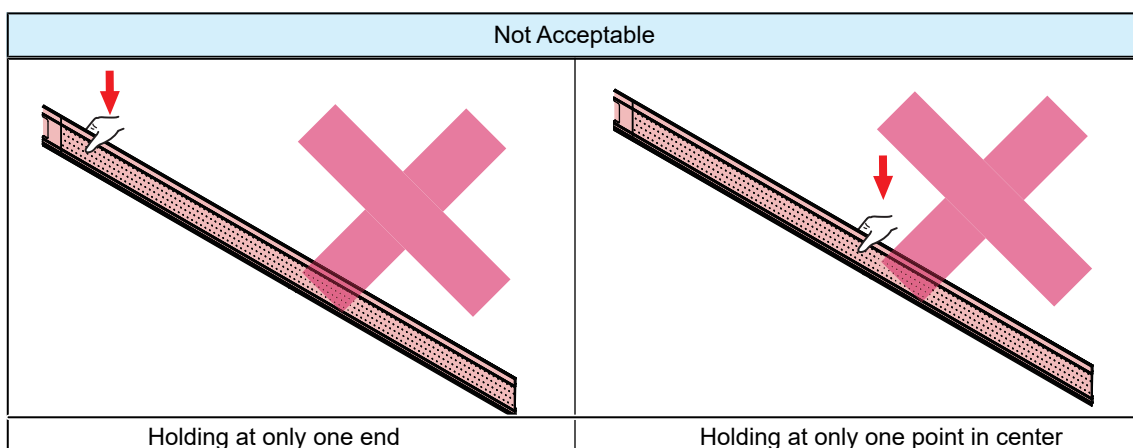
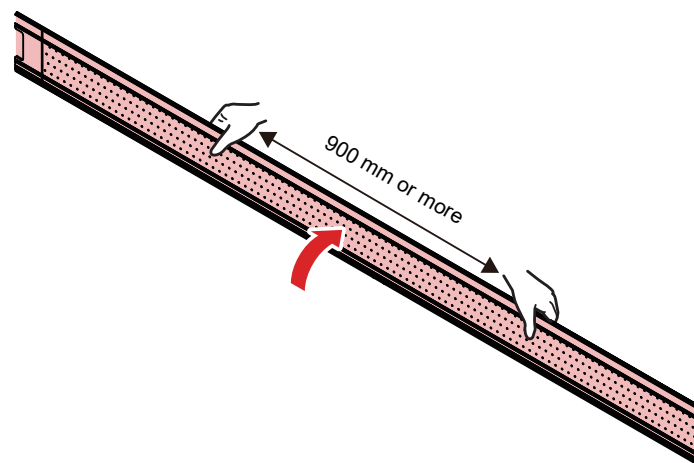

Selecting cloth media platens

If the removable platens are attached, switch to the platens for use with cloth media as follows:

● Procedure

1 Open the front cover.

2 Lift up the removable platens.

- The removable platens are firmly secured with magnets. Lift up as follows:

(1) Insert the two platen removal jigs provided between the main unit and removable platens.

[Platen removal jig insertion positions]

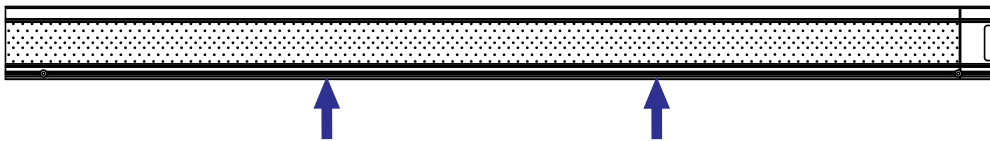

(2) Push up the removable platens, then lift them up.

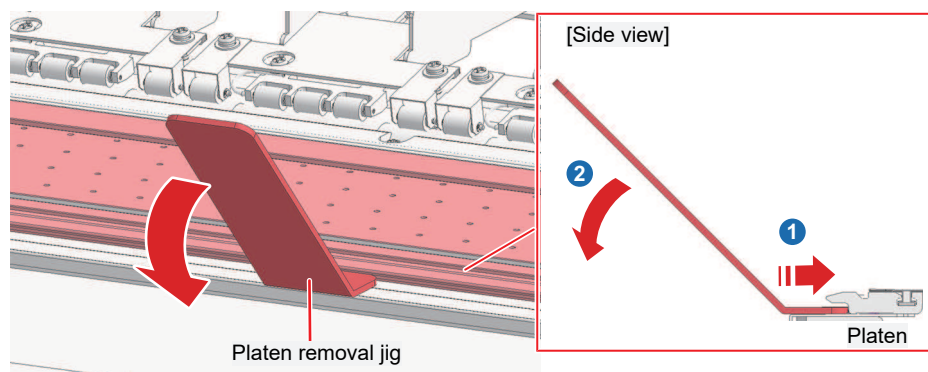

- Take care when lifting the platens, as they are secured with magnets, and may spring up.
- Do not use excessive force when inserting the platen removal jigs. Doing so may damage parts.

3 Pull the raised removable platens forward to detach them from the rear platens.

4 Remove the left and right media holders (one on each side) from the platens.

- Push between the red circled areas and slide the left and right ends to remove.

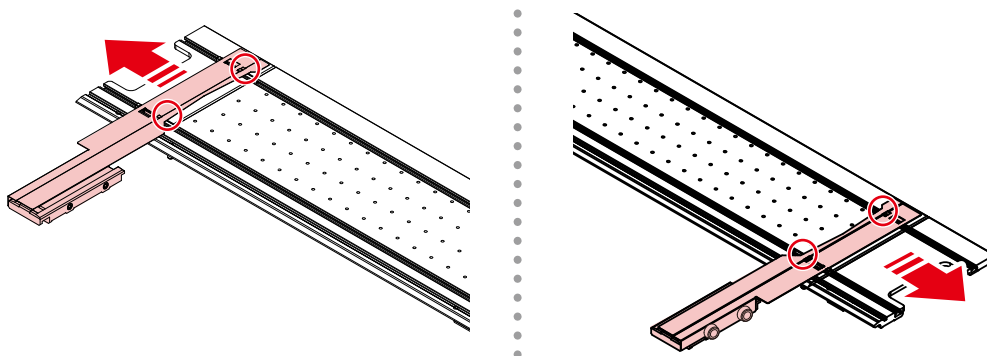

- Do not slide the media holder by holding the part protruding from the platen. The media holder may deform.

5 After removing, store the removable platens in the platen holder underneath.  "Platen holder"(P. 27)  "Holding the platens"(P. 52)



- Do not leave the platen on the platen holder with the media holder in place. Be sure to remove the media holder. When loading media, the media may not be transported correctly due to contact between the media holder and the media.

6 Attach the left and right cloth holders (one on each side).

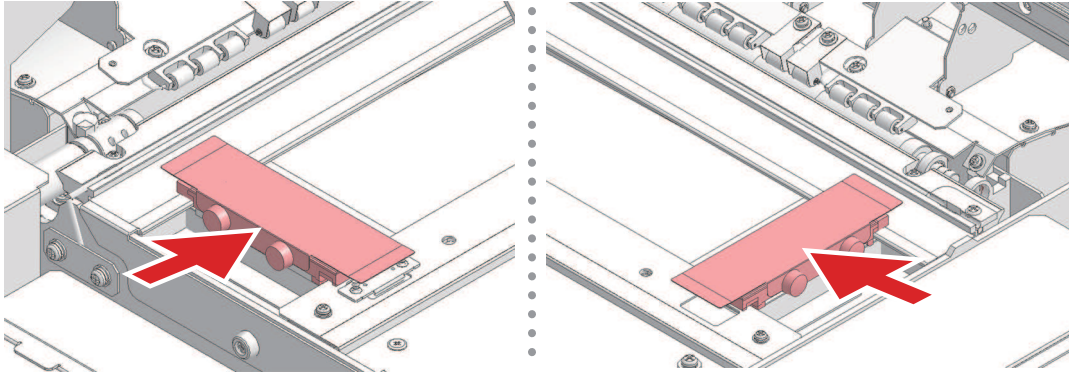

- Attach the cloth holders by first engaging the hook at the rear of the cloth holders on to the rear platen, and then sliding sideways.

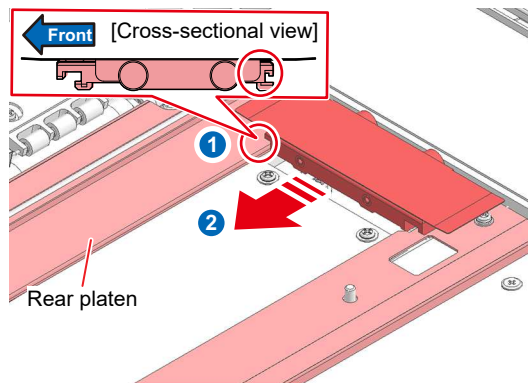

Selecting paper media platens

● Procedure

- 1 Open the front cover.
- 2 Remove the left and right cloth holders (one on each side).
 - Move toward the maintenance space to remove them.
 - Remove the ink-receiving pan spacer, if fitted.

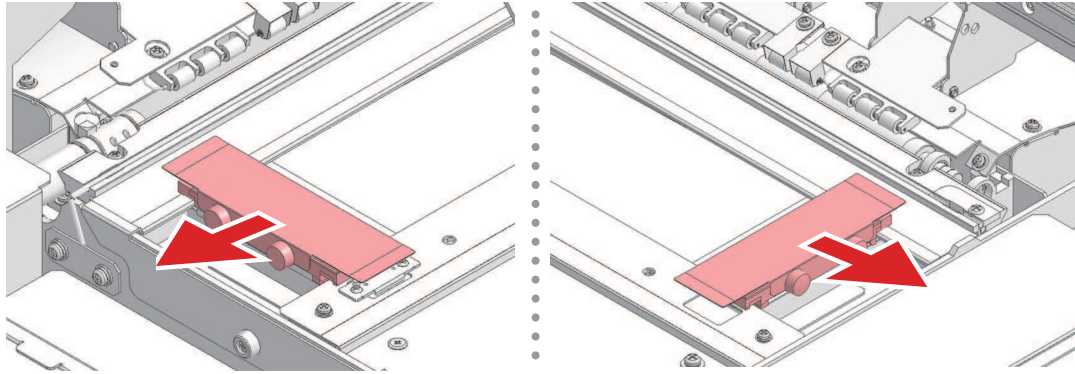

- Remove the cloth holders by moving them to the far edge of the rear platens, then lifting up toward you.

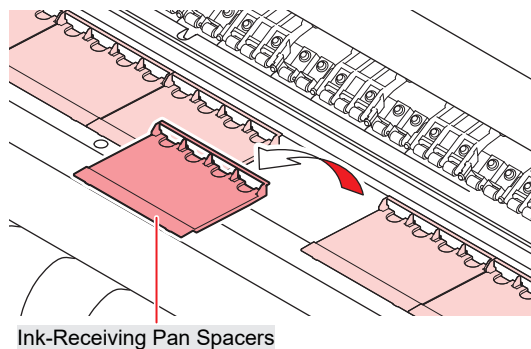
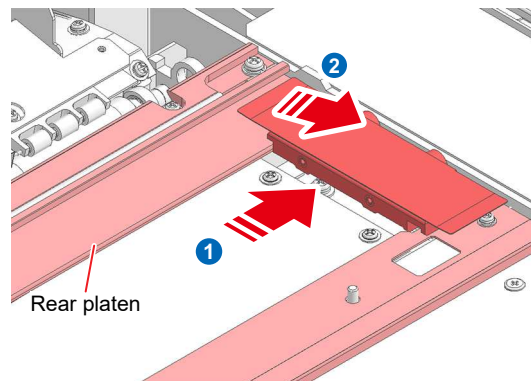

- The Ink-Receiving Pan Spacers is contaminated with ink. When removing it, please wear protective glasses and rubber gloves, and remove it carefully while protecting it with a paper towel or the like.

- 3 Remove the removable platens from the platen holder. ["Platen holder"\(P. 27\)](#) ["Holding the platens"\(P. 52\)](#)

4 Attach the left and right media holders (one on each side) to the removable platen.

- Attach it to the platen by aligning it with the groove, then press and slide it between the red circled areas.

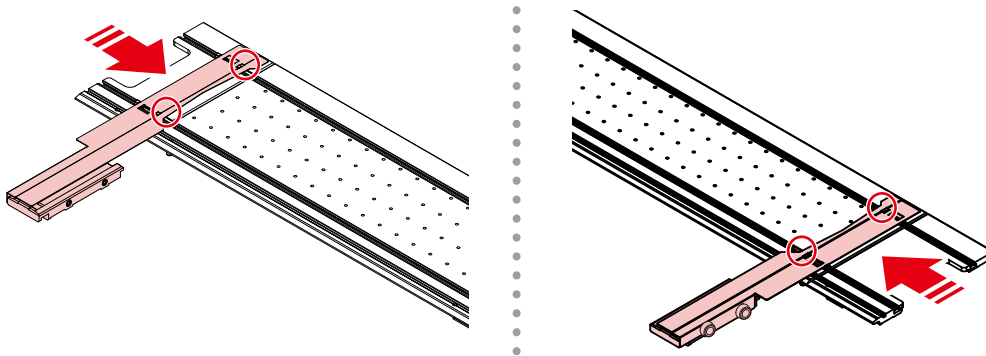

- Do not slide the media holder by holding the part protruding from the platen. The media holder may deform.

5 Push the removable platens L and R up against the rear platen, aligning the edges with the central groove, and securely engage the reference pins in the center into the holes in the ink guard F or platen frame.

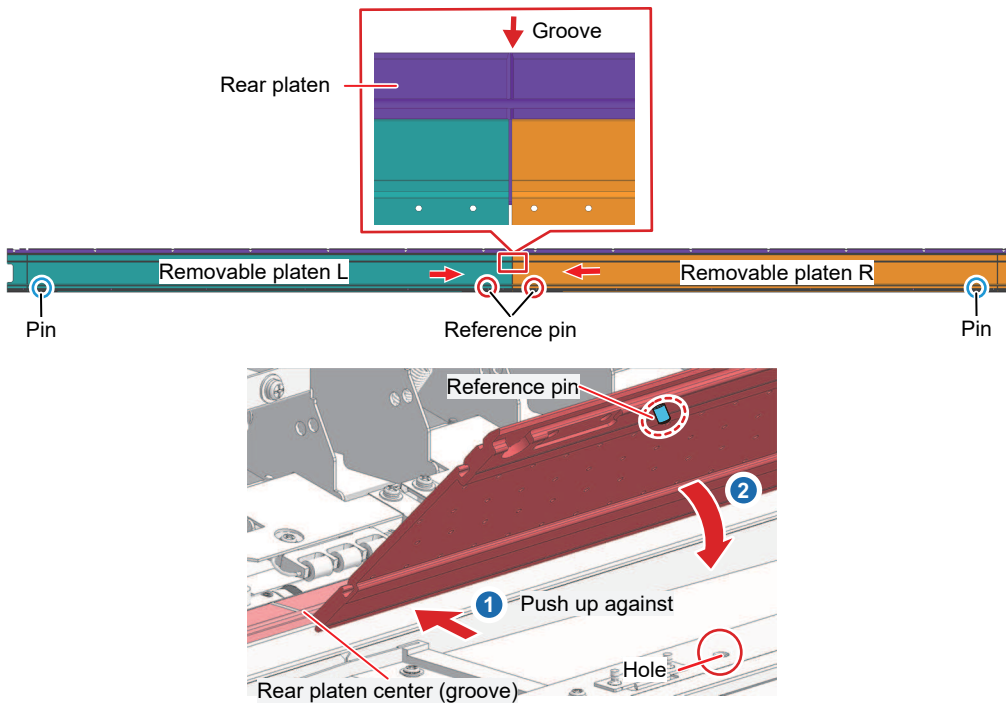

- Take care to ensure that no paper scraps or threads are trapped when pushing the platens up flush.
- Remove any paper scraps or threads before proceeding.



- Check to confirm that the removable platens are securely installed and do not lift up.
- Clean the removable platens after installation if they are dirty. ["Platen and Platen Wire Cleaning"\(P. 130\)](#)



- Take care not to trap your fingers when attaching the removable platens, as the magnets are powerful.
- Attach the platen carefully so that the media holder does not get caught.

- 6** Loosen the media holder height adjuster screws (x2) and tighten the adjuster screws while the media holder is in contact with the platen F cover.

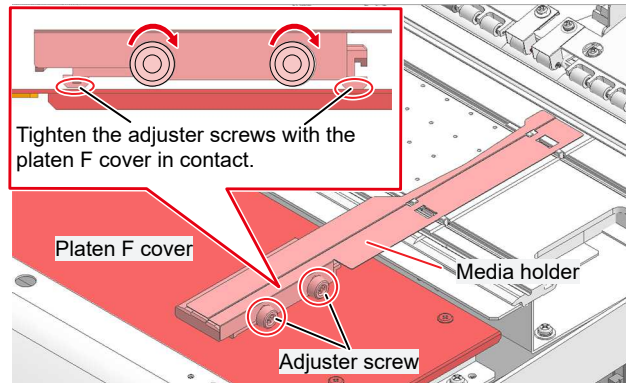

2.4 Attaching the Ink-Receiving Pan Spacers



- This is performed when printing on cloth media.



- Be sure to attach the ink-receiving pan spacers to prevent the media from being made dirty by the ink mist when printing.

● Information about the ink-receiving pan spacers

Two types of spacers are provided with differing widths. The corresponding type should be used to suit factors such as the width of media being printed on.

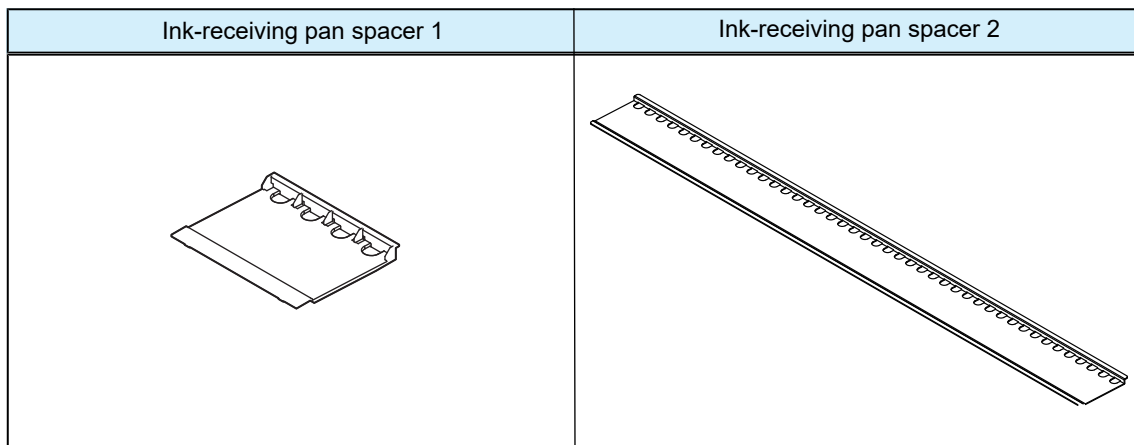

● Ink-receiving pan spacer attachment and removal procedure

- 1 Move the cloth holders to the left and right sides.

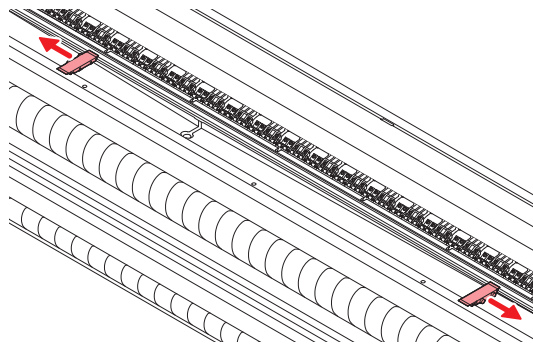

- 2 Attach the ink-receiving pan spacers.

- Select the size and quantity of ink-receiving pan spacers to be attached based on the width of the image to be printed.

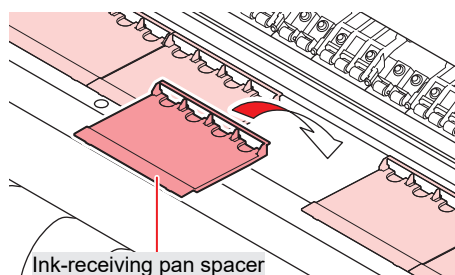



Guidelines for attaching the ink-receiving pan spacers

- The number of ink-receiving pan spacers should be changed to match the media width.
- Place the ink-receiving pan spacer about 20 mm from the left and right ends of the media. If there is a gap, place it so that there is a gap in the center (the gap should be less than 100 mm (less than the width of one sheet of ink-receiving pan spacer 1)).

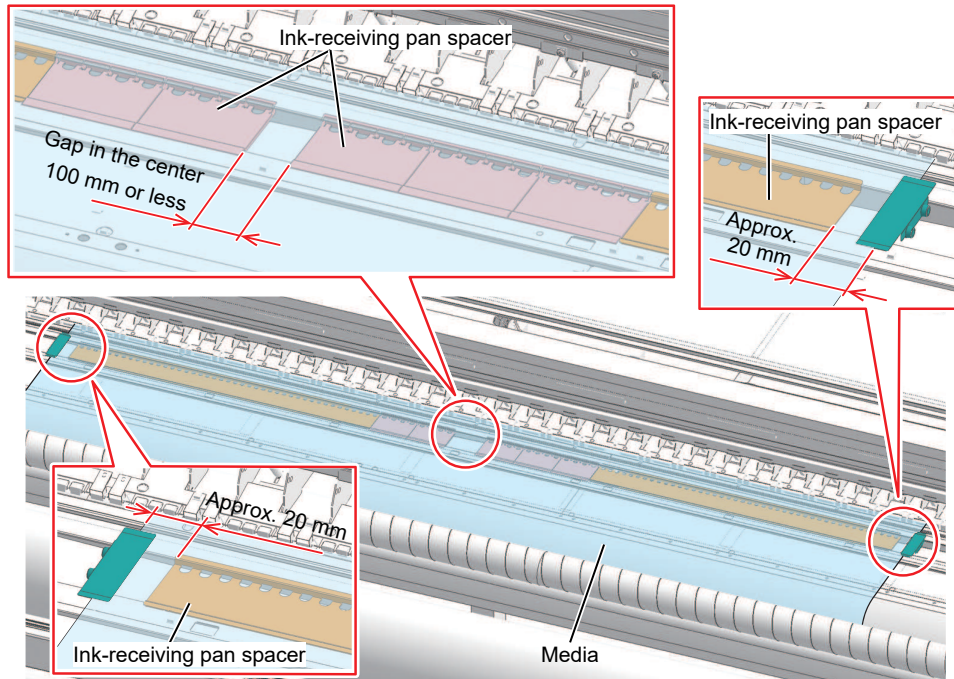

2.5 Adjusting Print Head Height

Adjust the height of the print head according to the thickness of the media you are using.

Range	Gap between print head and platen
Low (recommended)	3.0 mm (default setting)
Middle	3.5 mm
High	4.0 mm



- Be sure to correct the dot position after altering the print head height.  ["Correcting the Drop Position"\(P. 96\)](#)



- With inkjet printers, if the gap between the print head and media increases, the ink droplets tend to vaporize before they reach the media. Vaporized ink may adhere to the print head nozzle surface and media, affecting print quality and causing failure of the print head. Adjust the print head height to suit the media.

1 On the LOCAL mode screen, select [MENU] > [Maintenance], then press the [ENTER] key.

- The Maintenance menu is displayed.

2 Select [Station Maint.] > [Carriage Out] > [Move To Platen Right End], then press the [ENTER] key.

- The carriage moves over the platen.

3 Open the front cover.

4 Use the height adjustment lever to adjust the height.

- Set the height adjustment lever so that the desired height is at the top. If the lever is not set to the correct position, problems such as media jamming and misting may occur, resulting in impaired print quality.

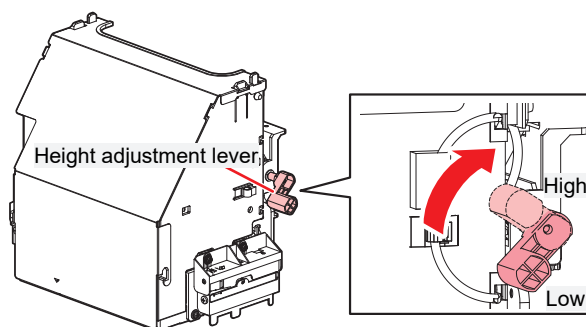

5 Once adjustment is complete, close the cover, then press the [ENTER] key.



- Check the head height indicated on the display. Readjust the height using the height adjustment lever if it is not at the set height.

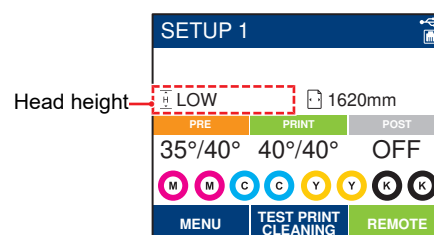

2.6 Changing the Wiper

Change the wiper to suit the print head height. Using the incorrect wiper increases the risk of ejection failures (such as nozzle clogging or deflection) and color mixing.

Range	Wiper type
Low (recommended)	Wiper kit (SPC-0843/Rubber color: Blue)
Middle	
High	HiGap wiper kit (SPC-0850/Rubber color: Black)

- 1** On the LOCAL mode screen, select [MENU] > [Maintenance], then press the [ENTER] key.
 - The Maintenance menu is displayed.
- 2** Select [Station Maint.] > [Carriage Out] > [Move To Platen Right End], then press the [ENTER] key.
 - The carriage moves over the platen.



- Note that the wiper usage count will be reset when the wiper is replaced using [Menu] > [Maintenance] > [Station Maint.] > [Replace Wiper].

- 3** Open the maintenance cover on the right side.
- 4** Remove the wiper.
 - Hold the lug at the rear of the wiper bracket, then pull out the wiper.

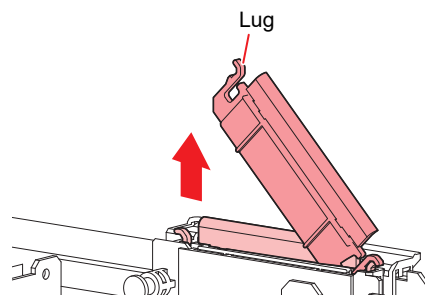

- Clean the wiper slider if it is dirty. 🗨️ ["Wiper Cleaning"\(P. 122\)](#)

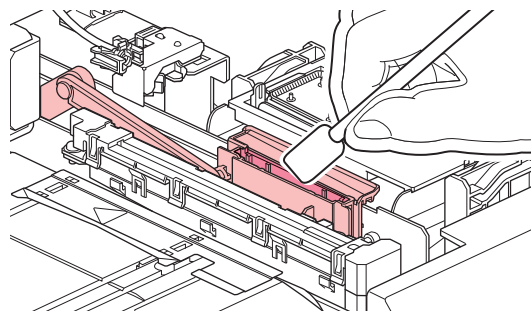

5 Mount a new wiper.

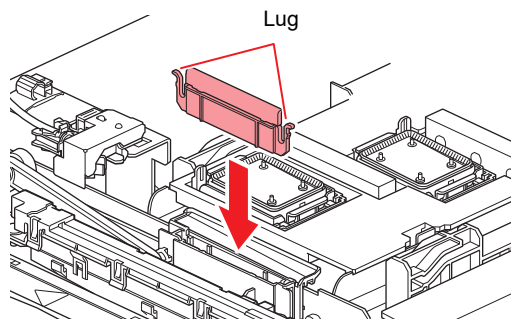

6 Once replacement is complete, close the cover, then press the [ENTER] key.

2.7 Preparing the Tension Roller



- This is performed when printing on cloth media.

Adjusting the torque limiter

The tension roller is fitted with a torque limiter. Turn the torque limiter adjustment nut to adjust the force with which the roller turns.

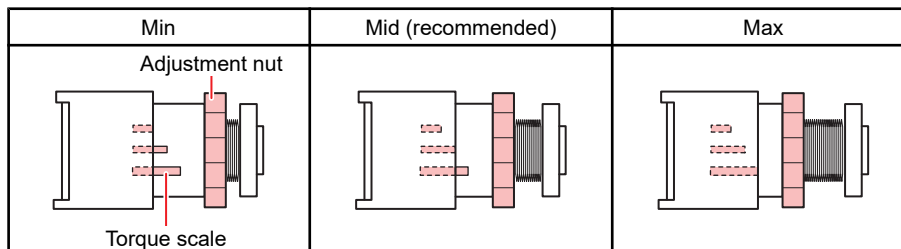
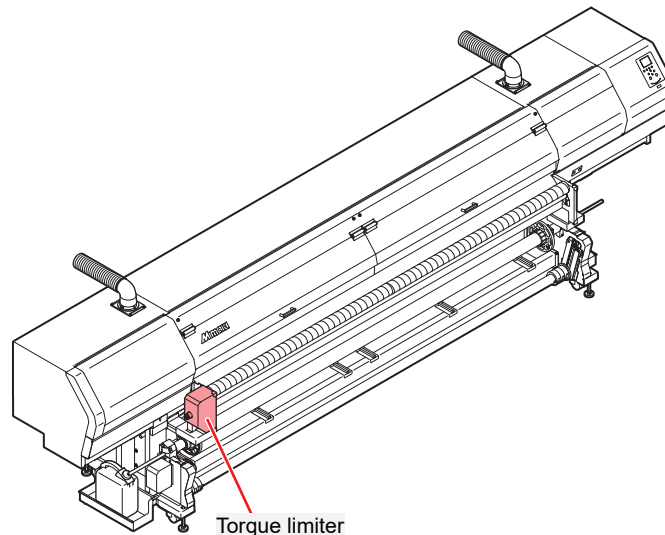

- Clockwise: Increases the tension (thicker media)
- Counterclockwise: Reduces the tension (lighter media)



- If the torque limiter adjustment is too weak, the media will tend to meander and print quality will be reduced.
- If the torque limiter adjustment is too strong, this may cause wrinkling in some media and print quality will be reduced.



If the tension roller spins when the media is loaded

- The torque limiter adjustment is too strong. Either weaken the torque limiter or increase the weight of the tension bar.



- The tension roller torque limiter should be set to "Mid" when printing on cloth media.

Attaching the cloth-wound roller

When printing on to coarse cloth, ink remaining on the back of the cloth may adhere to the tension roller and dirty the cloth media.

Attaching the cloth-wound roller helps to prevent the cloth media from becoming dirty by removing any ink adhering to the tension roller.

Important!

- The cloth-wound roller is not shipped with cloth wound on it. Prepare suitably absorbent cloth that meets the following conditions.
- Adjust the length etc., to suit the cloth used. (Make sure that the cloth-wound roller is in contact with the tension roller at the center and ends.)
 - (1) Material: Cotton jersey, cotton broadcloth, etc.
 - (2) Size: 320 cm × 400 cm (approximate)

1 Remove the cloth-wound roller.

- The cloth-wound roller is located below the tension roller.

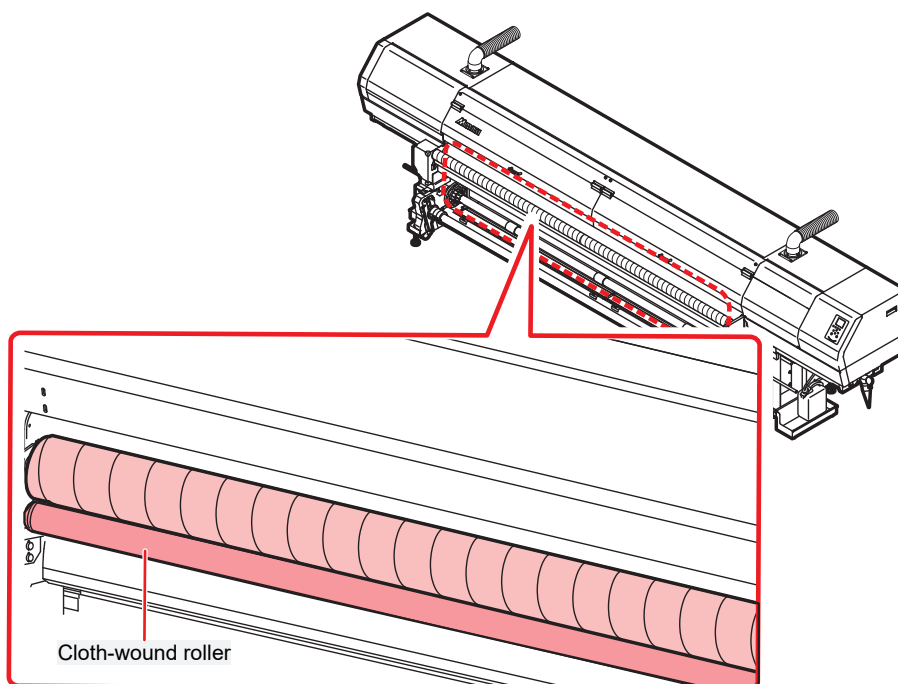

2 Wind cloth around the cloth-wound roller.

(1) Align the cloth with the roller.

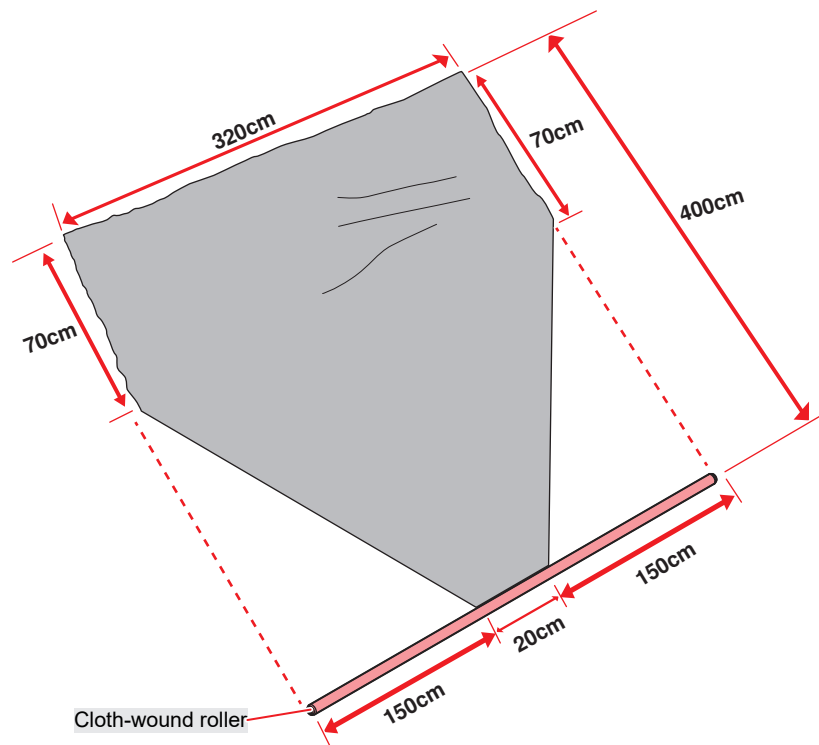

(2) Secure the cloth to the roller with adhesive tape.

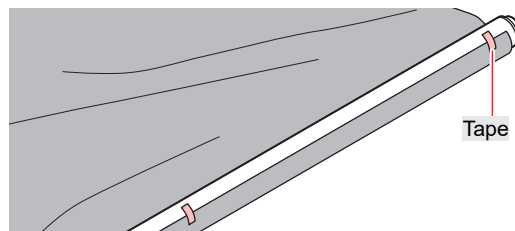

(3) Wind the cloth around the roller, then secure with adhesive tape.

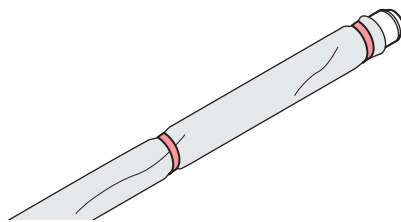

complete drawing



- By wrapping the cloth so that a bulge is created in the center, the entire area of the tension roller can contact the cloth set on the cloth-wound roller.

3 Attach the cloth-wound roller with the cloth wound on it.

- Mount the cloth-wound roller in the groove below the tension roller.
- Adjust the positions of the bearings at both ends of the cloth-wound roller. Loosen the screws on the bearing, then adjust so that the cloth-wound roller makes contact with the tension roller.

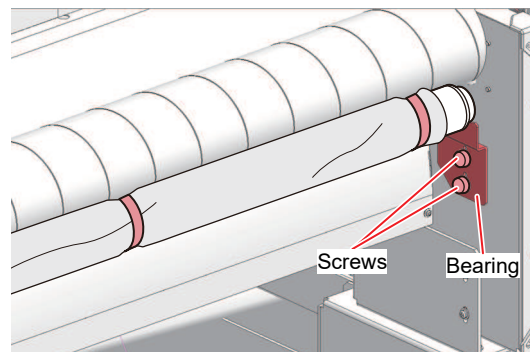

Important!

- Make sure that the tension roller and the cloth wound on the cloth-wound roller make contact in the entire area at both ends and in the center. If contact is not made over the entire area, adjust the size and shape of the cloth wrapped around the cloth-wound roller.

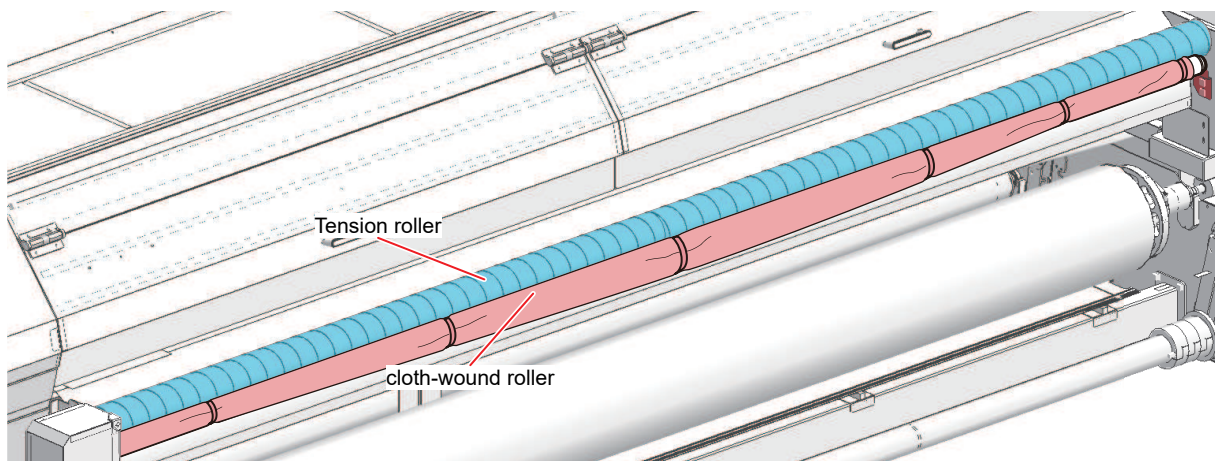

- When setting the cloth on the cloth-wound roller, wrap the cloth around the roller so that it bulges in the center. By doing so, even if the cloth winding roller deflects, the entire area of the tension roller will be in contact with the cloth set on the cloth-wound roller.

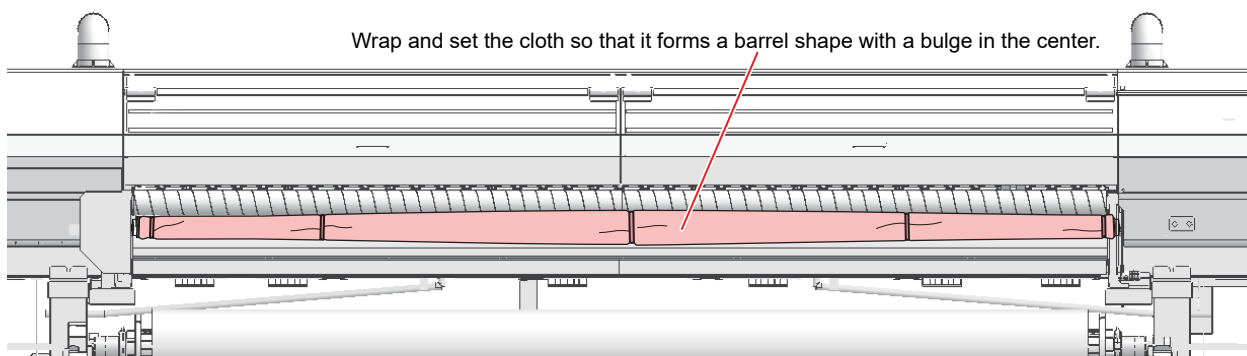

4 Rotate the tension roller by hand to confirm that it turns smoothly.

- If the tension roller does not turn smoothly, check the mounting position of the cloth-wound roller.

2.8 Preparing the Take-Up/Feed Tension Bars

Counterweights should be attached depending on the characteristics of the media.

Up to three sets of counterweights can be attached to the left and right sides of the tension bar respectively.



- 12 counterweights are provided, with each one weighing approximately 500 g (with each set weighing approximately 1 kg when stacked together).
- Take care when handling the counterweights. Injury may result if fingers or feet become accidentally trapped.



- There is no distinction between upper and lower counterweights. They can be mounted either above or below.
- Mount the same number of counterweights on either side.
- Keep the unused counterweights in the storage box to prevent them from becoming misplaced.



- When printing on cloth media, attach three sets of counterweights each (six counterweights each, 6 kg in total) on the left and right ends of the take-up tension bar.

Media state	Action
<ul style="list-style-type: none"> • The print surface is tautly tensioned. • Printing is consistent. • Minimal sagging or wrinkling is seen in the media. 	The media is correctly tensioned. No weight adjustment is required for the tension bar.
<ul style="list-style-type: none"> • Wrinkling occurs in the media feed direction. • The media meanders during printing. 	The media is excessively tensioned. Reduce the counterweights to reduce the weight on the tension bar to suit the media being used.
<ul style="list-style-type: none"> • The media sags and is not taken up smoothly. • The media is lifting up on the platen. 	The media is insufficiently tensioned. Increase the counterweights to increase the weight on the tension bar to suit the media being used.

● Instructions for attaching the counterweights

- 1** Insert a lower counterweight onto the mounting pins.
- 2** Insert an upper counterweight onto the mounting pins so that it engages with the lower counterweight.
- 3** Secure the counterweights using the weight retaining rubber attachments.

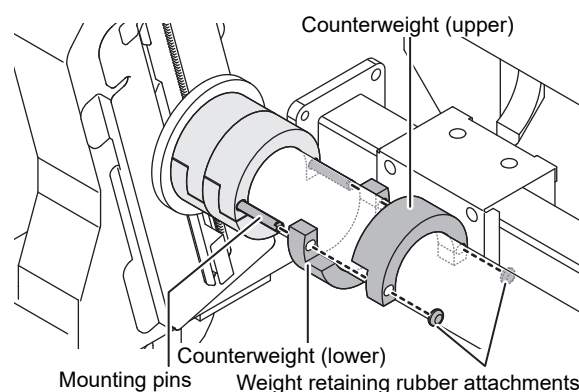

2.9 Loading the Media



- Adjust the head height before loading media. Moving the carriage after the media has been loaded may result in the print head coming into contact with the media and being damaged.

Media

● Media handling precautions



- Use Mimaki-approved media to ensure consistent high-quality printing.

WARNING



- Assign at least two persons to load roll media. (Assign up to six persons to this task depending on the media weight.)
- When loading roll media, be careful to avoid dropping it on your feet. Also be careful to avoid catching your fingers. Disregarding this precaution may result in injury due to the weight of media.

NOTICE



- When using a lifter to load media, prepare a suitable one by checking the specifications.



- Do not leave the media in the machine when not in use. Otherwise dust may accumulate on the media. Do not use media that has been wiped free of dust. Wiping media can generate static electricity, possibly affecting print quality.
- Do not use media immediately after removing it from the package. The media may expand or contract depending on the temperature and humidity of the location in which it was stored. Allow the media to stand for at least 24 hours in the same indoor environment as the machine before loading it.
- Do not use media if it is curled. Curled media may not only damage the print head, but may also affect print quality.



- Avoid storing unopened media in hot or humid places, or in direct sunlight.
- After opening, be careful not to touch the surface (especially the printing surface).

Take-up unit

Use the switch on the take-up unit to change the media take-up direction.

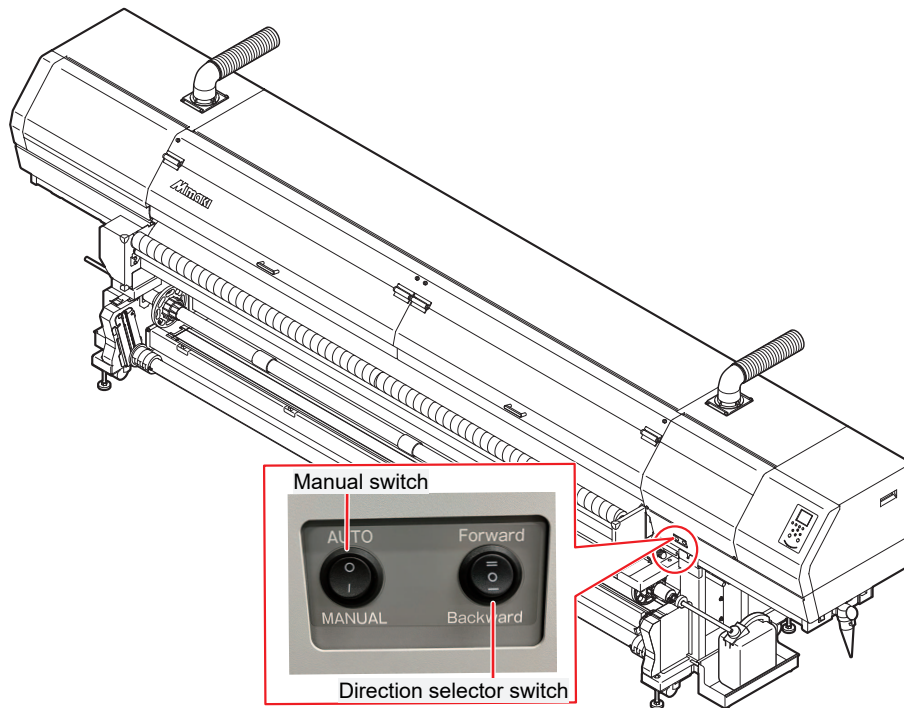

Name	Overview	
Direction selector switch	Forward	To take up media with printed surface on the outside
	OFF	Does not operate
	Backward	To take up media with printed surface on the inside
Manual switch	Selects the take-up method (AUTO or MANUAL).	

Removing the roll media after printing

● Procedure

- 1 Release the lock on the take-up tension bar, then lower the tension bar.

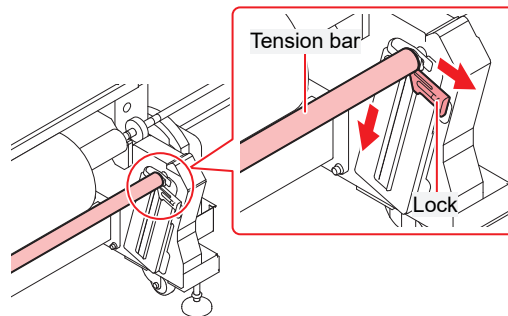

- Support the tension bar with your hand to keep it from dropping suddenly when the lock is released. Lower slowly. Sudden drops may damage the parts.

- 2 Open the left-hand cover on the take-up unit, then pull the take-up shaft out and forward.

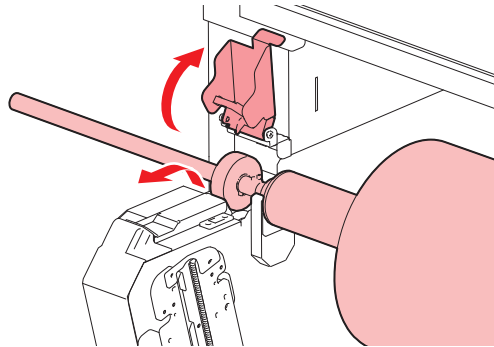

- 3 Pull out until the white plastic collar rests in the groove on the top of the leg.

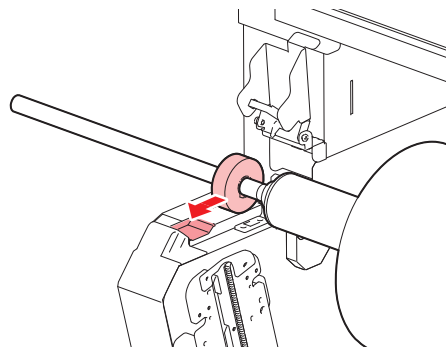

4 Remove the media.

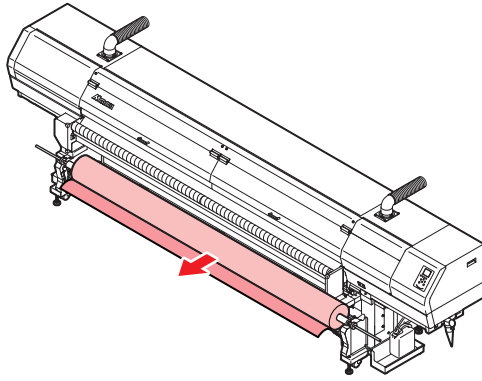

5 Remove the roll holders, then remove the paper core.

- (1) Unlock the clamping lever.
- (2) Pull of the roll holder.

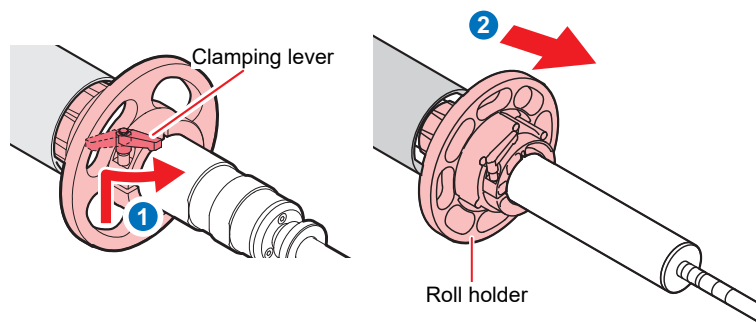

Feeding unit

The switches on the feeding unit can be used to change the media feed direction.

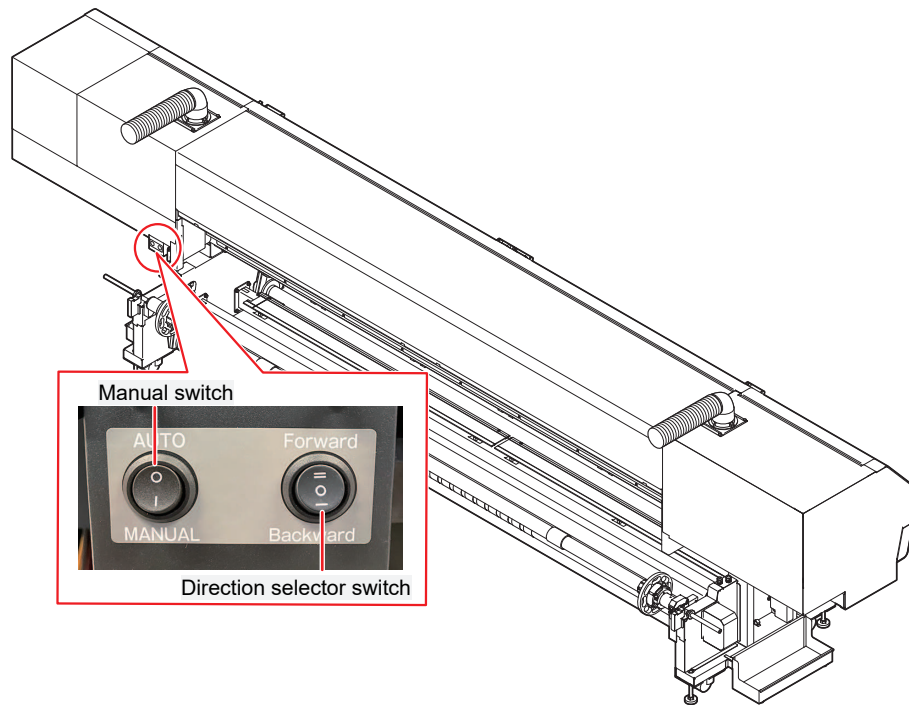

Name	Overview	
Direction selector switch	Forward	To feed the media with the printed surface on the outside
	OFF	Does not operate
	Backward	To feed the media with the printed surface on the inside
Manual switch	Selects the feed method (AUTO or MANUAL).	

Media loading position

Media setting position plates are affixed to the leg stays, one each on the left and right sides. Move the media to the center of the machine so that it aligns with the same values on the position plates on each side, then secure into place.

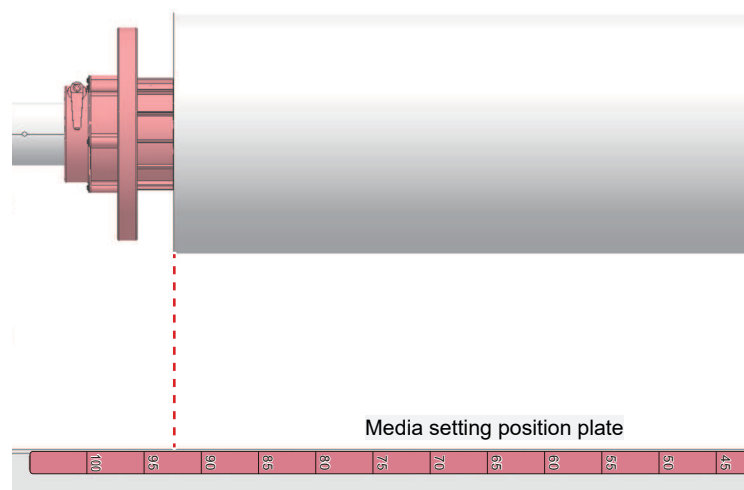

Loading the Roll Media

Load the media on to the feeding unit

- 1 Insert the media mounting shaft inside the media.

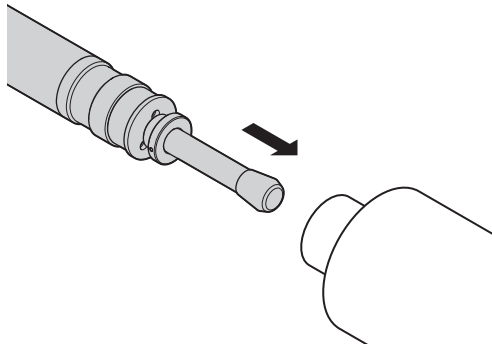

- 2 Mount the two (left and right) roll holders.

- (1) Insert the two (left and right) roll holders into the paper core, then lock in place with the clamping levers.

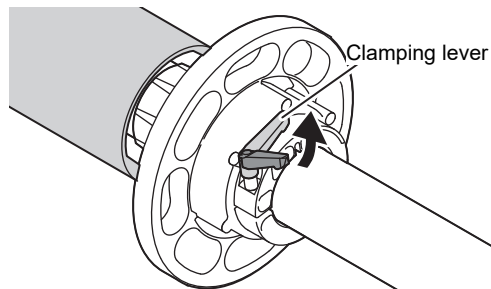

- (2) Rotate the roll holder handles to secure on to the paper core.

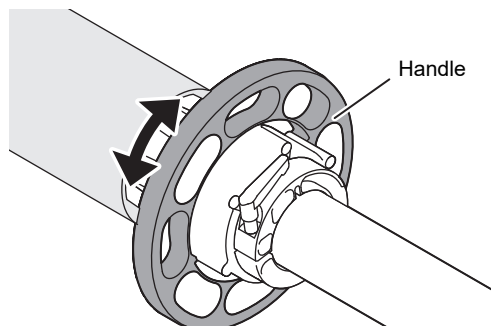

Roll holder clamping range

- Make sure that the handles are clamped within the range indicated on the labels affixed to the roll holders.

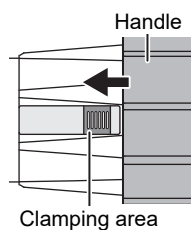

3 Open the AMF covers.

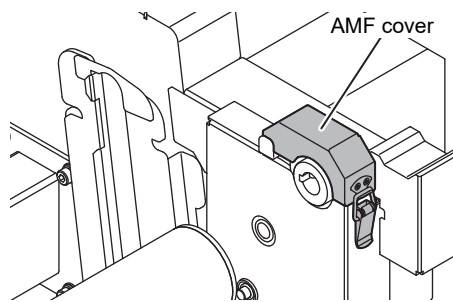

4 Mount the media mounting shafts with the media mounted on the feeding unit, then close the AMF covers.

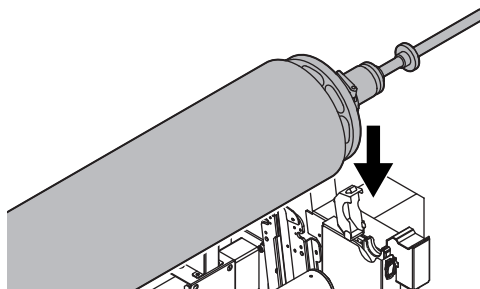

Loading Media on to the Printer Main Unit

- 1 Raise the clamp lever.

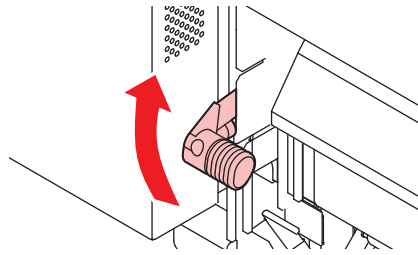

- 2 Select [Feeding&Take-up] for the tension bars used, then press the [ENTER] key.

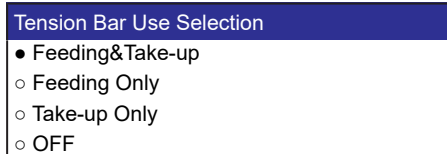

- 3 Raise the feed tension bar to its highest position. Lock into place.

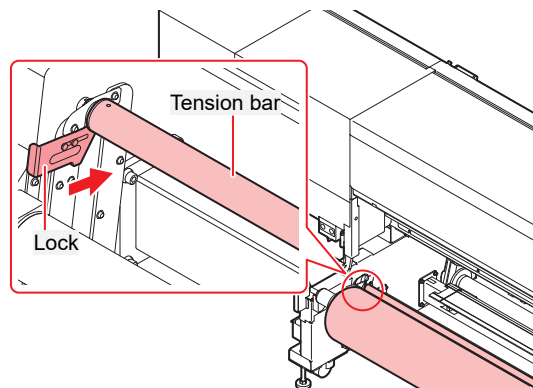

4 Feed the media from the feeding unit through to the printer main unit.

```
Media Loading Check
Load media
to take-up
unit.                COMPLETE
↑/↓ Media Feed      [ENT]
```

- Insert the media through the return shaft and feed tension bar, then between the pinch rollers and the grit rollers.

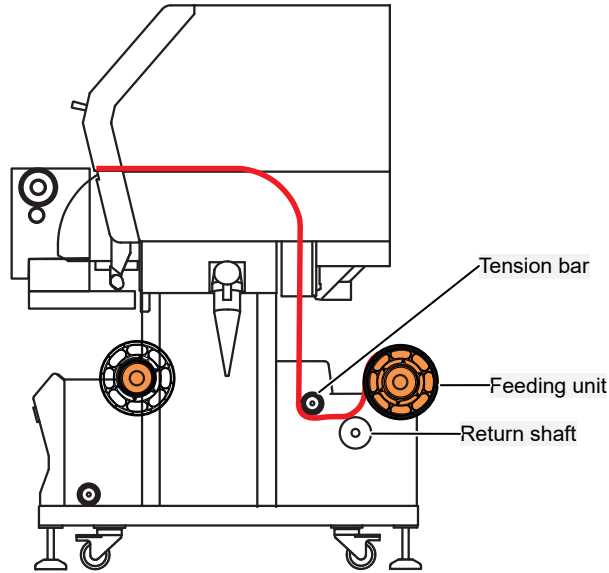



- Be careful when loading the media. Some types of media may catch on the pinch rollers.

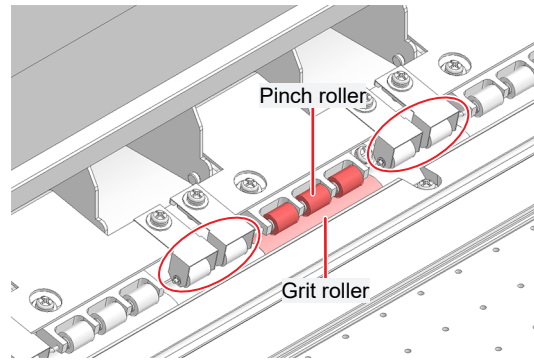

- If the media catches easily even when loading with care, try the following:
 - (1) Cut the media diagonally.

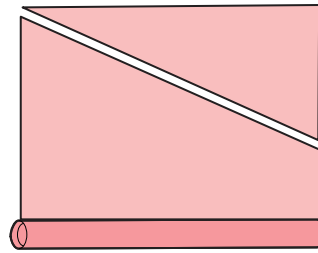

- (2) Feed the media into the grit rollers from the pointed end (circled in blue).

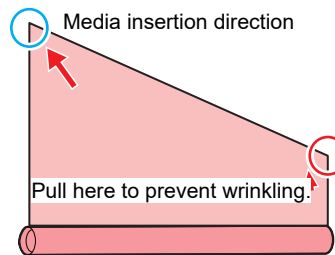

- When feeding the media, pull on the other corner to prevent wrinkling.
- Raising the media above the height of the platen will make it easier to insert and will keep the media from catching on the grit roller protrusions.

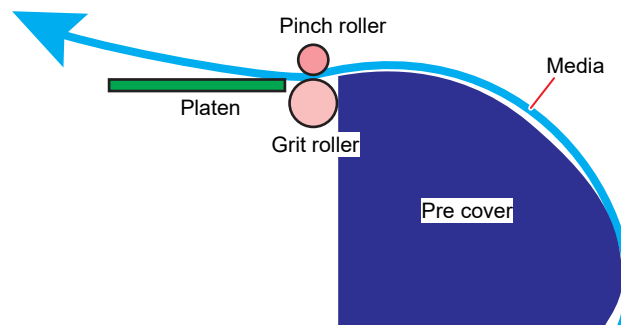

- (3) Cut off the diagonally cut section so that the media is cut straight across.

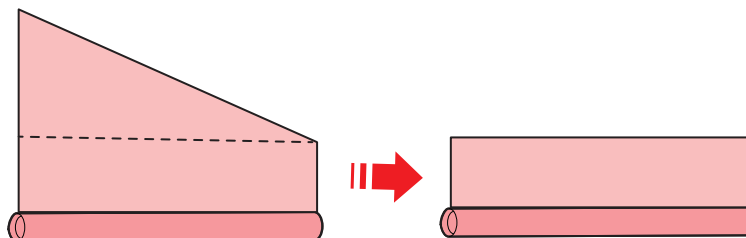

5 Lower the clamp lever.

- Hold the media with the pinch roller and grit rollers.

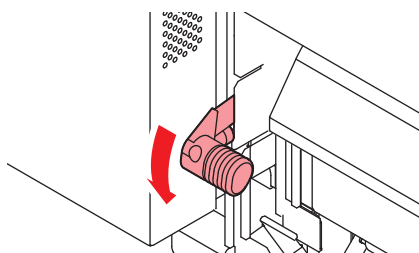

6 Move to the front of the machine and open the front cover.

7 Raise the clamp lever and pull out the media.

- Make sure the media does not fall to the rear.



- Adjust the media position so that it does not cover the right-hand slit line on the platen. Movement at an angle may result in damage to the print head.

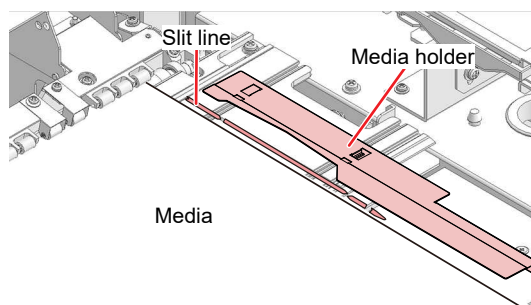

- The areas extending 20 mm from both sides of the media are margins.
- Use [Function Setting] > [WhiteSpace Setting] > [Margin] to change the settings

8 Check how far the media was pulled out.

- Pull the front edge of the media gently at several points to confirm that the media was pulled out by the same amount.

9 Lower the clamp lever.



- Do not pull the media when the clamp lever is lowered (the media is clamped). Doing so may damage the machine.

10 Release the lock on the feed tension bar.

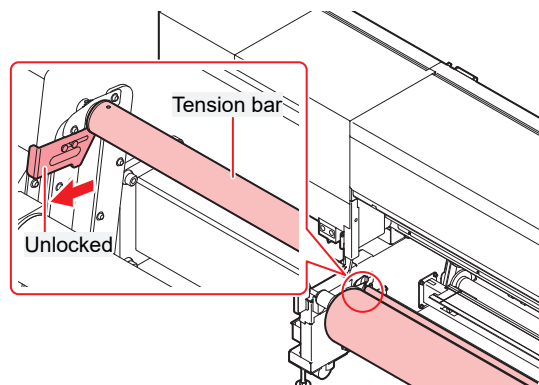



- Support the tension bar with your hand to keep it from dropping suddenly when the lock is released. Lower slowly. Sudden drops may damage the parts.

11 Once the media has been loaded into the feed unit, press the [ENTER] key.

- The feed tension bar origin is reset.

12 Load an empty paper core on the take-up unit.

Media Loading Check	
Load media to take-up unit.	COMPLETE
↑/↓ Media Feed	[ENT]

13 Raise the take-up tension bar to its highest position, then lock in place.

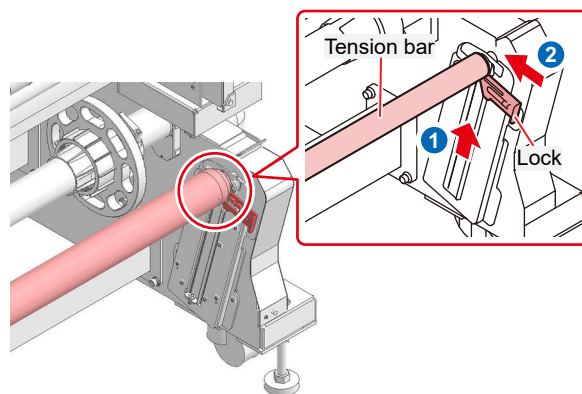

14 Press the key to feed the media until it reaches the paper core on the take-up unit.

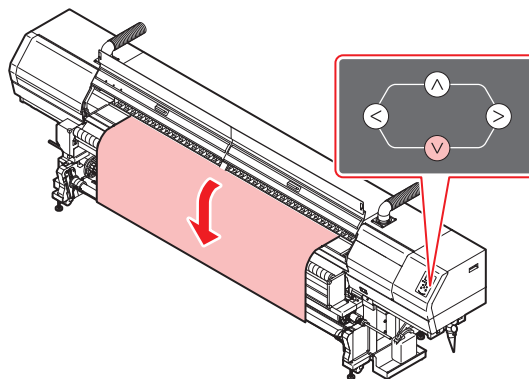

15 Feed the media from the printer main unit through to the take-up unit.

- **For cloth media:**

Pass the media over the tension roller and tension bar, then secure to the take-up unit.

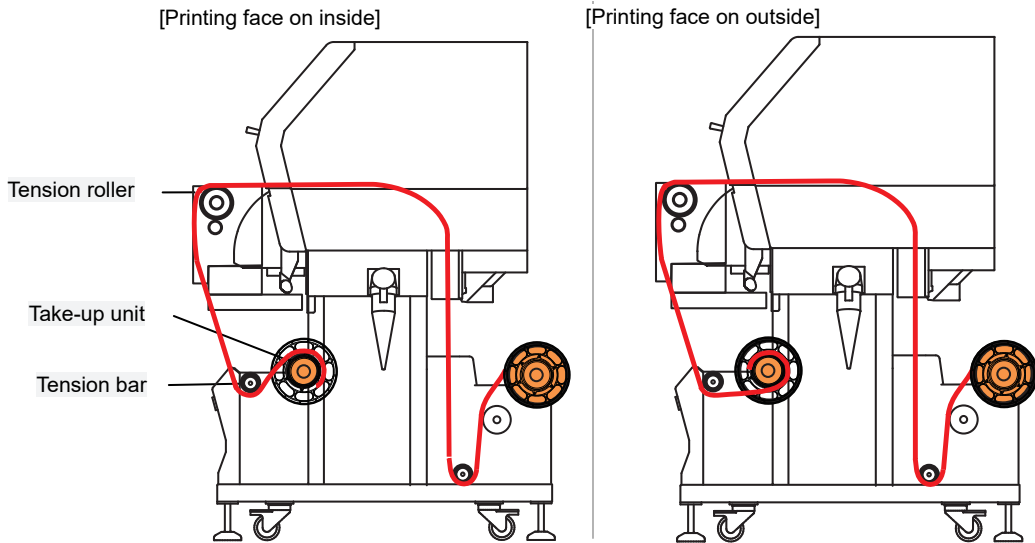

- **For paper media:**

Pass the media over the after cover and tension bar, then secure to the take-up unit.

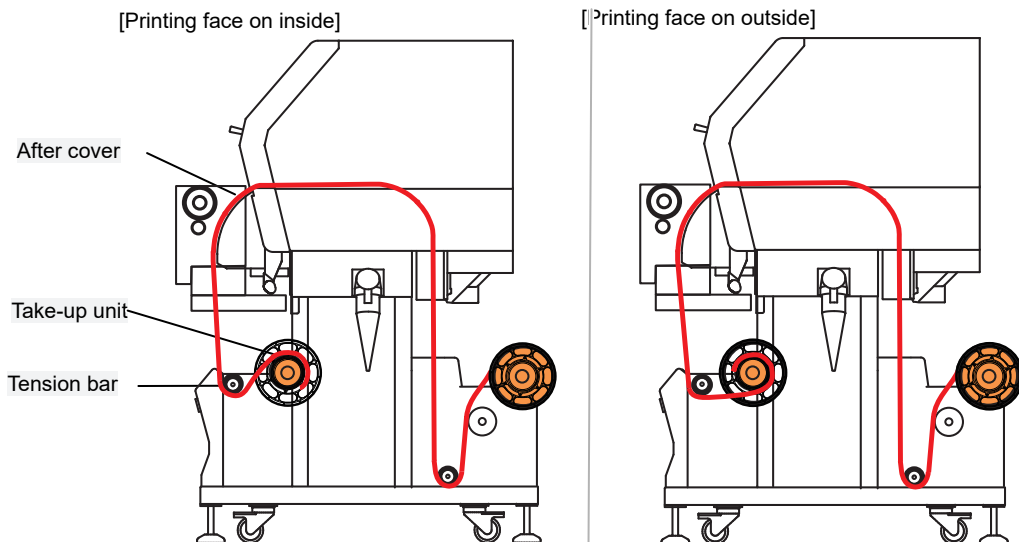

16 Secure the middle of the media to the paper core with adhesive tape, then secure the left and right sides of the media.

- Pull the lower edge of the media evenly on both the left and right sides, check to confirm that it is free of sagging and creasing, then affix the tape.

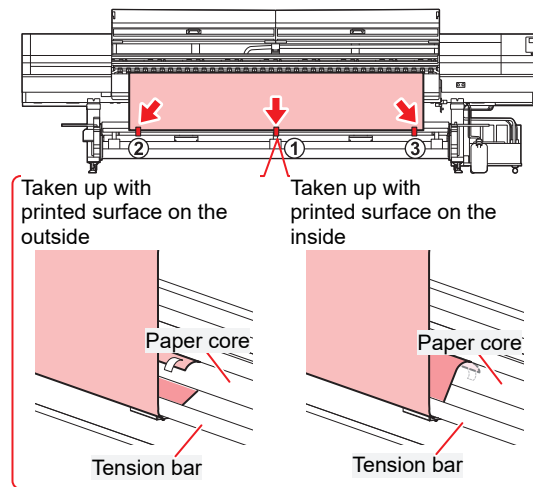

17 Feed the media so that it shows some slack, then switch the feed switch on the take-up unit to [MANUAL] and wind the media around the paper core two or three times.

18 Feed the media so that it shows some slack, then release the lock on the take-up side tension bar.

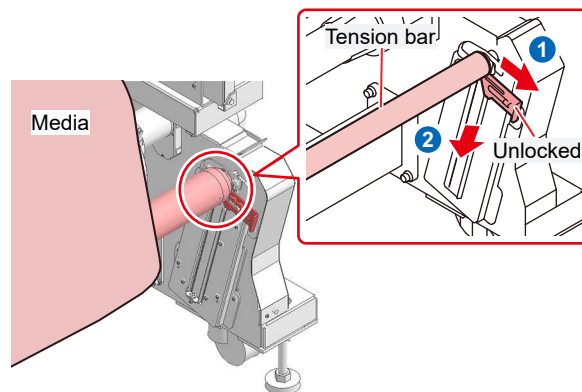

- Support the tension bar with your hand to keep it from dropping suddenly when the lock is released. Lower slowly. Sudden drops may damage the parts.

19 Once the media has been loaded in the take-up unit, press the [ENTER] key.

- The take-up tension bar origin is reset.

20 Check to confirm that there is no difference in media tension on the left and right for both the feed and take-up sides.

- If the tension differs between left and right, reload the media.

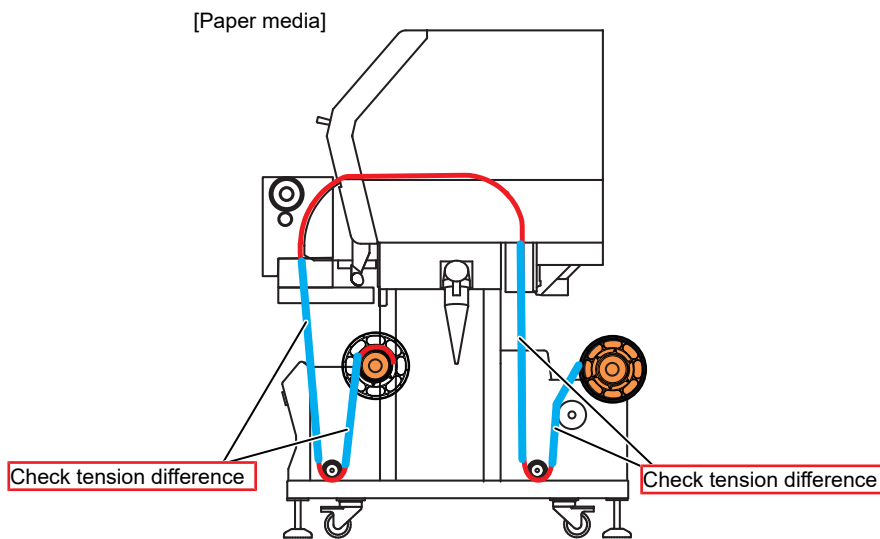
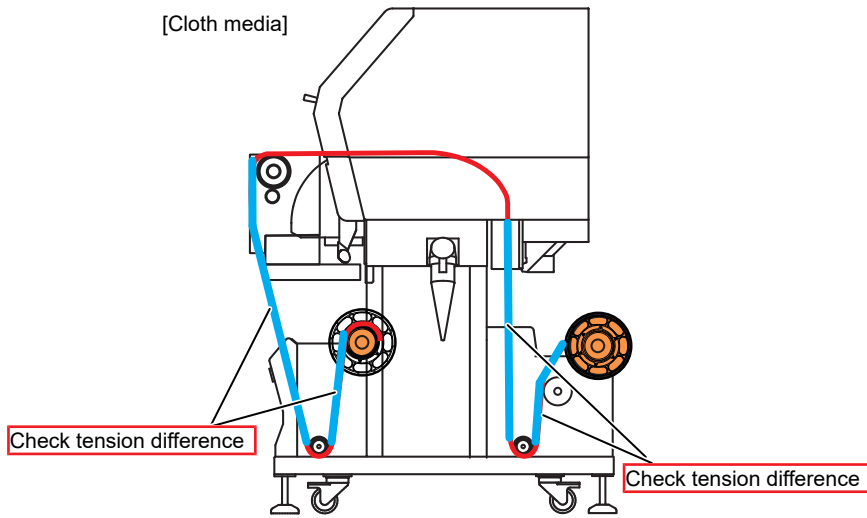

21 Secure the media in the media holder.

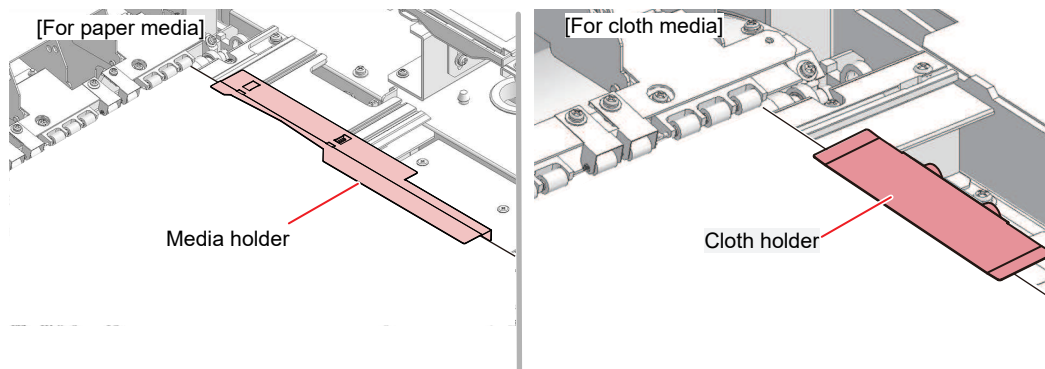

For paper media

- This machine detects the width of the media by means of media holders set on either side of the media. Please set the media holder securely.



- Do not use the media holders when printing on thicker paper media.
- When printing on cloth media, adjust the height of the stainless steel plates to suit the cloth thickness.

1 Remove the cloth holders

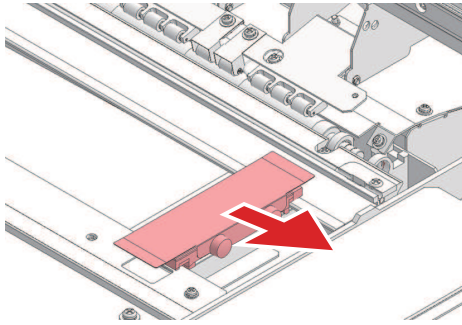

2 Loosen the knob screws to adjust the height.

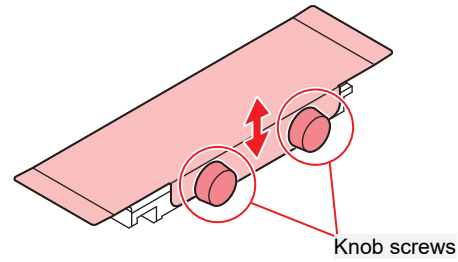

- The head height should also be adjusted when thick cloth is held by the cloth holders. The heads may be damaged if the head height is too low. ["Adjusting Print Head Height"](#)(P. 60)

22 Close the front cover.

23 Select the media to be used.

Media selection	1/2
<input checked="" type="radio"/> Transfer Paper	3100 mm
<input type="radio"/> Cloth	3200 mm
<input type="radio"/> Unregistered	
<input type="radio"/> Unregistered	
<input type="radio"/> Unregistered	



- To use unregistered media, select [Unregistered] to register the media. ["Registering the Media"](#)(P. 88)

24 Detect the media width.

- No change: Only the right side of the media is detected.
- Media width re-detection: The media width is detected.

Transfer Paper	
Media Width	3100 mm
	No change
	Media width



- Media width may not be detected correctly for certain colors or types of media. When media width cannot be detected correctly, set the media width detection method to "MANUAL".
- If the media width detection method is set to "MANUAL", set the media width manually ([MENU] > [Media Setting] > [Media Information] > [Media Width] > [Detection Type] P. 104).
- A notification reading "Media Set Position R" will appear after media width detection if the media is too far to the right of the specified position. Reload media in the specified position.
- If Media Remain Manage is set to "ON", the Input Media Length screen will be displayed. ([MENU] > [Media Setting] > [Media Information] > [Media Remain] > [Media Remain Manage] P. 104).



- Before cutting the media, either move the tension bar to the standby position and lock in place there or lower the tension bar to its lowest position using the operating panel (with the media untensioned), then cut the media manually using a craft knife or similar tool.



- Support the tension bar with your hand to keep it from dropping suddenly when the lock is released. Lower slowly. Sudden drops may damage the parts.
-

Setting Leaf Media

Leaf media such as decalcomania paper can be loaded only with the removable platens fitted into place.



- Do not load leaf media when using cloth media (with the removable platens not fitted).

1 Raise the clamp lever.

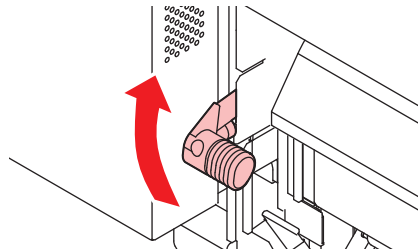

2 Open the front cover.

3 Select [OFF] for the tension bars used, then press the [ENTER] key.

Tension Bar Use Selection	
<input type="checkbox"/>	Feeding&Take-up
<input type="radio"/>	Feeding Only
<input type="radio"/>	Take-up Only
<input checked="" type="radio"/>	OFF

4 Insert the leaf media between the pinch rollers and the platens.

- Make sure that the right-hand edge of the media does not protrude to the right of the pinch rollers.

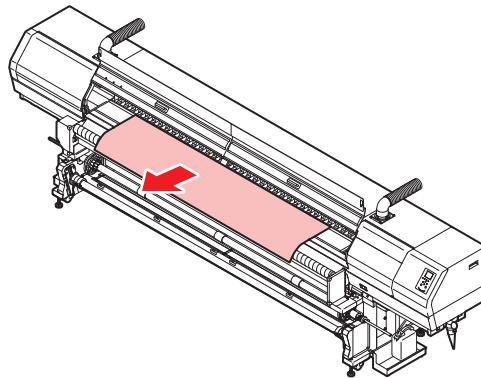

- The areas extending 20 mm from both sides of the media are margins.
- Use [Function Setting] > [WhiteSpace Setting] > [Margin] to change the settings

5 Secure the media in the media holder.

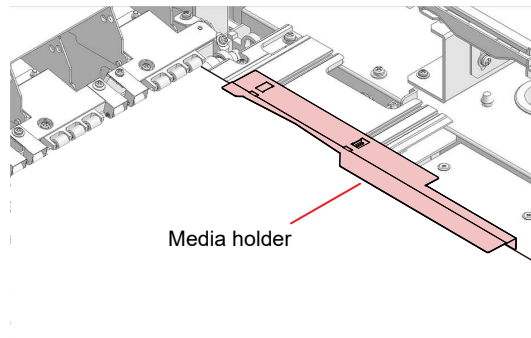

- Do not use the media holders when printing on thicker paper media.

6 Lower the clamp lever.

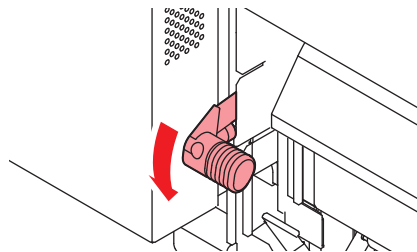

7 Close the front cover.

8 Press the [ENTER] key.

9 Press the key, then select [Leaf].

10 Set Logical Seek. ["Function Setting Menu"\(P. 111\)](#)

11 Select the media to be used.

Media selection	1/2
<input checked="" type="radio"/> Transfer Paper	3100 mm
<input type="radio"/> Cloth	3200 mm
<input type="radio"/> Unregistered	
<input type="radio"/> Unregistered	
<input type="radio"/> Unregistered	





- To use unregistered media, select [Unregistered] to register the media.  ["Registering the Media"\(P. 88\)](#)

12 Detect the media width.

- No change: Only the right side of the media is detected.
- Media width re-detection: The media width is detected.

Transfer Paper	
Media Width	3100 mm
	No change
	Media width



- Media width may not be detected correctly for certain colors or types of media. When media width cannot be detected correctly, set the media width detection method to "MANUAL".
 - If the media width detection method is set to "MANUAL", set the media width manually ([MENU] > [Media Setting] > [Media Information] > [Media Width] > [Detection Type]  P. 104).
 - A notification reading "Media Set Position R" will appear after media width detection if the media is too far to the right of the specified position. Reload media in the specified position.
 - If Media Remain Manage is set to "ON", the Input Media Length screen will be displayed. ([MENU] > [Media Setting] > [Media Information] > [Media Remain] > [Media Remain Manage]  P. 104).
-

Registering the Media

When the clamp lever is lowered with media being loaded, the Select Use Media screen is displayed. Registration is required to use media that is not registered on the machine.

1 Select [Unregistered].

Media selection	1/2
<input checked="" type="radio"/> Transfer Paper	3100 mm
<input type="radio"/> Cloth	3200 mm
<input type="radio"/> Unregistered	
<input type="radio"/> Unregistered	
<input type="radio"/> Unregistered	

2 Select the media type.

Media Type
<input checked="" type="radio"/> Decalcomania paper (thin)
<input type="radio"/> Decalcomania paper (mid)
<input type="radio"/> Decalcomania paper (thick)
<input type="radio"/> Cloth



- The cloth option is not displayed with the Sb411 ink set.

3 Select the media width detection type.

- AUTO: The media width is automatically detected.
- MANUAL: The media width is manually set.

Media Detection Type
Please Select.
AUTO
MANUAL



- Media width may not be detected correctly for certain colors or types of media. When media width cannot be detected correctly, set the media width detection method to "MANUAL".

4 Select the method for managing the media remaining amount.

- Select whether or not to manage the media remaining amount with the machine.

Media Remain Manage
Please Select.
ON
OFF

5 Enter the name to be displayed.

- If you do not register the name, press the [ENTER] key.

Media Name Change
Media 3
will be changed
(maximum 10 characters)

6 Select whether or not to register the set information.

do you optimize setting?
Execute Do not



- You can change the settings later. ["Media Setting Menu"\(P. 104\)](#)

● Media optimization settings

Optimizing the settings sets the various items as follows, depending on media type:

Settings	Default	Decalcoman ia paper (thin)	Decalcoman ia paper (mid)	Decalcoman ia paper (thick)	Cloth	Synthetic paper
MAPS	Auto	Auto	Auto	Auto	Auto	Auto
Vacuum fan strength	Strong	Strong	Strong	Strong	Strong ^{*1}	Strong
Vacuum fan constant operation	On	On	On	On	On ^{*1}	On
Feed speed (%)	Host	100	100	100	100	100
Pre Feed	Host	Off	Off	Off	Off	Off
Post-heater	Off	Off	Off	Off	Off	Off

*1. With cloth media (with removable platens not fitted), the vacuum fan will remain off regardless of the setting.

2.10 Setting the Heater Temperature

Set the heater temperature to suit the type of media used. The temperature can be altered while printing is in progress, but this may cause color variations to occur.



- Adjust the heater temperature to suit the media type and characteristics. Depending on the type, the media may expand or shrink or become rippled.



- The temperature setting in the RIP software takes precedence. If you are using the Mimaki RIP software (RasterLink), the recommended values are stored in the color profile.

Name	Overview
POST (Post-heater)	Allows ink to dry after printing. <ul style="list-style-type: none"> • The temperature at the lower part of POST is lower than the upper part.

- 1 On the LOCAL mode screen, select [HEATER].**
 - The Heater Temperature Setup screen appears.
- 2 Enter the heater temperatures, then press the [ENTER] key.**
 - Printing is possible once the heater temperatures reach the temperature settings ± 3 °C.

2.11 Test Printing

Print a test pattern to confirm that the ink prints correctly. Perform head cleaning if you observe any ejection failures (e.g., nozzle clogging or deflection). ☞ "Head Cleaning"(P. 93)

[For Sb411 ink]

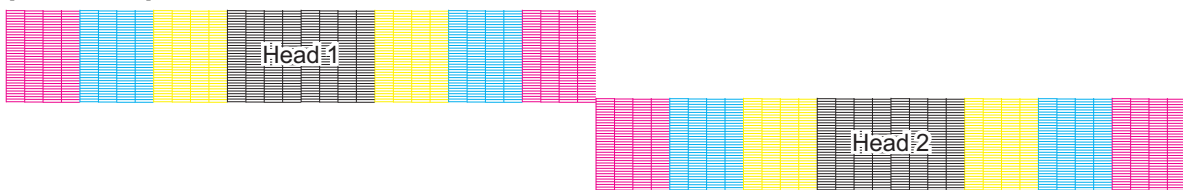

[For Sb420 ink]

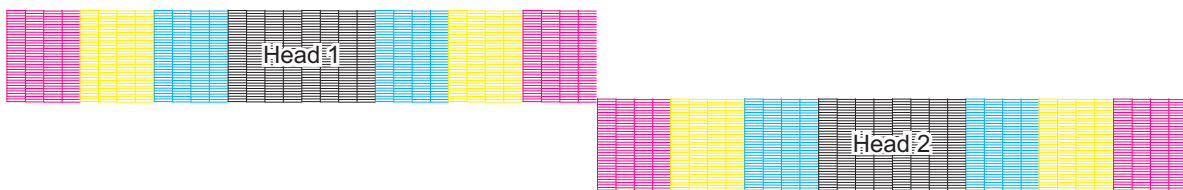

Check beforehand

- Was the print head adjusted? ☞ "Adjusting Print Head Height"(P. 60)
- Is media loaded? ☞ "Loading the Media"(P. 68)



- Load media at least 500 mm wide. You cannot print the entire pattern if media less than 500 mm wide is used.



- Select [Maintenance] > [Nozzle Recovery] > [Test Print], then select "ON" to perform nozzle recovery and test printing.
Registration is required to perform nozzle recovery. ☞ "Registering Nozzle Recovery"(P. 109)

Changing the Layout Direction for Test Printing

You can change the layout direction for test printing.

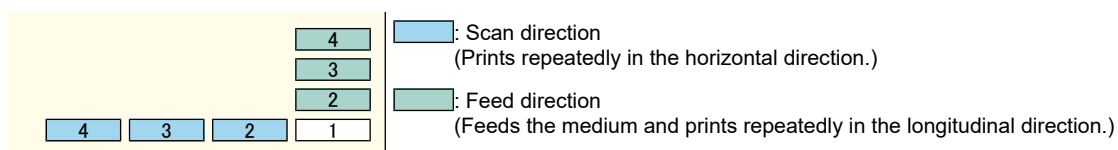

1 On the LOCAL mode screen, select [TEST PRINT/CLEANING] > [Test Print], then press the [ENTER] key.

- The Test Print menu is displayed.

2 Select [Scan Dir.] or [Feed Dir.], then press the [ENTER] key.

- Test printing starts.

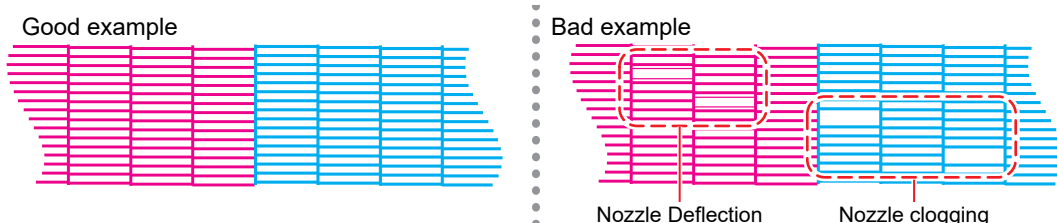

3 Check the print results.

Ejection Failures

Typical examples of ejection failures (e.g., nozzle clogging, deflection) are as shown below. In order to prevent printing in such a state, check whether the ink has been properly ejected regularly before printing.

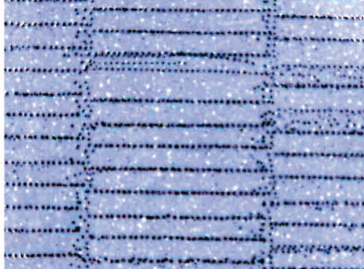

Nozzle Deflection

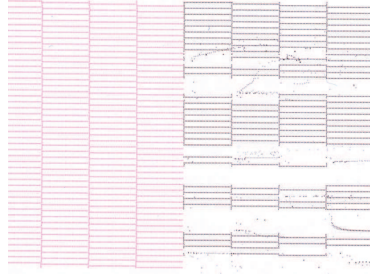

Nozzle clogging



Ink drips



Mist

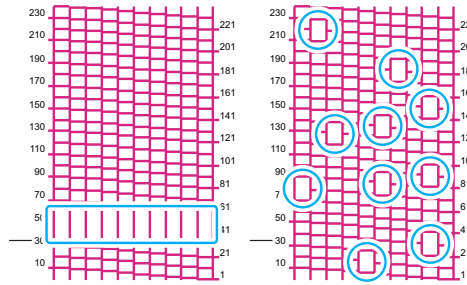

Mixed air



2.12 Head Cleaning

The following head cleaning methods are available. Choose the method based on test results. Cleaning is not possible when the [Ink Near End] or [Ink End] errors are displayed. Replace with new ink.  ["Replacing Ink"\(P. 42\)](#)

Item	Details
Soft	If the print shows a bent line (Nozzle deflection)
Normal	If the print shows a missing line (nozzle clogging)
Hard	If soft cleaning and normal cleaning fail to resolve ejection failures (e.g., nozzle clogging or deflection).

- 1** On the LOCAL mode screen, select [TEST PRINT/CLEANING] > [Cleaning], then press the [ENTER] key.
 - The Cleaning menu is displayed.
- 2** Select the cleaning type, then press the [ENTER] key.
- 3** Select the head to be cleaned, then press the [ENTER] key.
 - Check the check box. Heads with checked check boxes will be cleaned.
- 4** Run another test print and check the print results.
 - Repeat the cleaning and test printing process until the print results appear normal.



- Do the following if head cleaning fails to resolve the ejection failures (e.g., nozzle clogging or deflection).
 -  ["Cap Rubber Cleaning"\(P. 120\)](#)
 -  ["Print Head Nozzle Washing"\(P. 162\)](#)
 -  ["Wiper Cleaning"\(P. 122\)](#)

2.13 Feed Correction

Changing the media may affect the feed amount due to various factors, including the weight and thickness of the media and whether the take-up unit is used. Correct the drop position to suit the type of media used. Image defects (e.g., dark or light streaks) will result if the feed is not properly corrected.

Check beforehand

- Is media loaded? 🖱️ ["Loading the Media"\(P. 68\)](#)
- **Does the heater temperature suit the media to be used?** 🖱️ ["Setting the Heater Temperature"\(P. 90\)](#)
- For roll media, is the rear roll media free of sagging?
- When using the take-up unit, is the media mounted on the paper core of the take-up unit? 🖱️ ["Loading Media on to the Printer Main Unit"\(P. 75\)](#)

Feed Correction Procedure

Print a correction pattern, then enter the correction value. The value corrected here will also be updated on the Media Setting menu.



- When using the take-up unit, load media on the take-up unit before correcting.
- Set the media aligning the center datum with the media setting position guide plate. 🖱️ ["Media loading position"\(P. 72\)](#)
Check and adjust around the center of the machine.

1 On the LOCAL mode screen, select [ADJUST].

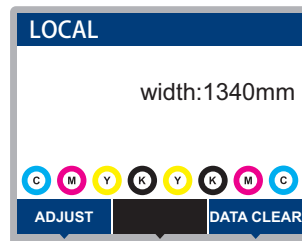

2 Select [Feed Comp.], then press the [ENTER] key.

- Correction pattern printing starts.

3 Check the print results.

- A correction value input screen appears.
- Adjust the bands so that the region between them is evenly colored.

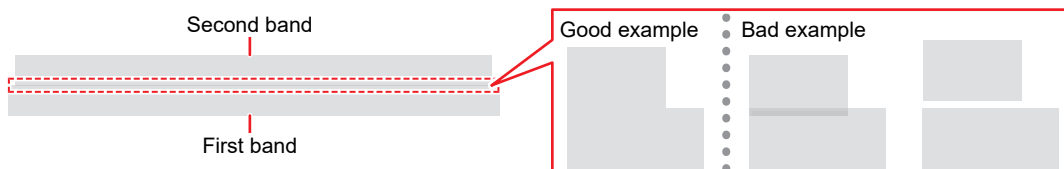

4 Enter the correction value, then press the [ENTER] key.

- "+" input: Increases the separation between bands.
- "-" input: Reduces the separation between bands.
- Increment the correction value by "30" to move the bands by approximately 0.1 mm.

- 5** Press the [ENTER] key.
 - Print another correction pattern to check.

Correcting the Media Feed During Printing

You can also correct the media feed amount in REMOTE mode or during printing.

- 1** Press [ADJUST] in REMOTE mode or during printing.
- 2** Enter the correction value, then press the [ENTER] key.
 - Correction value: -9999 to 9999
 - The value entered here will be updated immediately.

2.14 Correcting the Drop Position

Changing the media and print head height and temperature changes around the print head will also alter the drop positions. Correct the drop position to suit the type of media used. Image defects (e.g., overlaid lines or blurred images) will result if the drop position is not properly corrected.

Check beforehand

- Was the print head adjusted? "Adjusting Print Head Height"(P. 60)
- Is media loaded? "Loading the Media"(P. 68)
- **Does the heater temperature suit the media to be used?** "Setting the Heater Temperature"(P. 90)



- Load media at least 500 mm wide. You cannot print the entire pattern if media less than 500 mm wide is used.

Drop Position Correction Procedure

Print a correction pattern, then enter the correction value. The value corrected here will also be updated on the Media Setting menu. This must be adjusted for each print resolution.



- Set the media aligning the center datum with the media setting position guide plate. "Media loading position"(P. 72)
Check and adjust around the center of the machine.

- 1 On the LOCAL mode screen, select [ADJUST].

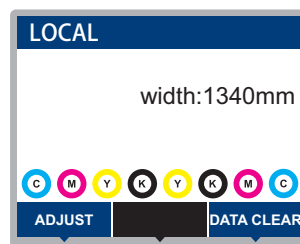

- 2 Select [Drop.PosCorrect], then press the [ENTER] key.

- 3 Select the resolution, then press the [ENTER] key.

- Select the resolution to be adjusted. When "All" is selected, correction patterns for all resolutions will be printed. "Media Setting Menu"(P. 104)



- The indicated resolutions are those in the scan direction.

- 4 Check the print results.

- A correction value input screen appears.
- Enter the position where the two upper and lower lines coincide.

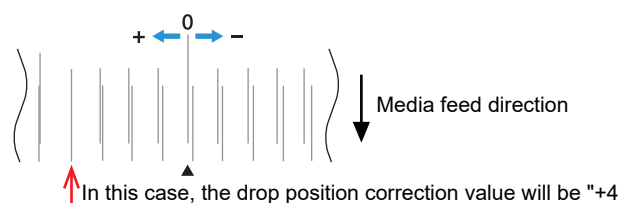

5 Enter the correction value, then press the [ENTER] key.

- Correction value: -40 to 40



- If the lines do not coincide when the correction value is within the range -40 to 40, the print head height may have been improperly adjusted. Adjust the print head height.
 ["Adjusting Print Head Height"\(P. 60\)](#)
-

6 Enter the correction value in the same way for pattern 2 and subsequent patterns.

2.15 Preparing RIP data

The explanation here applies to MIMAKI RIP software (RasterLink).



- Prepare suitable image data for printing.

1 Launch RasterLink.

- Click the icon on the PC desktop.



2 Select the image data to print.

- (1) Select [File] > [Open].
 - (2) Select the desired image data, then click [Open].
- If multiple printers are registered, select TS330-3200DS in "Printer Name".

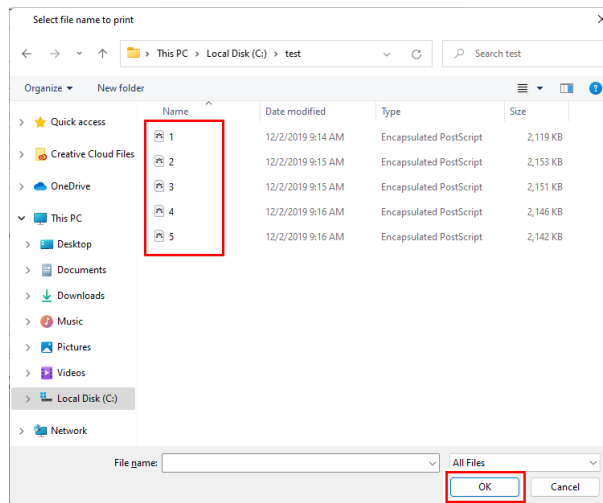

3 Select the image data imported.

- The image data is added in the tab for TS330-3200DS selected in "Printer Name".

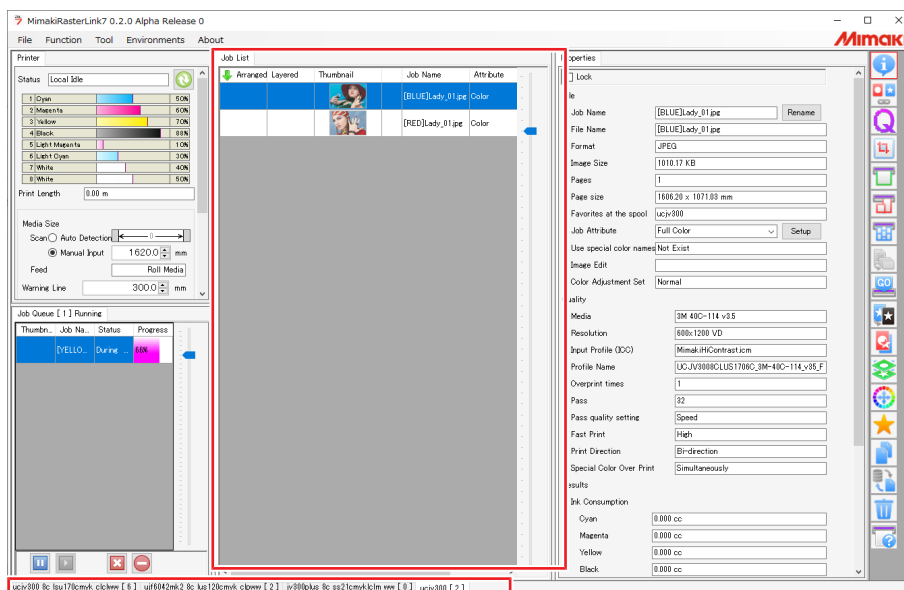

4 Edit the image.

- Specify the following settings by clicking the function icons shown on the right-hand side of the screen:

 (General Print): Specifies settings like enlargement/reduction and rotation.

 (Quality): Selects a color profile for the media and ink set loaded in this machine.



- For more information, refer to the RasterLink reference guide. <https://mimaki.com/download/software.html>
-

5 Print image data.

-  "Starting Printing"(P. 101)

(1) Click  (Execution) from the function icons on the right-hand side of the screen.

(2) Select "Immediate Print" or "RIP and Print", then click [Start].





- Media width must be reacquired after replacing media.

(1) Select the tab for TS330-3200DS in the main window.

(2) Click  (Update the printer status) in the Printer tab.

2.16 Printing

Check beforehand

- Have the platens been switched to suit the media to be used?  ["Selecting the Platens"\(P. 52\)](#)
- Was the print head adjusted?  ["Adjusting Print Head Height"\(P. 60\)](#)
- Is media loaded?  ["Loading the Media"\(P. 68\)](#)



- Condensation may form on the print head nozzle surface depending on the ambient temperature and humidity. The formation of condensation may cause ejection failures (e.g., nozzle clogging or deflection). Perform head cleaning if any ejection failures (e.g., nozzle clogging or deflection) occur during printing.  ["Head Cleaning"\(P. 93\)](#)

Changing the origin

The print start position can be altered. Use the LED pointer to set the origin.

- Print origin default value
 - Feed (longitudinal, X') direction: Approx. 75 mm to rear from platen cutting slot
 - Scan (lateral, Y') direction: 20 mm from right edge of media

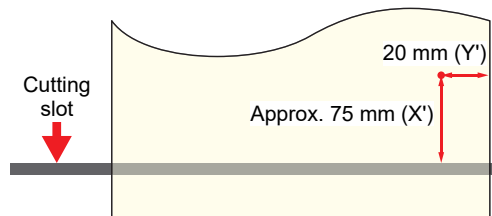

1 On the LOCAL mode screen, press .

- The Origin Setup screen appears.

2 Press to move the origin to the desired position.

- The carriage moves left and right and feeds the medium.



- The media cannot be fed backward when using cloth media (with the removable platens not fitted).

3 Press the [ENTER] key.

- The origin is updated.

Starting Printing

1 Send the RIP data from the PC.

-  "Preparing RIP data"(P. 98)



- If the message "Attention20A Driver version" appears, install the latest Mimaki driver.
<https://mimaki.com/download/inkjet.html>

2 Start printing.

- Printing starts once RIP data is received.

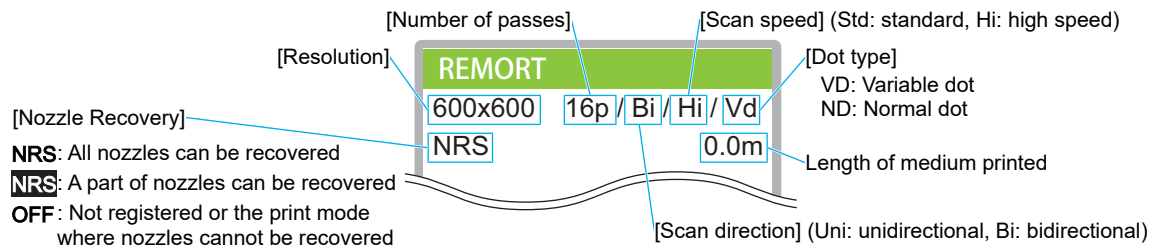

- Print speeds may differ for the same image data, depending on the width of the medium loaded, print origin position, and resolution.
- If an error occurs, the machine switches to LOCAL mode once printing is completed. Further printing is not possible.

Pausing Printing

1 Press [LOCAL] while printing is in progress.

- Printing is paused.
- If data is being sent from a PC, data transmission is paused at the PC.

2 Press [REMOTE].

- Printing resumes.



- No other functions can be used when printing is paused.

Stopping Printing (Data Clear)

- 1 On the LOCAL mode screen, select [DATA CLEAR].

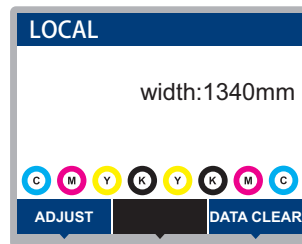

- 2 Press the [ENTER] key to clear the received data.
 - The receive buffer is cleared.

Chapter 3 Setup



This chapter

This chapter describes the [MENU] functions.

Media Setting Menu	104	Function Setting Menu	111
Maintenance Menu	107	Environment Setting Menu	113
Registering Nozzle Recovery	109	Machine Status Menu	115

3.1 Media Setting Menu



When you use the machine for the first time, the Select Use Media screen is displayed.  ["Registering the Media"\(P. 88\)](#) The media Information and correction value can be saved in advance for specific media.





The user can select to prioritize the settings on the machine or the settings on the PC. Setting individual menus to "Host" prioritizes PC settings. To prioritize settings for this machine, select a setting other than "Host".



- For more information on how to specify RIP software, refer to the RIP software operating manual.

● Menu List

Item	Setting		Details
	*1	*2	
Feed Comp.	-9999 to <u>0</u> to 9999	-	Corrects the media feed amount. Print a pattern and enter the correction amount.  "Feed Correction"(P. 94)
Drop.PosCorrect	-	-	Corrects the drop position for bi-directional printing.  "Correcting the Drop Position"(P. 96)
(Resolution)	*	-	Select the resolution to be corrected. When "All" is selected, correction patterns will be printed for all resolutions. * The available resolutions vary according to the model.
(Correction Value)	-40.0 to <u>0</u> to 40.0	-	Check the pattern and enter correction values.
Auto-correction	-	-	The auto-correction function (DAS: Dot Adjustment System) detects a correction pattern with the sensor and automatically corrects the drop position.
All	-	-	When "All" is selected, "Feed Comp." and "Drop.PosCorrect" are corrected. <ul style="list-style-type: none"> • Check to confirm that the media does not lift up. • Load white and clean media. • Media such as synthetic paper, tarpaulin, or cloth media may not be detected. • Do not send RIP data from the PC during pattern printing. • If automatic correction is unsuccessful, correct the position manually. [MENU] > [Media Setting] > [Feed Comp.] or [Drop.PosCorrect]
Feed Comp.	-	-	
Drop.PosCorrect	-	-	
(Resolution)	*	-	Select the resolution to be corrected. When "All" is selected, correction patterns will be printed for all resolutions, and the drop position is corrected automatically. * The available resolutions vary according to the model.
MAPS*	-	-	MAPS: Mimaki Advanced Pass System This function disperses the boundaries between passes to make feed streaks between passes less visible. Altering MAPS may alter the color. This function may be less effective with certain types of images. * The MAPS version will vary according to the model.

Item		Setting		Details
		*1	*2	
MAPS*		AUTO/ MANUAL	-	This should normally be set to "AUTO". When set to "MANUAL", the following items are displayed:
	Speed	50 to 100 %	-	Reducing speed will make streaks less visible. However, printing will be slower.
	Smoothing Level (Color)	0 to 100 %	-	Increasing smoothing makes streaks less visible. Make separate settings for color and spot color (white).
Heater		-	-	Set the heater temperature.  "Setting the Heater Temperature"(P. 90)
	POST	OFF /20 to 60 °C	-	Allows ink to dry after printing.
	OFF time	None / 0 to 90 min	-	Sets the time before turning the heater off after printing.
	Standby temp.	OFF / AUTO / 20 to 60 °C*	-	Sets the temperature of the heater in print standby. <ul style="list-style-type: none"> • OFF: The heater is not controlled during print standby, but heats the heater according to the heater temperature setting. • AUTO: Automatically controls heater temperature during print standby. • Specify temperature: Heats the heater to the set temperature during print standby. (* However, temperatures higher than the set heater temperature cannot be set.)
Media Information		-	-	Enter the media information.
	Media Type	-	-	Select the media type to be used. The available media types vary depending on the model.
	Media Width	-	-	Sets the media width detection method.
	Detection Type	AUTO/ MANUAL		<ul style="list-style-type: none"> • AUTO: The media width is automatically detected with the sensor. • MANUAL:  Press  to set the media width manually. <ul style="list-style-type: none"> – When media width cannot be detected correctly, set the media width detection method to "MANUAL".
	Media Remain	-	-	The remaining roll media amount can be displayed and printed out in REMOTE mode. The print length will be displayed when leaf media is in use.
	Media Remain Manage	ON/OFF	-	<ul style="list-style-type: none"> • ON: An input screen appears once the media width is detected.  Press  to set the media length. Press the [FUNC3] key on the "Origin Setup" screen to print the date and remaining media amount. • OFF: The remaining media amount is not displayed.
	Length	0 to 500 m	-	Enter the roll media length.
	Stop Printing	ON/OFF		Setting to "ON" stops printing when the Media Remain value reaches 0.
Detail Setting		-	-	This is used to set various functions.
Vacuum Fan	Strong /Weak/ Standard/Host	Strong		Sets the force with which the medium is held down. <ul style="list-style-type: none"> • This can be used to prevent media jamming and print head damage caused by the media lifting up.

Item		Setting		Details
		*1	*2	
	Continuous Running	<u>ON</u> /OFF		<ul style="list-style-type: none"> • ON: The media is constantly held down under vacuum. • OFF: The media is held down by vacuum only when required, such as during printing and feeding.
	Feed Speed	<u>Host</u> /10 to 100 to 200 %	100	Sets the media feed speed. <ul style="list-style-type: none"> • Depending on print conditions, the speed may not vary for certain settings. • Setting to 100 % or more reduces the time required to complete printing but may affect print quality due to insufficient drying time.
	Pre Feed	-	-	Sets the conditions for feeding media before printing.
	Setup	<u>OFF</u> / 200 to 1000 mm	-	Sets the distance the media is fed backward and forward before printing. <ul style="list-style-type: none"> • Moving the media backward and forward prevents it sticking to the platen and minimizes wrinkles in the media.
	Direction	<u>Round trip</u> / One way	-	Sets the media feed direction when feeding media before printing. <ul style="list-style-type: none"> • Round trip: After feeding a set distance of media forward, it feeds the same distance backward. • One way: Feeds a set length of media forward
	Decision time	<u>Always</u> / 1 to 60 min	-	Sets the interval the media is fed before printing. <ul style="list-style-type: none"> • Always: Perform a feed each time before printing. • Specify the time: Media feed is performed before printing only if a set amount of time has passed since the last print end time or media feed time.
	Media Name Change	-	-	You can change the name of a setting type. The name can include alphanumeric characters or symbols.
	Delete MediaInfo	-	-	Delete the set media information.

*1. The default settings are shown underlined.

*2. Settings applied if no settings can be made in the RIP software (host) or if this machine is prioritized.

3.2 Maintenance Menu

This menu is used for maintenance actions. It also lets the user perform nozzle recovery if nozzle clogging persists even after cleaning and nozzle washing.

● Menu List

Item	Setting ^{*1}	Details
Station Maint.	-	This moves the carriage to allow station and print head maintenance.
Carriage Out	-	
Move To Platen Right End	-	Cleans around the station, including the cap and wiper. ☞ "Cap Rubber Cleaning"(P. 120) ☞ "Wiper Cleaning"(P. 122)
Move To Maint. Space	-	Cleans around the print head. ☞ "Carriage Underside Cleaning"(P. 121) ☞ "Media Sensor Cleaning"(P. 127) ☞ "DAS (Automatic Correction Function) Sensor Cleaning"(P. 124)
Nozzle Wash	1 to 99 min	Washes the print head nozzle surface with maintenance liquid to resolve ejection failures (e.g., nozzle clogging or deflection). ☞ "Print Head Nozzle Washing"(P. 162)
Pump Tube Cleaning	-	Washes the suction pump tube (below the cap). ☞ "Ink Discharge Channel Cleaning"(P. 126)
Custody Wash	1 to 99 min	Perform this step if the machine will not be used for extended periods. The function washes nozzles and drainage channels to maintain the machine in optimal condition. ☞ "When this Printer is Left Unused for a Long Time"(P. 132)
Replace Wiper	-	Use this function when replacing the cloth wiper. Replacing the cloth wiper resets the cloth wiper used length stored in the machine. Cloth Wiper Replacement
Cap Replacement	-	Use this function when replacing the cap. Replacing the cap resets the cap usage time stored in the machine. ☞ "Cap Replacement"(P. 139)
Test Printing	-	Print a test pattern to confirm that the ink prints correctly. Perform head cleaning if you observe any ejection failures (e.g., nozzle clogging or deflection). ☞ "Test Printing"(P. 91)
Cleaning	-	Several head cleaning methods are available. Choose the head cleaning method based on test print results. ☞ "Head Cleaning"(P. 93)
Nozzle Recovery	-	Allows other nozzles to be used for printing if maintenance actions like nozzle washing fail to resolve print defects (e.g., nozzle clogging, deflection).
Print	-	Prints a pattern to check nozzle condition and register the nozzle. ☞ "Registering Nozzle Recovery"(P. 109)
Entry	-	Registers the nozzle without printing a pattern.
Reset	-	Initializes the details set.
Test Printing	ON/OFF	Sets whether to perform nozzle recovery before test printing.
Auto Maint.	-	Sets various maintenance actions to be performed automatically. Set the interval between individual maintenance actions.

Item	Setting ^{*1}	Details
		<ul style="list-style-type: none"> If the warning message "Replace Wasteinktank" appears, the automatic maintenance function is disabled.  "Waste Ink Tank Replacement"(P. 156)
Refresh	0.5/ <u>1.0</u> h	Sets the refresh interval (when a small amount of ink is ejected from the print head nozzles).
Pump Tube Cleaning	OFF/ <u>48h</u> /1 to 168 h	Sets the interval for washing the suction pump tube (below the cap).
Cleaning Interval	1 to <u>48</u> h	Sets print head cleaning intervals. This will help prevent nozzle clogging.
Type	<u>Normal</u> /Soft/ Hard	Sets the cleaning type for head cleaning.
Print Maint.	-	Sets the maintenance to be performed automatically midway during printing.
Auto Cleaning	-	Sets the conditions to perform head cleaning after the preset number of files are printed.
Setup	File/Length/ <u>Time</u> /OFF	Sets the conditions to perform head cleaning.
Interval	-	Sets head cleaning intervals.
(File)	1 to 1,000	Cleaning starts when the set number of files is exceeded.
(Length)	0.1 to 100.0 m	Cleaning starts when the set print length is exceeded.
(Time)	10 to <u>240</u> mins	Cleaning starts when the set print time is exceeded.
Type	<u>Normal</u> /Soft/ Hard	Sets the cleaning type for head cleaning.
Refresh	<u>Weak</u> / Standard/ Strong	Select the refresh (flushing) time during printing.
Air PG	-	Expels any air in the ink paths. <ul style="list-style-type: none"> Use this if Ink End is still displayed after ink replacement.
Ink Supply Maint.	-	Use this if a "Less Supply" error occurs.

*1. The default settings are shown underlined.

Registering Nozzle Recovery

Allows other nozzles to be used for printing if maintenance actions like nozzle washing fail to resolve ejection failures (e.g., nozzle clogging or deflection).



- Nozzle recovery can be specified for up to 20 nozzles per row. The time taken for printing remains unchanged even when nozzle recovery is set.



- Load media at least 500 mm wide. You cannot print the entire pattern if media less than 500 mm wide is used.

- 1 Position the media.**
- 2 On the LOCAL mode screen, select [MENU] > [Maintenance], then press the [ENTER] key.**
 - The Maintenance menu is displayed.
- 3 Select [Nozzle Recovery] > [Print], then press the [ENTER] key.**
 - Print a nozzle recovery pattern.
 - The Select Entry Nozzle screen appears once printing is complete.

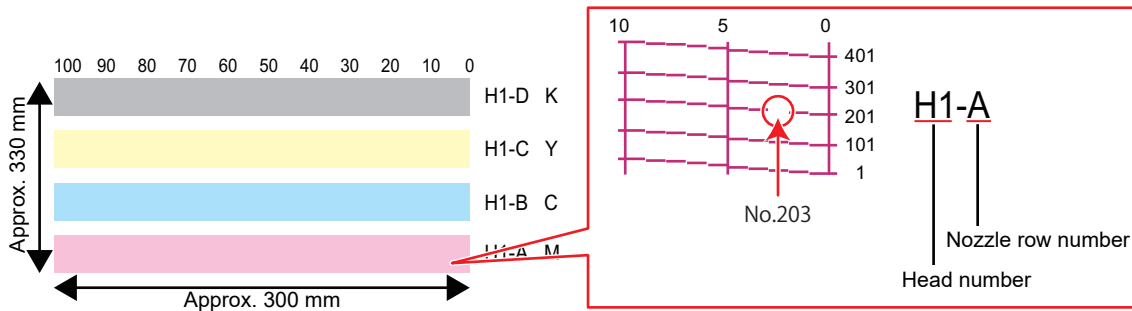

- 4 Select the "head number and nozzle row" for nozzle recovery, then press the [ENTER] key.**

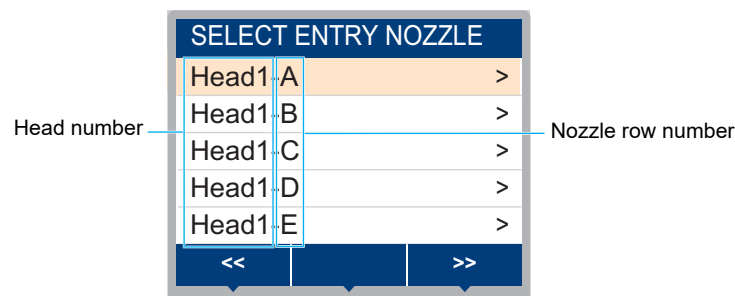

- 5 Enter the "nozzle number" for nozzle recovery, then press the [ENTER] key.**

- Select the entry number before entering the nozzle number.
- Nozzle recovery is set.

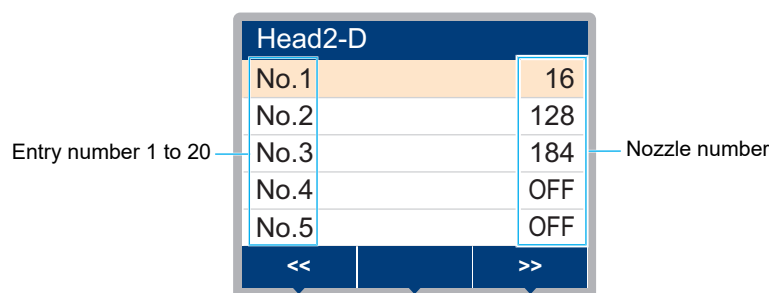

6 Press the [ENTER] key once entry is complete.



- Select [Maintenance] > [Nozzle Recovery] > [Test Print], then select "ON" to perform nozzle recovery and test printing.  ["Test Printing"\(P. 91\)](#)
-

3.3 Function Setting Menu

This is used to set various operations to ensure optimal machine performance.

● Menu List

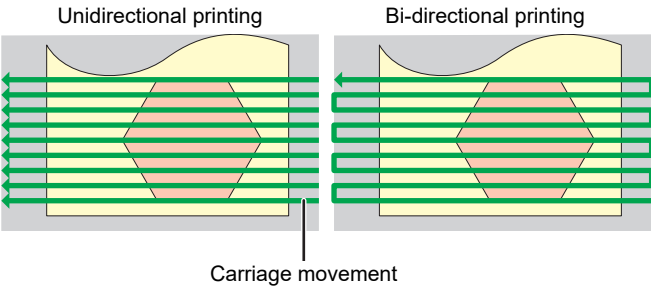
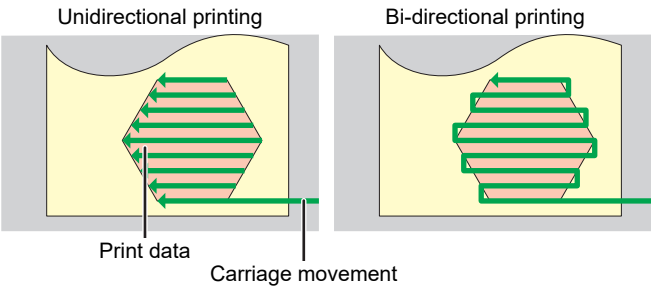
Item	Setting ^{*1}	Details
Logical Seek ^{*2}	Host /OFF/ON	<p>Sets the range of carriage movement.</p> <ul style="list-style-type: none"> OFF: Machine size area  <ul style="list-style-type: none"> ON: Print data area 
Option Roll Unit Select	-	Selects the roll unit used.
Feeding unit	ON /OFF	Set to "OFF" if the feeding unit is not used.
Take-up unit	ON /OFF	Set to "OFF" if the take-up unit is not used.
Tension roller	ON/ OFF	<ul style="list-style-type: none"> ON: The tension roller operates for printing even when the platens are used. ^{*3}
Drying Time	-	Sets the time for ink to dry.
Scan	Host /0.0 to 9.9 sec	<p>Sets the stop time of the carriage after each scan.</p> <ul style="list-style-type: none"> The MIMAKI RIP software (RasterLink) indicates this as "Pause Time per Scan".
Print End	Host /0 to 120 min	<p>Sets the stop time after printing. The next data is printed once the set time has elapsed.</p> <ul style="list-style-type: none"> The Mimaki RIP software (RasterLink) does not allow the user to specify Print End. If the machine is set to "HOST", the time will be "0".
Power Setting	-	Sets the times to turn the power on and off automatically.
Auto Power-off	5 to 15 to 60 min	Sets the time until the power is automatically turned off.
Auto Power-on	-	Sets the time to automatically turn on the power.
Setup	ON / OFF	Sets whether to turn on or off the power.
Time	0:00 to 23:59	Sets the time to turn on the power.
Day	Monday to Sunday	Sets whether to turn on or off the power on each day of the week.

Item	Setting ^{*1}	Details
Exhaust fan	<u>ON</u> /OFF	Set to "OFF" if the exhaust fan is not used during printing.
WhiteSpace Setting	-	Sets the offset value from the media left and right standard margins (20 mm).
Margin	-	<ul style="list-style-type: none"> The left and right margins should be set to at least -5 mm when using the media holder. This eliminates the risk of printing on top of the media holder. The Mimaki RIP software (RasterLink) does not allow the user to specify margins. If the machine is set to "Host", the offset value will be "0 mm" for the left and right margins.
Margin/Left	<u>Host</u> /-10 to 85 mm	
Margin/Right		
Space Btwn PP.	<u>None</u> /10 to 500 mm	<p>The space between prints can be eliminated for continuous printing.</p> <ul style="list-style-type: none"> Reducing the space length may cause media sagging, resulting in discrepancies in the distance the media is fed. The actual space may be wider than set, depending on the size of image data and number of passes in the feed direction.
Space Feed Mode	<u>Intermittent</u> / Continuous	<p>Alters the feed method for blank space included in the image data.</p> <ul style="list-style-type: none"> Intermittent: Uses intermittent feeding based on the timing of a fraction of the pass. Continuous: Feeds forward by skipping blank parts.
View Feed	<u>ON</u> /OFF	Sets whether or not to feed the media forward to view the print results—for example, during test printing.
Auto Remote	<u>ON</u> /OFF	Sets whether to automatically switch to REMOTE mode and start printing if data is received locally.

*1. The default settings are shown underlined.

*2. Depending on the print width and print position of the print data, logical seek may be disabled. (To protect the nozzle surface)

*3. If the platens are not fitted, the tension roller will operate regardless of this setting.

3.4 Environment Setting Menu

This is used to set various operations to ensure optimal machine performance.

● Menu List

Item	Setting ^{*1}	Details
LANGUAGE	English / 日本語 / Deutsch / Português / Español / Italiano / Korean	Sets the display language.
Time Set	-20 to 0 to +4 h	Sets the current time and date. (With respect to JST) <ul style="list-style-type: none"> This can be set within the range of -20 to +4 hours.
Key Buzzer	ON/OFF	Sets an audible tone when keys are pressed. <ul style="list-style-type: none"> Audible signals indicating errors, warnings, and operation end cannot be muted, even if "OFF" is selected for this setting.
Unit Setting	-	Set the display units.
Temp.	°C/°F	Sets the display unit for temperature (Celsius/Fahrenheit).
Length	mm /inch	Sets the display units for length and area. <ul style="list-style-type: none"> Some items are displayed in "mm" even if "inch" is selected.
Network	-	Sets the network address. The machine must be restarted to enable this setting.
Check IP Address	-	Displays the machine's current IP address. <ul style="list-style-type: none"> It may take some time to determine the IP address. If the IP address cannot be determined, the display will indicate "0.0.0.0".
Check MAC Address	-	Displays the machine's current MAC address.
DHCP	ON/OFF	Select "ON" to use the IP address assigned by the DHCP server.
AutoIP	ON/OFF	Select "ON" to use the IP address set by the AutoIP protocol. Note that DHCP takes priority if DHCP is set to "ON".
Ip Address	-	Sets the IP address used by the machine. <ul style="list-style-type: none"> This can be set when both [DHCP] and [AutoIP] are disabled.
Default Gateway	-	Sets the default gateway used by the machine. <ul style="list-style-type: none"> This can be set when both [DHCP] and [AutoIP] are disabled.
DNS Address	-	Sets the DNS server address used by the machine. <ul style="list-style-type: none"> This can be set when both [DHCP] and [AutoIP] are disabled.
Sub Net Mask	-	Sets the subnet mask used by the machine. <ul style="list-style-type: none"> This can be set when both [DHCP] and [AutoIP] are disabled.
Remote Control	-	An application (MRA: Mimaki Remote Access) is required to use the remote control function. MRA is a remote access tool installed on a computer or smartphone that allows viewing of product information and panel operation from a remote location away from the machine (within the same network segment).
Setup	Enable/Disable	Enable/disable remote control.







Item	Setting ^{*1}	Details
	PIN code	<p data-bbox="614 185 1331 248">Enter the same PIN code as MRA. The PIN code is used for authentication between the machine and MRA.</p> <ul data-bbox="632 253 1331 315" style="list-style-type: none"> <li data-bbox="632 253 1331 315">• When the machine is set to "0000", MRA can access the machine with any PIN code.
	KeyLife	<p data-bbox="614 338 1418 400">Sets the time interval before disconnecting the machine and MRA if no operations are performed using MRA.</p>
Machine Reset	-	Initializes the details set.

*1. The default settings are shown underlined.

3.5 Machine Status Menu

This is used to check machine information.

● Menu List

Item		Details
Usage	WIPING	The number of wiping cycles is displayed. <ul style="list-style-type: none"> To reset the number of wiping cycles, press the [FUNC2] key while the level is displayed.
	Capping Use Days	Displays the number of days since the cap was replaced.
	Print Length	Displays the total length printed.
	Print Area	Displays the total area printed.
	Use Time	Displays the total time the power has been turned on.
Maintenance History	Maintenance	Displays a record of maintenance function execution (up to 10). <ul style="list-style-type: none"> Cleaning  P. 93, Wash Wiping  P. 93, Pump Tube Cleaning  P. 126, Nozzle Washing  P. 162
	Replace Wiper	Displays a record of wiper replacement (up to 5).  P. 136
	Ink replacement	Displays a record of ink pack replacement for each ink slot (up to 5).  "Replacing Ink"(P. 42) <ul style="list-style-type: none"> Slot 1 to 8
	Cap Replacement	Displays a head cap replacement history.  "Cap Replacement"(P. 139)
Version		Displays the machine firmware and other versions.
Error History		Displays the error and warning history. <ul style="list-style-type: none"> These are listed in chronological order. Use the keys to cycle through occurrence time/date and error/warning information.
List		This is used to print machine information.

Chapter 4 Maintenance



This chapter

To ensure years of precise performance, maintain the machine periodically based on frequency of use.

Read the maintenance precautions thoroughly before maintaining this product.

Maintenance Precautions	118	Replacement of Consumable Item	135
Maintenance Methods	119	Consumable Item Replacement Timing	135
Maintenance Items and Timing	119	Wiper Replacement	136
Ink Maintenance	120	Wiper Cleaner Replacement	137
Cap Rubber Cleaning	120	Cap Replacement	139
Carriage Underside Cleaning	121	Replacing the Absorber Around the Station	141
Wiper Cleaning	122	Exhaust Fan Filter Replacement	144
Flushing Unit Cleaning	124	Flushing Unit Absorber Pad Replacement	145
DAS (Automatic Correction Function) Sensor Cleaning	124	Pinch Roller Replacement	148
Ink-Receiving Pan Spacer Cleaning	125	Media Holder and Cloth Holder Replacement	149
Ink Slope Cleaning	126	Ink Supply Unit Ink Absorber Replacement	155
Ink Discharge Channel Cleaning	126	Waste Ink Tank Replacement	156
Media Sensor Cleaning	127		
Media Holder and Cloth Holder Cleaning	128		
Jam Sensor Detecting Plate Cleaning	129		
Platen and Platen Wire Cleaning	130		
Pinch Roller and Grit Roller Cleaning	130		
Tension Roller Cleaning	131		
Cover (Exterior) Cleaning	132		
When this Printer is Left Unused for a Long Time	132		

4.1 Maintenance Precautions



- This machine includes parts that must be replaced periodically. We therefore recommend taking out a maintenance contract. Carry out maintenance periodically and replace consumable items to prevent quality defects and accidents.

⚠ WARNING



- Clean periodically. Debris and dust will accumulate on electrical components when the machine is used for extended periods. There is a risk of failure, electric shock, or fire due to current leakage.
- Do not clean by blowing—e.g., avoid using air blowers. Doing so may lead to failure, electric shock, or fire involving the machine if airborne debris or dust gets inside electrical components. Wipe using a soft cloth soaked in diluted neutral detergent and thoroughly wrung out. A vacuum cleaner may also be used for cleaning.



- Be careful to prevent liquids from getting inside the machine. Otherwise there is a risk of failure, electric shock, or fire.

⚠ CAUTION



- For heavy soiling, wipe using a soft cloth soaked in diluted neutral detergent and thoroughly wrung out.



- Pay close attention to ventilation and be sure to wear safety glasses, gloves, and a mask when handling ink, maintenance liquid, waste ink, or other solutions used with the machine. Leaking ink may adhere to the skin or get into the eyes or mouth.

















NOTICE



- Never touch the print head nozzle surface. Do not allow water or alcohol to come into contact with the print nozzle surface. This will increase the risk of machine failure or ejection failures (e.g., nozzle clogging or deflection).
- Do not use cotton swabs to clean around the head or carriage. Fibers from cotton swabs may adhere to the head nozzle surface and lead to ejection failures (e.g., nozzle clogging or deflection).
- Do not splash ink or maintenance liquid on the covers. Exposure to splashing ink or maintenance liquid may damage or deform the cover.
- Do not use benzine, thinner, or any chemical agent containing abrasives. Use of these chemicals may result in damage to or deformation of parts.
- Do not use organic solvents such as acetone and IPA. Doing so may damage the machine.
- Do not move the carriage by hand. To move the carriage, use the carriage out function on the menu.

4.2 Maintenance Methods

Maintenance Items and Timing

Timing	Item
Every three days, at the start of the work	Shake the ink.  "Ink Maintenance"(P. 120)
Every three days or when not used for more than three days.	Clean the flushing unit.  "Flushing Unit Cleaning"(P. 124)
At the end of the week's work	Clean the cap rubber.  "Cap Rubber Cleaning"(P. 120)
	Clean the underside of the carriage.  "Carriage Underside Cleaning"(P. 121)
	Check the waste ink levels in the waste ink tank.  "When "Check Waste Ink Tank" message appears"(P. 156)
When the media is replaced	Clean the ink-receiving pan spacers.  "Ink-Receiving Pan Spacer Cleaning"(P. 125)
	Clean the tension roller.  "Tension Roller Cleaning"(P. 131)
	Clean the ink slope.  "Ink Slope Cleaning"(P. 126)
Every month	Clean around the wiper.  "Wiper Cleaning"(P. 122)
	Clean the DAS sensor.  "DAS (Automatic Correction Function) Sensor Cleaning"(P. 124)
	Clean the ink discharge channel.  "Ink Discharge Channel Cleaning"(P. 126)
	Clean the media sensor.  "Media Sensor Cleaning"(P. 127)
	Clean the media holders and cloth holders.  "Media Holder and Cloth Holder Cleaning"(P. 128)
	Clean the jam sensor detecting plate.  "Jam Sensor Detecting Plate Cleaning"(P. 129)
	Clean the platen.  "Platen and Platen Wire Cleaning"(P. 130)
	Clean the pinch rollers and grit rollers.  "Pinch Roller and Grit Roller Cleaning"(P. 130)
	Clean the cover (exterior).  "Cover (Exterior) Cleaning"(P. 132)
When not used for more than a week	Clean the cap and wash the ink discharge channels. After cleaning, store without turning off the main power supply.  "When this Printer is Left Unused for a Long Time"(P. 132)

Items Required for Maintenance

To order replacement consumable items, contact your local dealer or our service office. For more information on consumable items, refer to our website (<https://mimaki.com/supply/inkjet.html>).



- Do not store consumable items in locations where children may enter.

Ink Maintenance

If ink constituents are sedimented, the ink density may become uneven. We recommend shaking the ink periodically to keep printing consistent.

Once every three days.



- **Shake taking care that the ink eco-cases do not become detached** from the ink supply unit. Ink may leak out if the ink eco-cases become detached.

1 Shake the ink eco-cases slowly approximately 10 times.

- Shake the ink eco-cases back and forth while holding the top.

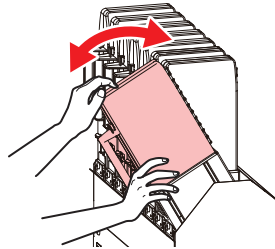

- Be sure to shake the ink eco-case back and forth by holding its top. Ink may leak out if the top is not held and the ink eco-cases become detached.

Cap Rubber Cleaning

The cap prevents the print head nozzle surface from drying out. Continuing to use a dirty cap may affect ink take-up and lead to ejection failures (such as nozzle clogging or deflection).



- Be careful to avoid leaving fragments from the cleaning stick behind when cleaning. These fragments will increase the risk of ejection failures (e.g., nozzle clogging or deflection).

1 On the LOCAL mode screen, select [MENU] > [Maintenance], then press the [ENTER] key.

- The Maintenance menu is displayed.

2 Select [Station Maint.] > [Carriage Out] > [Move To Platen Right End], then press the [ENTER] key.

- The carriage moves over the platen.

3 Open the maintenance cover on the right side.

- (1) Remove the two screws at the bottom of the right maintenance cover.
- (2) Hold the bottom edge of the maintenance cover, then pull out and forward to remove.

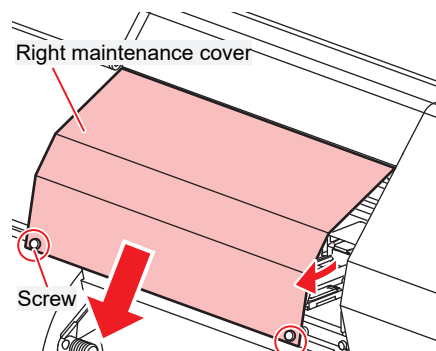

4 Clean the cap rubber.

- Wipe off any ink and dust adhering using a cleaning stick moistened with maintenance liquid. Wipe off the maintenance liquid. Make sure none remains.
- Clean the areas indicated in red in the diagram (the entire interior and exterior of the cap rubber, the tabs, and the mesh retainers).

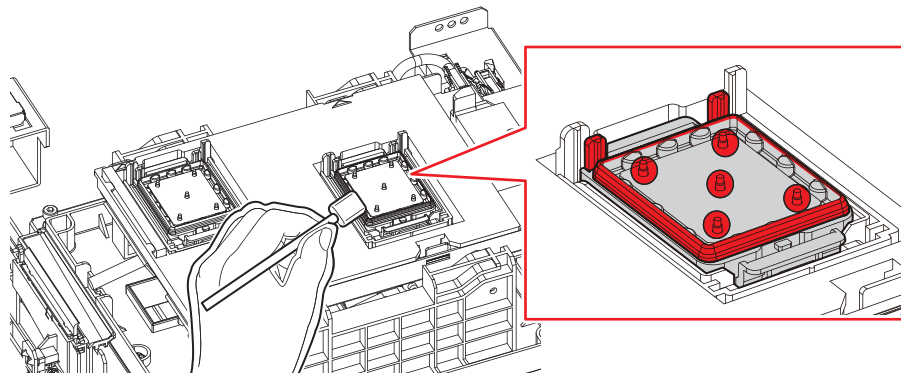

5 Close the maintenance cover, then press the [ENTER] key.

Carriage Underside Cleaning

The underside of the carriage becomes coated with ink wiped off by the wiper. Continuing to use the dirty carriage underside will rub dried ink and attached dust on to the media, resulting in contaminated prints.

The print head uses an extremely delicate mechanism. Take great care when handling it.



- Be careful to avoid leaving fragments from the cleaning stick behind when cleaning. These fragments will increase the risk of ejection failures (e.g., nozzle clogging or deflection).

1 On the LOCAL mode screen, select [MENU] > [Maintenance], then press the [ENTER] key.

- The Maintenance menu is displayed.

2 Select [Station Maint.] > [Carriage Out] > [Move To Maint. Space], then press the [ENTER] key.

- The carriage moves to the maintenance space.

3 Open the maintenance cover on the left side.

- (1) Remove the three screws at the bottom of the maintenance cover.
- (2) Hold the bottom edge of the maintenance cover, then push on the area circled in blue and pull out and forward to remove.

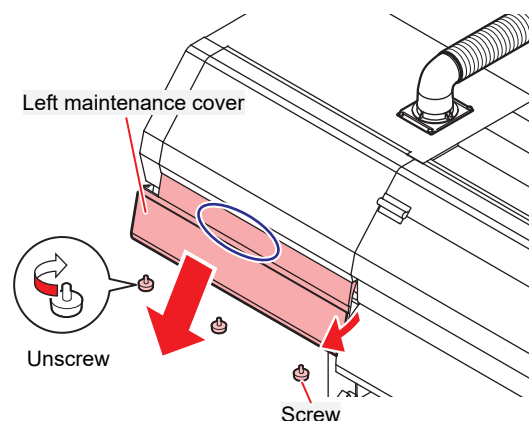

4 Clean around the print head.

- Wipe off any ink and dust adhering using a cleaning stick moistened with maintenance liquid. Wipe off the maintenance liquid. Make sure none remains.

Clean the print head sides and all around the nozzle plate using a cleaning stick.

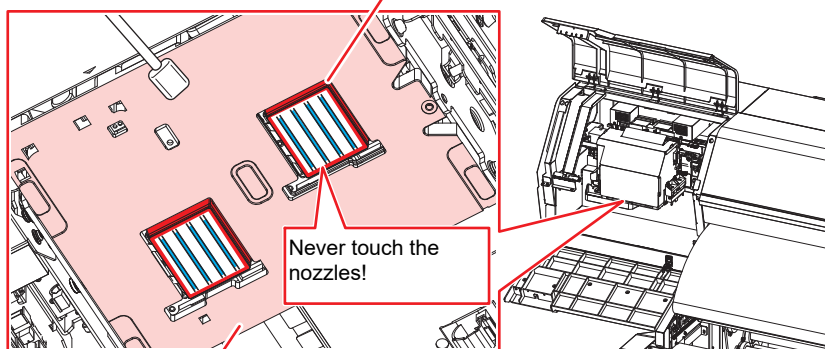

Clean using a cleaning stick or soft cloth.



- Never touch the print head nozzle surface.

5 Once cleaning is complete, close the cover, then press the [ENTER] key.

Wiper Cleaning

The wiper wipes off ink adhering to the print head nozzle surface. Continuing to use with a dirty wiper will cause dried ink and attached dust to rub against the head nozzle surface, and lead to ejection failures (e.g., nozzle clogging or deflection).



- Be careful to avoid leaving fragments from the cleaning stick behind when cleaning. These fragments will increase the risk of ejection failures (e.g., nozzle clogging or deflection).

- On the LOCAL mode screen, select [MENU] > [Maintenance], then press the [ENTER] key.
 - The Maintenance menu is displayed.
- Select [Station Maint.] > [Carriage Out] > [Move To Platen Right End], then press the [ENTER] key.
 - The carriage moves over the platen.
- Open the maintenance cover on the right side.
 - Remove the two screws at the bottom of the right maintenance cover.
 - Hold the bottom edge of the maintenance cover, then pull out and forward to remove.

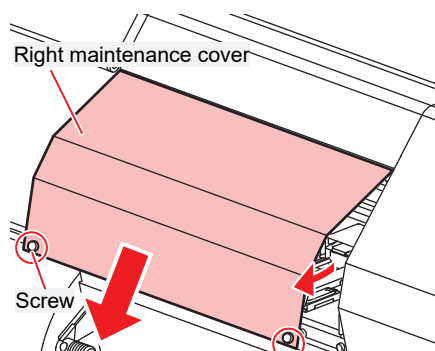

4 Remove the wiper.

- Hold the lug at the rear of the wiper bracket, then pull out the wiper.

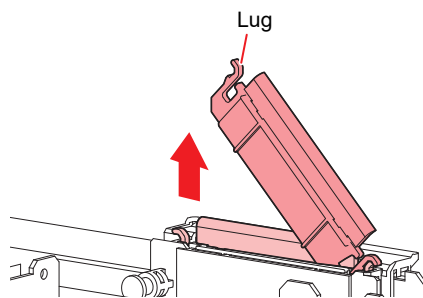

5 Clean the wiper and bracket.

- Wipe off any ink and dust adhering using a cleaning stick moistened with maintenance liquid. Wipe off the maintenance liquid. Make sure none remains.

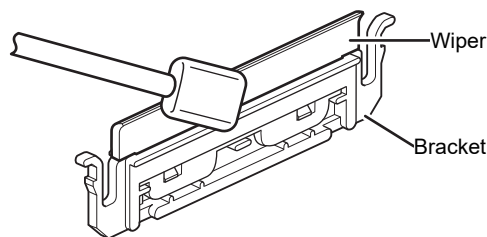

- Replace dirty or warped wipers with new ones. Wiper Replacement

6 Clean the wiper slider.

- Wipe off any ink and dust adhering using a cleaning stick moistened with maintenance liquid. Wipe off the maintenance liquid. Make sure none remains.

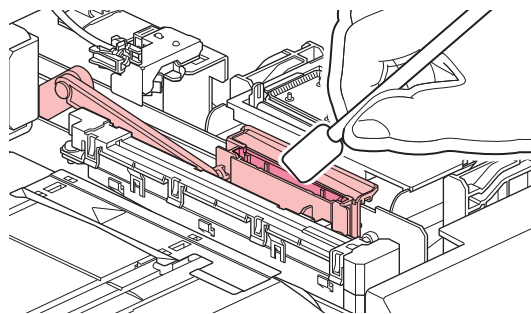

7 Reattach the wiper at the original position.

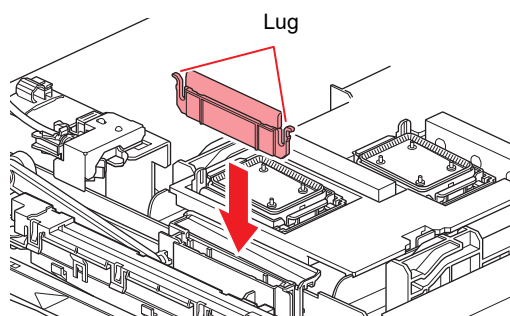

- 8** Once cleaning is complete, close the cover, then press the [ENTER] key.

Flushing Unit Cleaning

Continuing to use the dirty carriage underside will rub dried ink and attached dust on to the media, resulting in contaminated prints.

- 1** Slowly pour 100 cm of water or maintenance liquid over both the left and right flushing units.

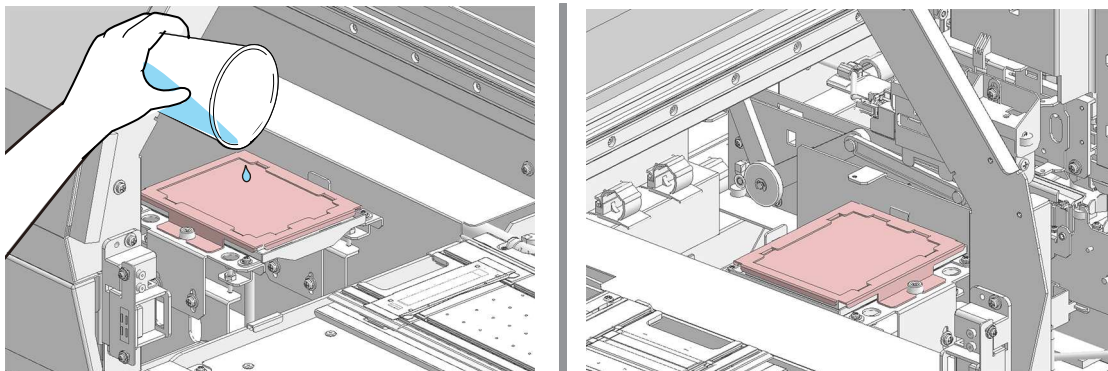

- Take care not to allow liquids to get inside the machine. Otherwise there is a risk of failure, electric shock, or fire.

DAS (Automatic Correction Function) Sensor Cleaning

The DAS sensor is located on the carriage underside. If dust or debris accumulates on the sensor, DAS (👉 P. 104) may not function.

- 1** On the LOCAL mode screen, select [MENU] > [Maintenance], then press the [ENTER] key.
 - The Maintenance menu is displayed.
- 2** Select [Station Maint.] > [Carriage Out] > [Move To Maint. Space], then press the [ENTER] key.
 - The carriage moves to the maintenance space.
- 3** Open the maintenance cover on the left side.
 - (1) Remove the three screws at the bottom of the maintenance cover.
 - (2) Hold the bottom edge of the maintenance cover, then push on the area circled in blue and pull out and forward to remove.

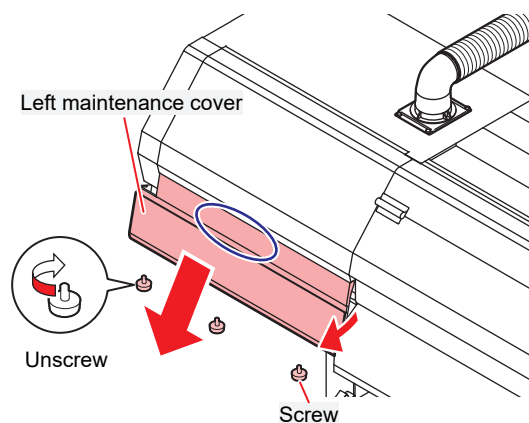

4 Clean the DAS sensor.

- Wipe clean using cotton swabs or a soft cloth.

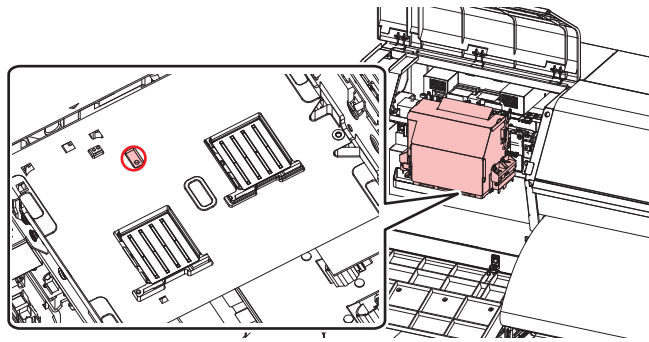

- For heavy soiling, wipe using a soft cloth soaked in diluted neutral detergent and thoroughly wrung out.

5 Once cleaning is complete, close the cover, then press the [ENTER] key.

Ink-Receiving Pan Spacer Cleaning

Remove the spacers and wash them to remove any ink adhering to the ink-receiving pan spacers, for example when replacing the media.

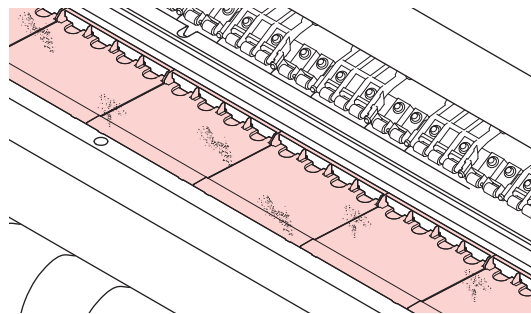

- Take care not to allow liquids to get inside the machine. Otherwise there is a risk of failure, electric shock, or fire.
- **Do not pour water directly over the ink-receiving pan spacers while they are mounted on the machine.**



- For heavy soiling, remove the ink-receiving pan spacers, then wipe using a soft cloth soaked in diluted neutral detergent and thoroughly wrung out.



- Do not use organic solvents such as acetone and IPA. Doing so may damage the machine.

Ink Slope Cleaning

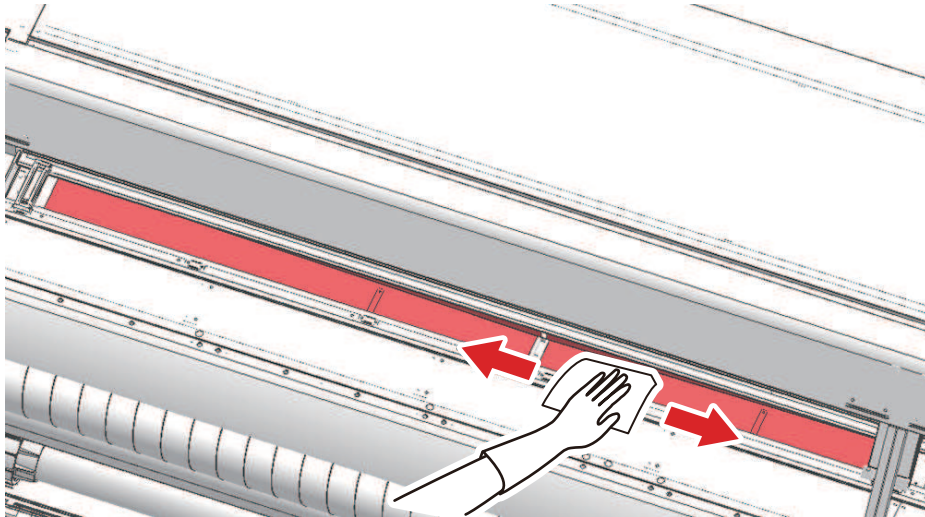

- Take care not to allow liquids to get inside the machine. Otherwise there is a risk of failure, electric shock, or fire.
- **Do not pour water directly over the ink slope.**



- For heavy soiling, wipe using a soft cloth soaked in diluted neutral detergent and thoroughly wrung out.



- Do not use organic solvents such as acetone and IPA. Doing so may damage the machine.

Ink Discharge Channel Cleaning

Clean the ink discharge channel regularly to prevent clogging of the ink discharge channel below the cap.

- 1 On the LOCAL mode screen, select [MENU] > [Maintenance], then press the [ENTER] key.**
 - The Maintenance menu is displayed.
- 2 Select [Station Maint.] > [Pump tube cleaning], then press the [ENTER] key.**
 - The cap is filled with maintenance liquid.



- Close the cover. The cap cannot be filled with maintenance liquid while the cover is open. This is also true if the maintenance liquid cartridge is empty.

3 Open the maintenance cover on the right side.

- (1) Remove the two screws at the bottom of the right maintenance cover.
- (2) Hold the bottom edge of the maintenance cover, then pull out and forward to remove.

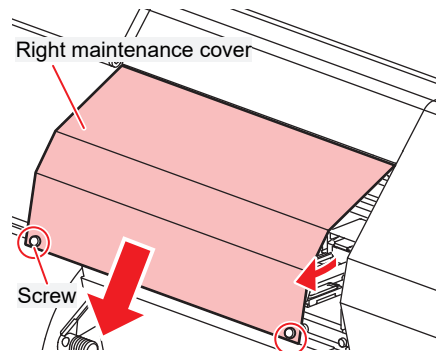

- Check to confirm that there is approximately half a capful of maintenance liquid inside.



- If not, use a syringe to draw up some maintenance liquid and drip in approximately half a capful.

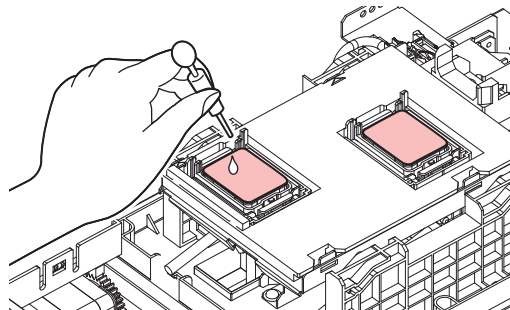

4 Close the maintenance cover, then press the [ENTER] key.

- Pump tube (ink discharge channel below the cap) washing starts.

Media Sensor Cleaning

Media sensors are located on the rear pre covers (2 locations) and carriage underside. The media cannot be detected correctly if dust or debris accumulates on the sensors. Remove any debris using cotton swabs or a soft cloth.

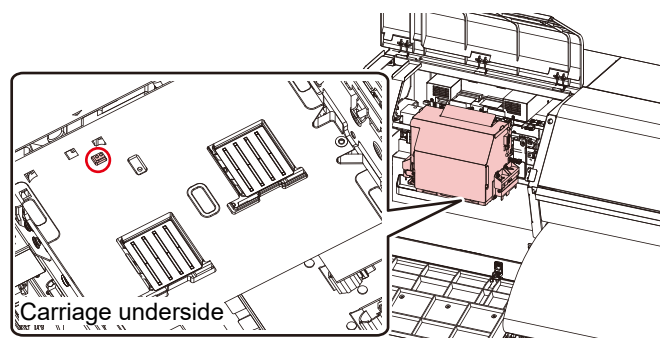
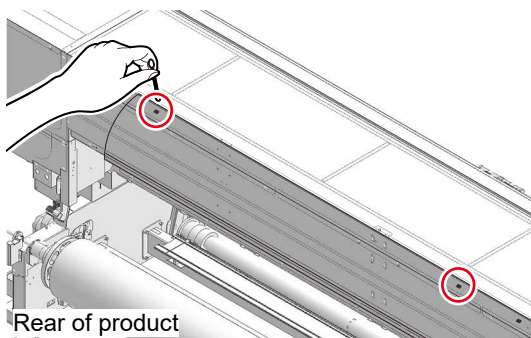

● Cleaning the carriage underside sensor

- 1 On the LOCAL mode screen, select [MENU] > [Maintenance], then press the [ENTER] key.
 - The Maintenance menu is displayed.

- 2 Select [Station Maint.] > [Carriage Out] > [Move To Maint. Space], then press the [ENTER] key.
 - The carriage moves to the maintenance space.
- 3 Open the maintenance cover on the left side.
 - (1) Remove the three screws at the bottom of the maintenance cover.
 - (2) Hold the bottom edge of the maintenance cover, then push on the area circled in blue and pull out and forward to remove.

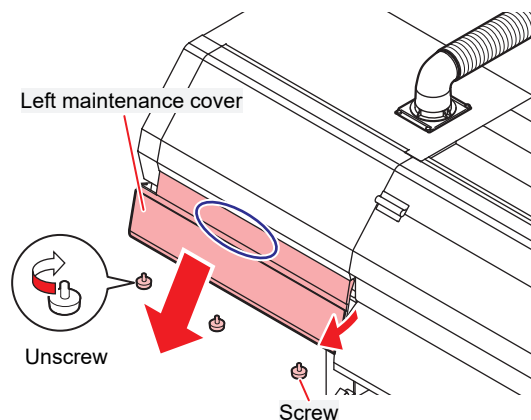

- 4 Clean the media sensor.
- 5 Once cleaning is complete, close the cover, then press the [ENTER] key.

Media Holder and Cloth Holder Cleaning

Continuing to use the dirty platen will prevent proper feeding of the media. It will also cause dried ink and attached dust to rub against the head nozzle surface and lead to ejection failures (e.g., nozzle clogging or deflection).

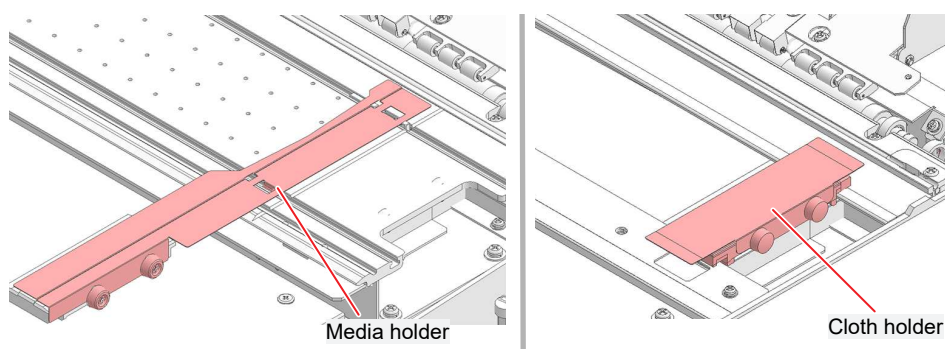

- Turn off the main power supply and unplug the power cable before carrying out maintenance.



- Be careful to prevent liquids from getting inside the machine. Otherwise there is a risk of failure, electric shock, or fire.



- For heavy soiling, wipe using a soft cloth soaked in diluted neutral detergent and thoroughly wrung out.



- Do not use organic solvents such as acetone and IPA. Doing so may damage the machine.

Jam Sensor Detecting Plate Cleaning

Continuing to use the dirty carriage underside will rub dried ink and attached dust on to the media, resulting in contaminated prints.

- 1** On the **LOCAL** mode screen, select **[MENU] > [Maintenance]**, then press the **[ENTER]** key.
 - The Maintenance menu is displayed.
- 2** Select **[Station Maint.] > [Carriage Out] > [Move To Maint. Space]**, then press the **[ENTER]** key.
 - The carriage moves to the maintenance space.
- 3** Open the maintenance cover on the left side.
 - (1) Remove the three screws at the bottom of the maintenance cover.
 - (2) Hold the bottom edge of the maintenance cover, then push on the area circled in blue and pull out and forward to remove.

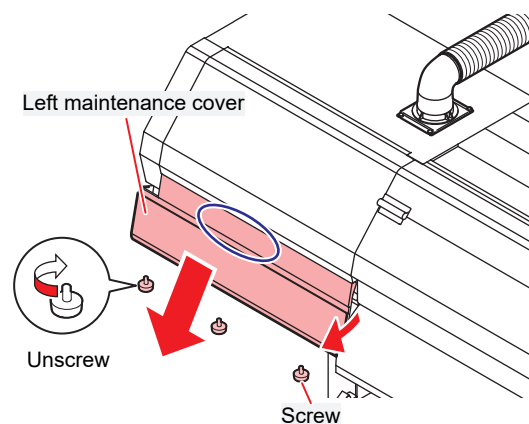

4 Clean the jam sensor detecting plate.

- Clean the jam sensor detecting plate underside at the left and right sides of the carriage.
- Wipe off any ink and dust adhering using a cleaning stick moistened with maintenance liquid. Wipe off the maintenance liquid. Make sure none remains.

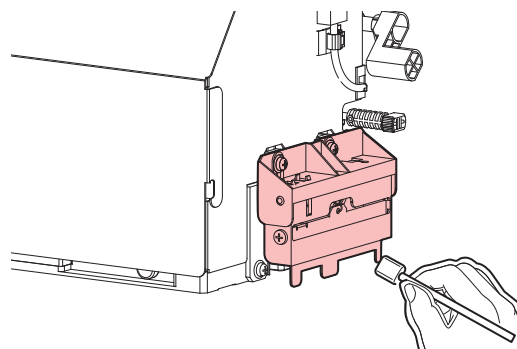

- 5** Once cleaning is complete, close the cover, then press the **[ENTER]** key.

Platen and Platen Wire Cleaning

Continuing to use the dirty platen will prevent proper feeding of the media. It will also cause dried ink and attached dust to rub against the head nozzle surface and lead to ejection failures (e.g., nozzle clogging or deflection).

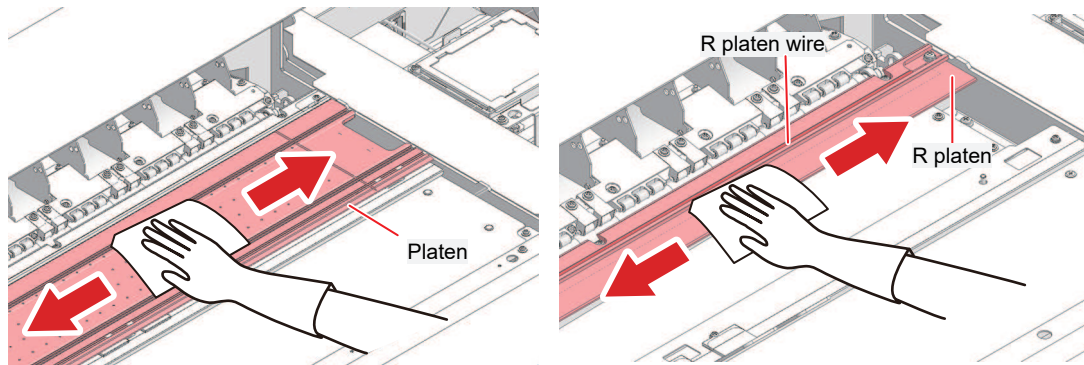

- Turn off the main power supply and unplug the power cable before carrying out maintenance.



- Be careful to prevent liquids from getting inside the machine. Otherwise there is a risk of failure, electric shock, or fire.
- **Do not pour water directly over the platens.**



- The grooves in which the media holder slides and the media is cut are susceptible to dust accumulation. Remove any debris carefully.



- For heavy soiling, wipe using a soft cloth soaked in diluted neutral detergent and thoroughly wrung out.



- Do not use organic solvents such as acetone and IPA. Doing so may damage the machine.

Pinch Roller and Grit Roller Cleaning

Continuing to use the dirty platen will prevent proper feeding of the media. It will also cause dried ink and attached dust to rub against the head nozzle surface and lead to ejection failures (e.g., nozzle clogging or deflection).

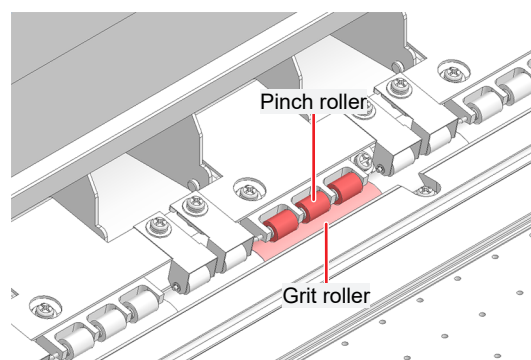

- Turn off the main power supply and unplug the power cable before carrying out maintenance.



- Be careful to prevent liquids from getting inside the machine. Otherwise there is a risk of failure, electric shock, or fire.



- Do not use organic solvents such as acetone and IPA. Doing so may damage the machine.

● For grit rollers

- 1 Open the front cover.
- 2 Raise the clamp lever.
- 3 Remove any dirt from the grit rollers by gently brushing several times with a plastic brush.
 - Brush the entire circumference by rotating the right-hand side of the grit rollers with your fingers.

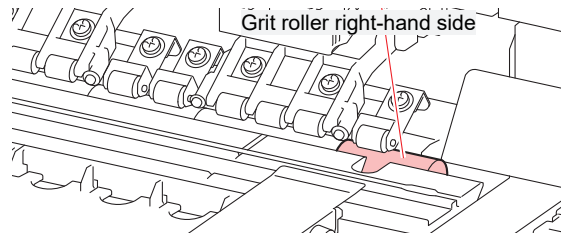

- Wipe the ends of the dirt brush clean with a dry cloth.
- If the dirt resists removal, wet the brush with water.



- Be sure to use a plastic brush to clean the grit rollers. Wiping with cloth or paper towels will result in fibers catching and adhering to the rough surfaces. Using a wire brush will damage the grit rollers and prevent correct feeding.
- After brushing with water, feed a piece of scrap media through to remove any moisture.

● For pinch rollers

Use a cloth to remove any ink or other dirt from the pinch roller surfaces.



- For heavy soiling, wipe using a soft cloth soaked in diluted neutral detergent and thoroughly wrung out.

Tension Roller Cleaning

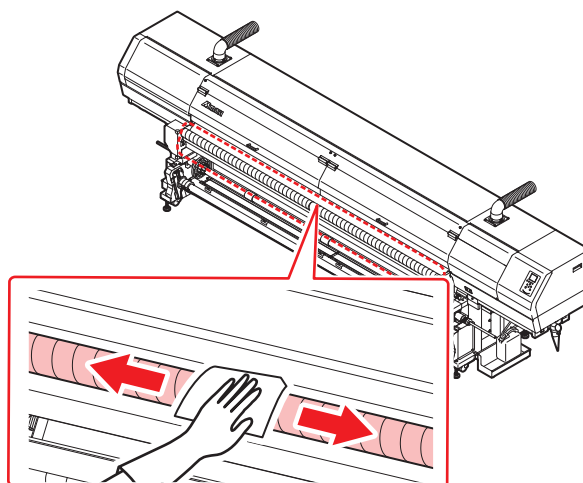

- For heavy soiling, wipe using a soft cloth soaked in diluted neutral detergent and thoroughly wrung out.

Cover (Exterior) Cleaning

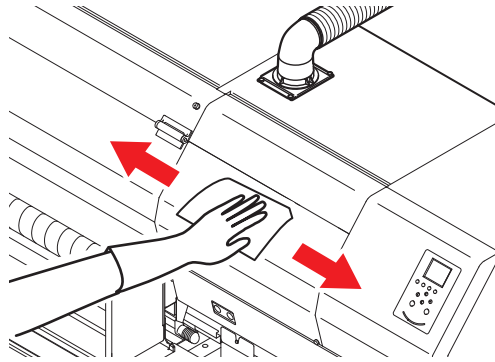

- Be careful to prevent liquids from getting inside the machine. Otherwise there is a risk of failure, electric shock, or fire.



- For heavy soiling, wipe using a soft cloth soaked in diluted neutral detergent and thoroughly wrung out.

When this Printer is Left Unused for a Long Time

Clean as follows if the product is not used for one week or longer:

Check beforehand

Is [Near End] or [Ink End] displayed?

- Maintenance liquid and ink is aspirated during the washing operation. Washing is not possible if an error occurs during this process. Replace with new ink.



- Do not turn off the main power supply. Turning off the main power supply will disable the automatic maintenance function (including nozzle clogging prevention function and ink discharge channel cleaning function). This increases the risk of ejection failures (such as nozzle clogging or deflection).

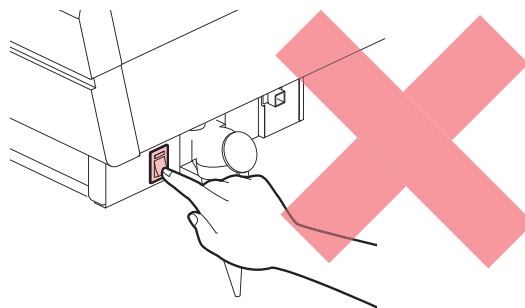

- Do not leave media loaded on the platen. This may leave irregularities or ripples in the media.



When the machine is not in use, raise the clamp lever to **separate the pinch rollers from the grit rollers**.

- Leaving the pinch rollers lowered may cause them to become deformed and prevent media from being fed correctly.
- Leaving media loaded will subject it to force from the pinch rollers, which may leave pinch roller marks on it.



- Dispose of the ink in the waste ink tanks located on the left and right sides of the machine.
 ["Waste Ink Tank Replacement"\(P. 156\)](#)



- Clean the flushing unit. "Flushing Unit Cleaning"(P. 124)

- 1 On the LOCAL mode screen, select [MENU] > [Maintenance], then press the [ENTER] key.**
 - The Maintenance menu is displayed.
- 2 Select [Station Maint.] > [Custody Wash], then press the [ENTER] key.**
 - The carriage moves over the platen.
- 3 Open the maintenance cover on the right side.**
- 4 Clean the cap rubber.**
 - "Cap Rubber Cleaning"(P. 120)
- 5 Once cleaning is complete, close the cover, then press the [ENTER] key.**
 - The cap is filled with maintenance liquid.



- Close the cover. The cap cannot be filled with maintenance liquid while the cover is open. This is also true if the maintenance liquid cartridge is empty.

- 6 Open the maintenance cover on the right side.**
 - (1) Remove the two screws at the bottom of the right maintenance cover.
 - (2) Hold the bottom edge of the maintenance cover, then pull out and forward to remove.

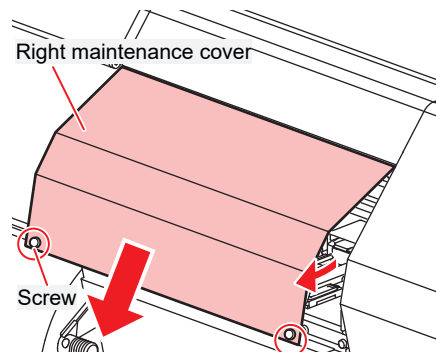

- Check to confirm that the cap is filled with maintenance liquid.



- If not, use a syringe to draw up some maintenance liquid and fill until it almost overflows from the cap.

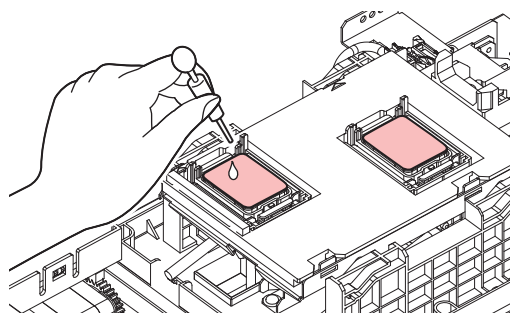

- 7 Close the maintenance covers.**

8 Set the exposure time, then press the [ENTER] key.

- Cleaning is performed automatically once print nozzle washing has ended.
- The cap is filled with maintenance liquid.

9 Open the maintenance cover on the right side.

- Check to confirm that there is approximately half a capful of maintenance liquid inside.



- If not, use a syringe to draw up some maintenance liquid and drip in approximately half a capful.

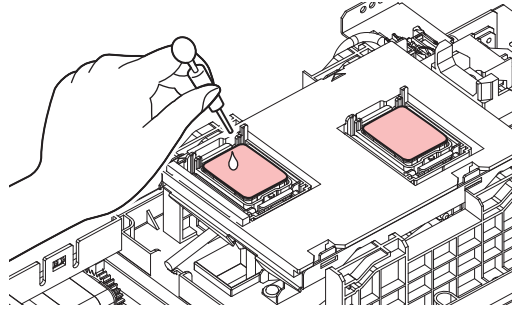

10 Close the maintenance cover, then press the [ENTER] key.

- Pump tube (ink discharge channel below the cap) washing starts.

4.3 Replacement of Consumable Item

To order replacement consumable items, contact your local dealer or our service office. For more information on consumable items, refer to our website (<https://mimaki.com/supply/inkjet.html>).



- Do not store consumable items in locations where children may enter.



- When disposing of consumable items, contact an industrial waste disposal operator or dispose of the product in accordance with the local laws and regulations.

Consumable Item Replacement Timing

Timing	Item
When dirty	<ul style="list-style-type: none"> "Replacing the Absorber Around the Station"(P. 141) "Exhaust Fan Filter Replacement"(P. 144) "Flushing Unit Absorber Pad Replacement"(P. 145) "Wiper Replacement"(P. 136)
When ejection failures cannot be remedied	<ul style="list-style-type: none"> "Cap Replacement"(P. 139) "Wiper Replacement"(P. 136)
When damaged	<ul style="list-style-type: none"> "Wiper Replacement"(P. 136) "Cap Replacement"(P. 139) "Pinch Roller Replacement"(P. 148) "Media Holder and Cloth Holder Replacement"(P. 149)
When replacing ink	<ul style="list-style-type: none"> "Ink Supply Unit Ink Absorber Replacement"(P. 155)
When "Replace Wiper" appears on the display	<ul style="list-style-type: none"> "Wiper Replacement"(P. 136)
When "Check Waste Ink Tank" appears on the display	<ul style="list-style-type: none"> "Waste Ink Tank Replacement"(P. 156)
Once a year	<ul style="list-style-type: none"> "Wiper Cleaner Replacement"(P. 137)

Wiper Replacement

The machine maintains a count of the number of wiping cycles. The "Replace Wiper" message appears when a preset count is reached. Replace dirty or warped wipers with new ones.

The wiper used will vary depending on the print head height.

Range	Wiper type
Low (recommended)	Wiper kit (SPC-0843/Rubber color: Blue)
Middle	
High	HiGap wiper kit (SPC-0850/Rubber color: Black)

- 1** "Replace Wiper" appears on the display.
- 2** On the LOCAL mode screen, select [MENU] > [Maintenance], then press the [ENTER] key.
 - The Maintenance menu is displayed.
- 3** Select [Station Maint.] > [Replace Wiper], then press the [ENTER] key.
 - The carriage moves over the platen.
- 4** Open the maintenance cover on the right side.
 - (1) Remove the two screws at the bottom of the right maintenance cover.
 - (2) Hold the bottom edge of the maintenance cover, then pull out and forward to remove.

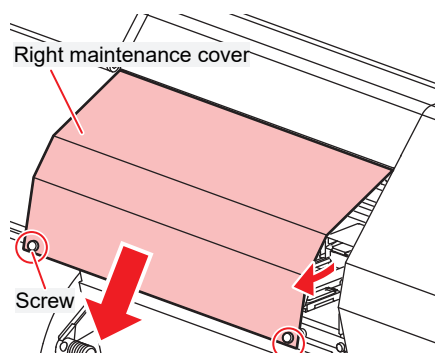

- 5** Remove the wiper.
 - Hold the lug at the rear of the wiper bracket, then pull out the wiper.

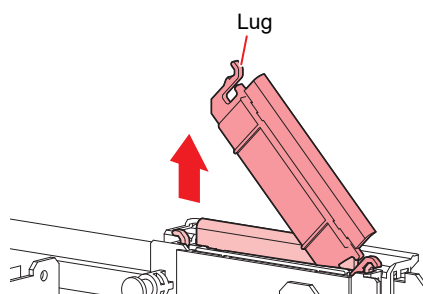

6 Clean the wiper slider.

- Wipe off any ink and dust adhering using a cleaning stick moistened with maintenance liquid. Wipe off the maintenance liquid. Make sure none remains.

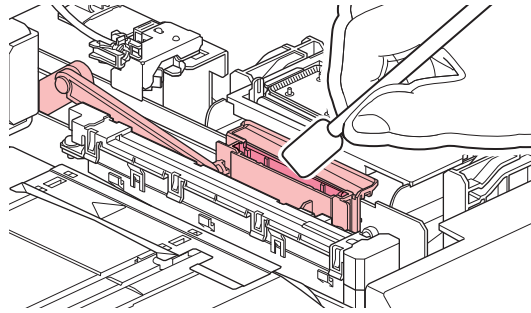

7 Mount a new wiper.

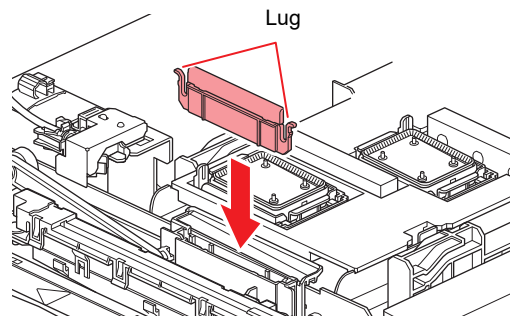

8 Once replacement is complete, close the cover, then press the [ENTER] key.

- The wiper usage count is reset.

Wiper Cleaner Replacement

Replace with a new wiper cleaner (SPC-0243) once a year.

1 On the LOCAL mode screen, select [MENU] > [Maintenance], then press the [ENTER] key.

- The Maintenance menu is displayed.

2 Select [Station Maint.] > [Carriage Out] > [Move To Platen Right End], then press the [ENTER] key.

- The carriage moves over the platen.

3 Open the maintenance cover on the right side.

- (1) Remove the two screws at the bottom of the right maintenance cover.
- (2) Hold the bottom edge of the maintenance cover, then pull out and forward to remove.

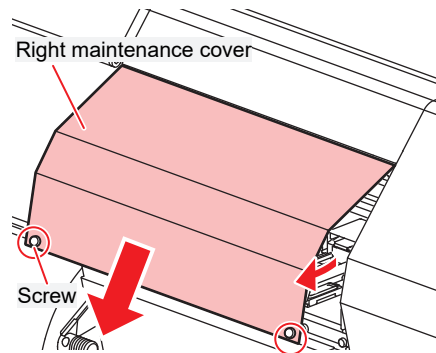

4 Remove the fitting.

- Hold the lugs on the fitting, then pull off.
- Take care to avoid losing the rubber seal.

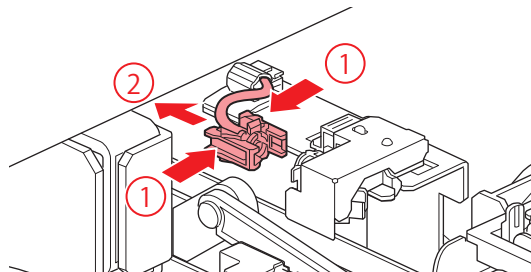

5 Remove the wiper cleaner.

- Slide forward to remove.

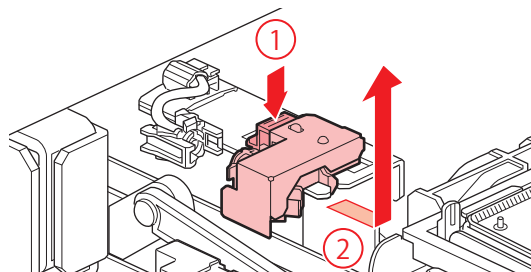

6 Mount a new wiper cleaner.

- Slide to the rear to attach it.

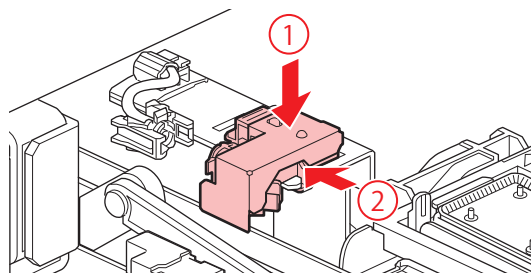

7 Reattach the fitting.

- Improper attachment may result in leaking maintenance solution.

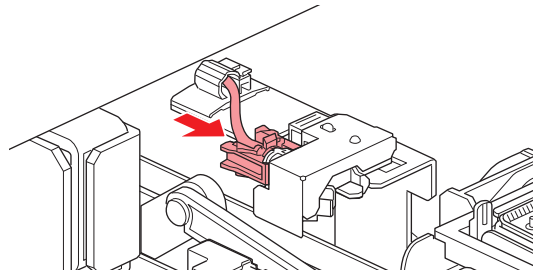

8 Once replacement is complete, close the cover, then press the [ENTER] key.

Cap Replacement

If ejection failures (e.g., nozzle clogging or deflection) remain unresolved even after cleaning, replace with a new cap.



- Be sure to replace the cap if you observe any scratches or other damage on the rim.



- The cap surface is susceptible to drying out, which can lead to path clogging. If this occurs, either replace the cap or remove and wash it.



- We recommend replacing the cap every six to twelve months.

1 On the LOCAL mode screen, select [MENU] > [Maintenance], then press the [ENTER] key.

- The Maintenance menu is displayed.

2 Select [Station Maint.] > [Replace Cap], then press the [ENTER] key.

- The carriage moves over the platen.

3 Open the maintenance cover on the right side.

- (1) Remove the two screws at the bottom of the right maintenance cover.
- (2) Hold the bottom edge of the maintenance cover, then pull out and forward to remove.

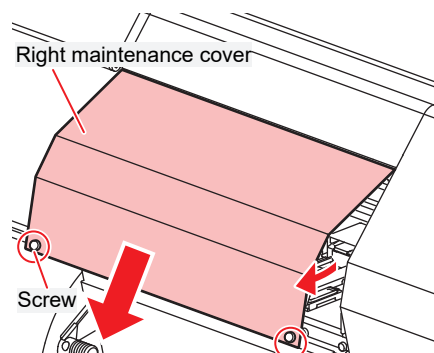

4 Remove the cap.

- Squeeze the lugs on either side of the cap and pull off.

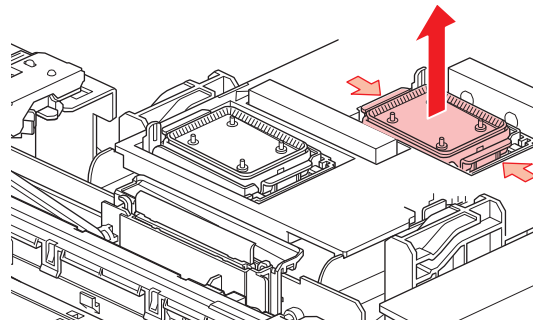

5 Rinse the cap with the mesh side facing downward in a container filled with maintenance liquid. Remove, then wipe clean the resin part thoroughly.

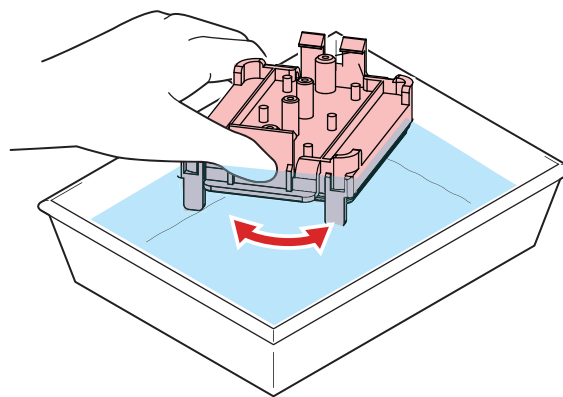

6 Apply maintenance liquid.

- Use a syringe to apply two or three drops of maintenance liquid to the hole at the front.

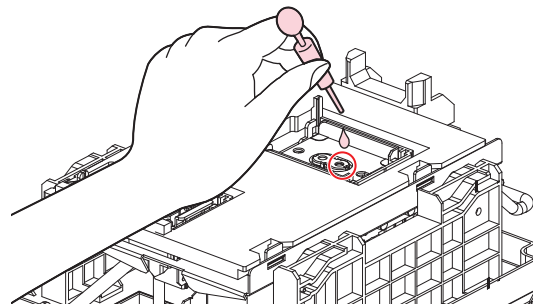

7 Mount a new cap or a cap that has been washed.

- Position with the slot at the front and push in until it clicks.

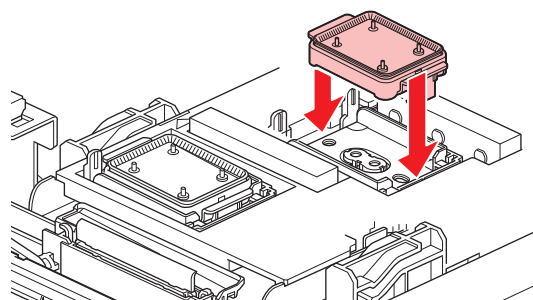

- 8** Once replacement is complete, close the cover, then press the [ENTER] key.

Replacing the Absorber Around the Station

If the cap absorber or maintenance liquid absorber is very dirty or if ink drips on to the media, replace with a new cap absorber.

- 1** On the LOCAL mode screen, select [MENU] > [Maintenance], then press the [ENTER] key.
 - The Maintenance menu is displayed.
- 2** Select [Station Maint.] > [Carriage Out] > [Move To Platen Right End], then press the [ENTER] key.
 - The carriage moves over the platen.
- 3** Open the maintenance cover on the right side.
 - (1) Remove the two screws at the bottom of the right maintenance cover.
 - (2) Hold the bottom edge of the maintenance cover, then pull out and forward to remove.

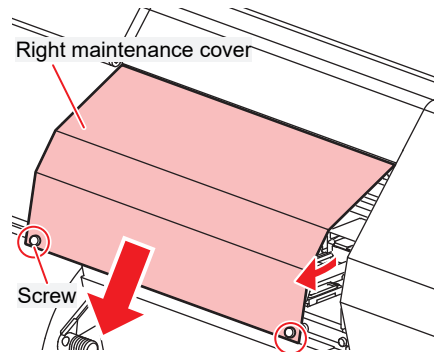

- 4** Remove the two screws, then remove the cap cover.
 - Slide to the rear to detach the tabs at the front.

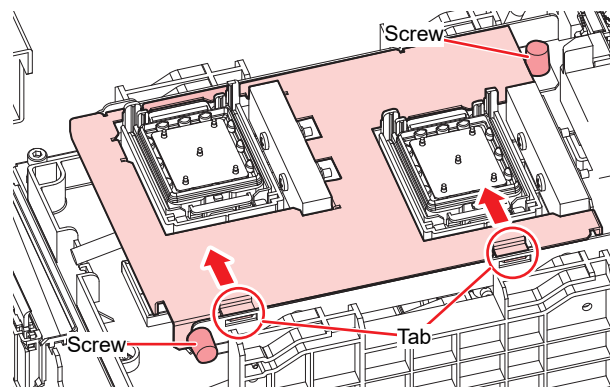

5 Remove the cap absorbers from the cap cover.

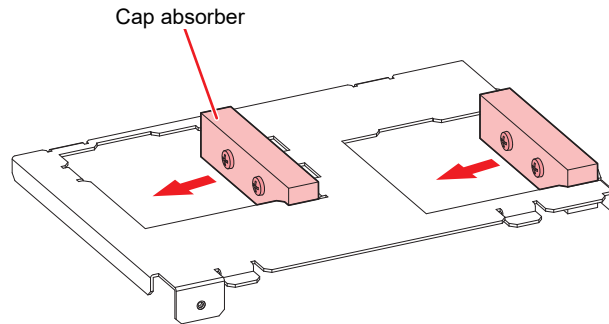

- Avoid ink dripping when removing the cap absorbers.

6 Mount new cap absorbers in the cap cover.

- Push firmly on to the protrusion.

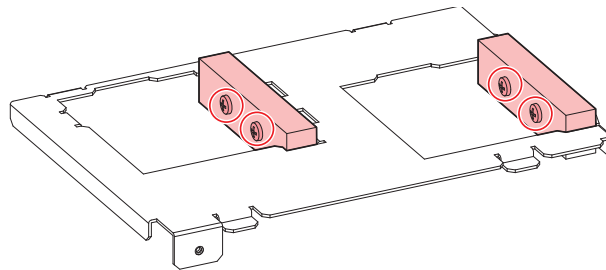

7 Clean the cap base.

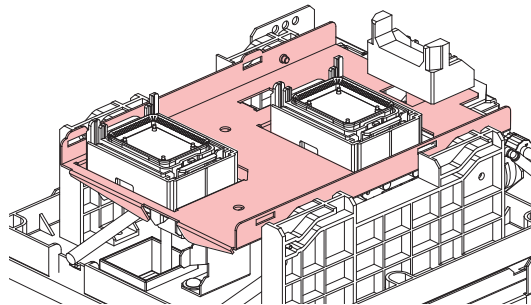

8 Mount the cap cover.

- Push the tabs on the cap cover into the slits at the rear of the slider, then insert the tabs at the front.

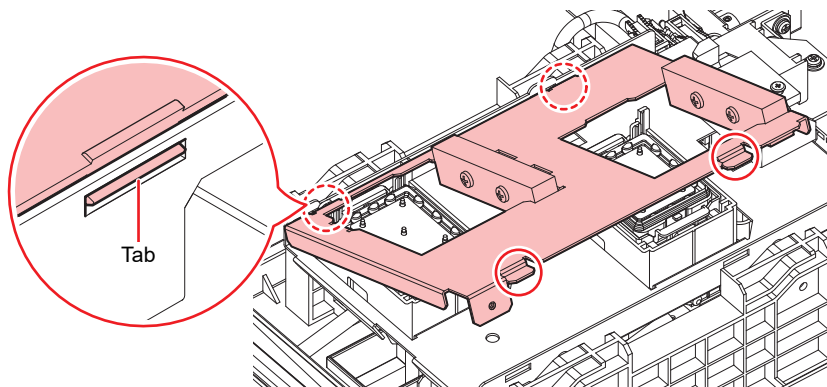

9 Insert the two screws to secure the cap cover in place.

10 Remove the maintenance liquid absorber.

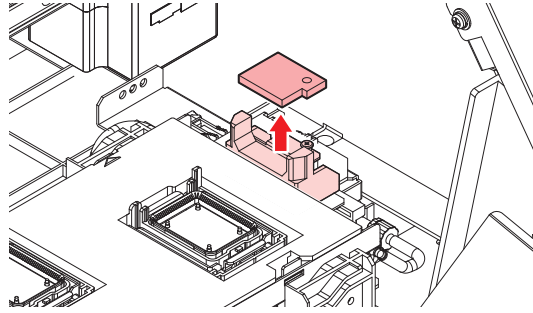

11 Wipe away any maintenance liquid from around the slider block.

12 Mount a new maintenance liquid absorber.

- Push firmly on to the protrusion.

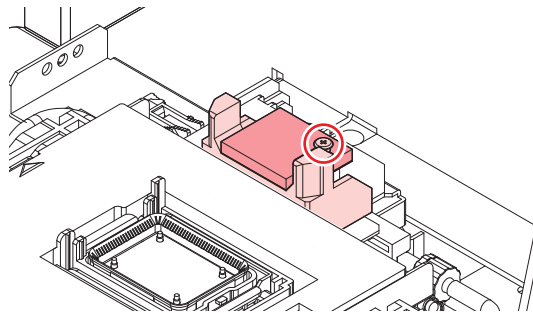

13 Check to confirm that the absorber is not lifting or curved.

14 Once replacement is complete, manually push the wiper back to the rear.

15 Close the maintenance cover, then turn on the power.

- Confirm that the carriage returns to the station.

Exhaust Fan Filter Replacement

Check the exhaust fan filter condition. Replace if very dirty.

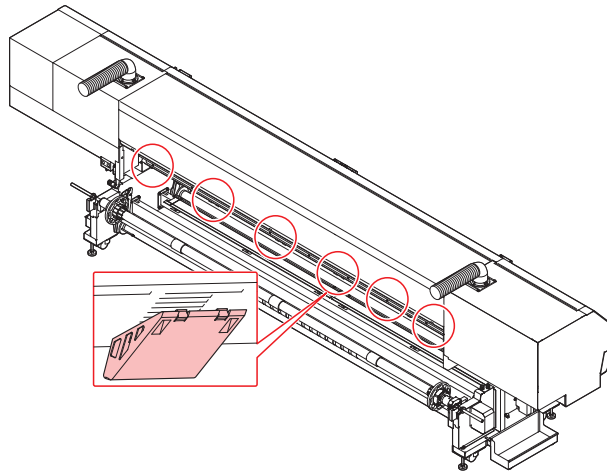

1 Remove the exhaust fan box.

- Push the tabs at the front to remove the exhaust fan box.

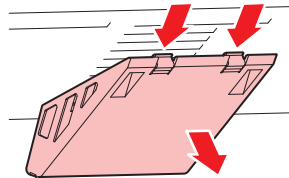

- Replace the very dirty exhaust fan box with new one.

2 Mount a new exhaust fan filter in the exhaust fan box.

- Press the exhaust fan filter into the space under the tabs of the exhaust fan box.

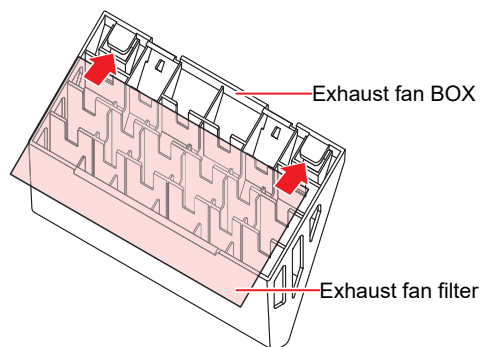

3 Mount the exhaust fan box.

- Insert the tabs of the exhaust fan box into the slits of the machine, and clip in the tabs at the front.

Flushing Unit Absorber Pad Replacement

Replace the absorber pads on the flushing units (one each on the left and right) with new ones if they are particularly dirty.

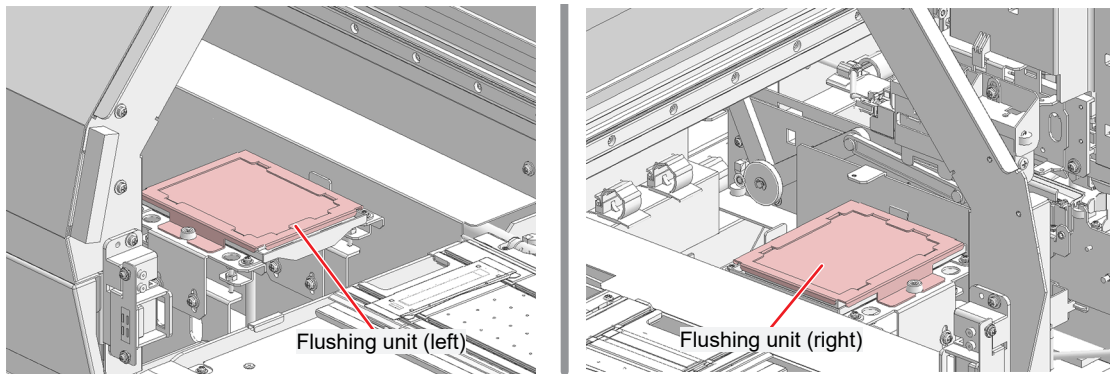

Code	Item
SPC-0813	Flushing box absorber pad replacement kit



- Cut the sponge (absorber pad) provided in the flushing box absorber pad replacement kit to a size of 105 mm × 78 mm for use.



- Turn off the main power and unplug the power cable before replacement.

1 Open the left and right maintenance covers.

- (1) Remove the three screws at the bottom of the left maintenance cover.
- (2) Hold the bottom edge of the maintenance cover, then push on the area circled in blue and pull out and forward to remove.

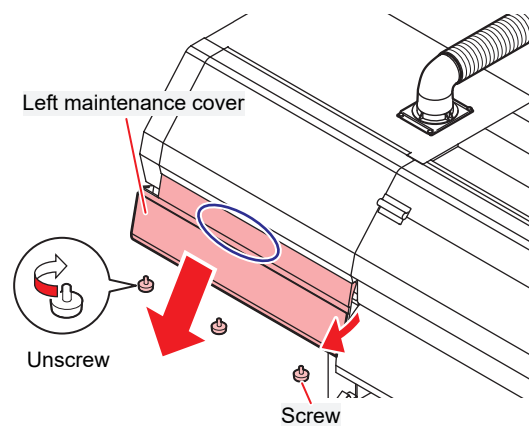

- (1) Remove the two screws at the bottom of the right maintenance cover.
- (2) Hold the bottom edge of the maintenance cover, then pull out and forward to remove.

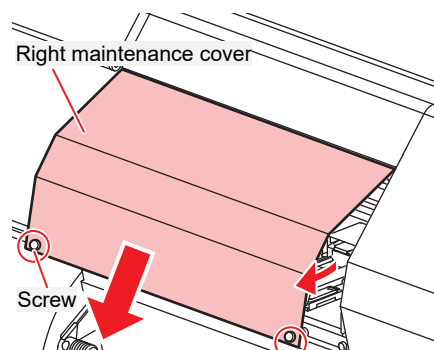

- 2** Remove the flushing cover together with the flushing mesh and flushing absorber pad. (Screw x1)

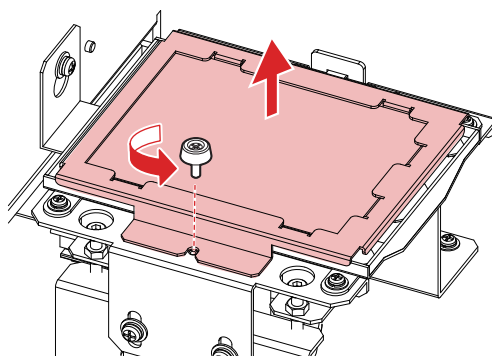

- 3** Detach the flushing mesh and flushing absorber pad from the flushing cover.

- Slide the flushing mesh in the direction indicated by the arrow in the figure to remove it.
- Pull the flushing absorber pad downward to remove it.

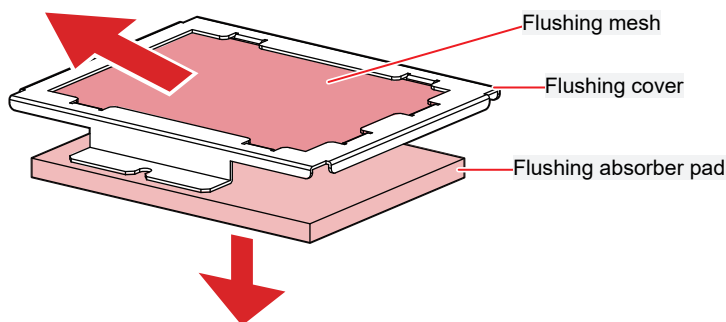

- Avoid ink dripping when removing the absorber pad.

- 4** Reinstall the flushing mesh into the flushing cover by sliding it in the opposite direction to when it was removed.

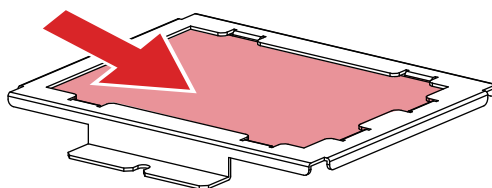

- 5** Install a new flushing absorber pad in the flushing cover. (Claws x6)

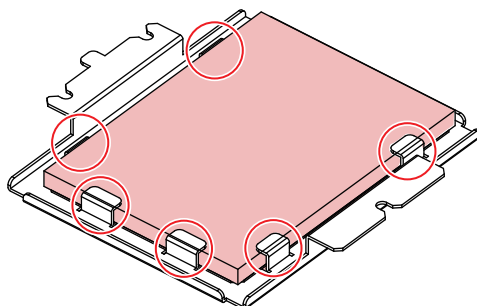

- 6** Secure the flushing cover with the flushing absorber pad fitted to the flushing ink-receiving pan. (Screw ×1)

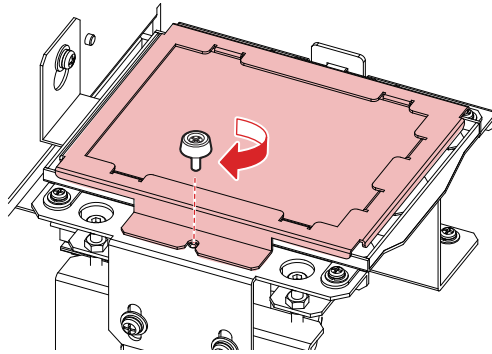

Pinch Roller Replacement

Replace worn or dirty pinch rollers with new ones.



- Turn off the main power and unplug the power cable before replacement.

- 1 Open the front cover.
- 2 Raise the clamp lever.
- 3 Remove along with the clamp holder. (Screw ×1)

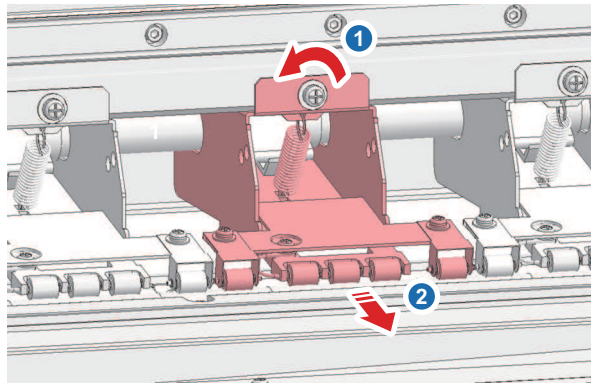

- 4 Remove the pinch roller spindle.
 - (1) Remove the two screws.
 - (2) Remove the screw.
 - (3) Remove the pinch roller spindle.

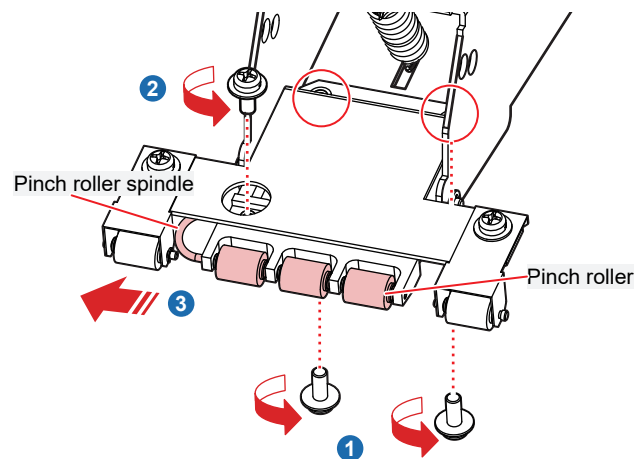

- 5 Mount the new pinch rollers, and return the unit in the reverse procedure to above.
- 6 Secure the clamp holder.
- 7 Close the front cover.

Media Holder and Cloth Holder Replacement

If the media holders or cloth holders become deformed and touch the carriage or print head, replace with new media holders or cloth holders.

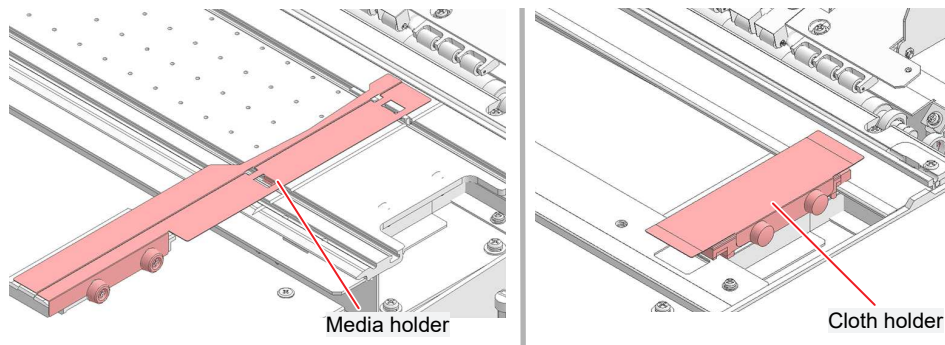

- Turn off the main power and unplug the power cable before replacement.

● For media holders

This is the procedure for replacing the left-hand media holder. Replace the right-hand media holder in the same way.

1 Open the front cover.

2 Lift up the removable platens.

- The removable platens are firmly secured with magnets. Lift up as follows:
 - (1) Insert the two platen removal jigs provided between the main unit and removable platens.
[Platen removal jig insertion positions]

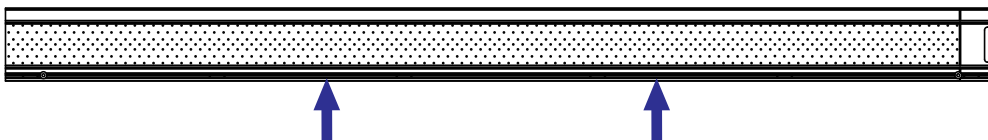

- (2) Push up the removable platens, then lift them up.

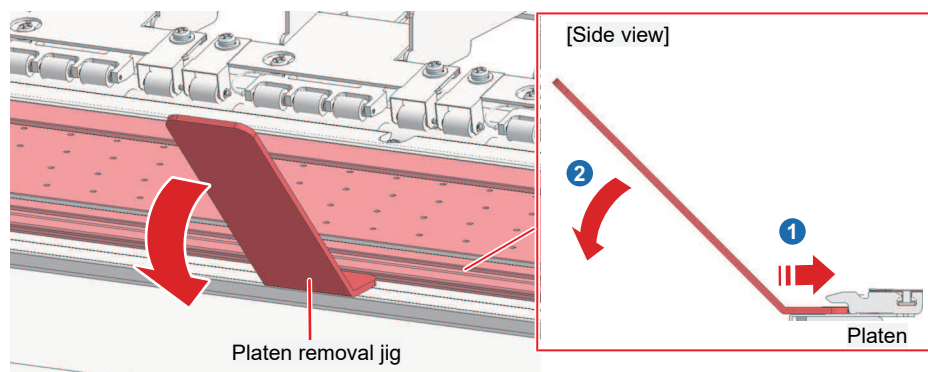

- Take care when lifting the platens, as they are secured with magnets, and may spring up.
- Do not use excessive force when inserting the platen removal jigs. Doing so may damage parts.

3 Pull the raised removable platens forward to detach them from the rear platens.

4 Remove the media holder from the platen.

- Push between the red circled areas and slide the left end to remove.

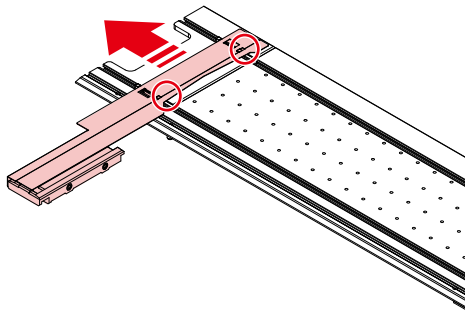

- Do not slide the media holder by holding the part protruding from the platen. The media holder may deform.

5 Remove the sliders and the cloth holder base (x 2screws) from the media holder.

- Be careful to avoid misplacing the sliders, the cloth holder base and screws.

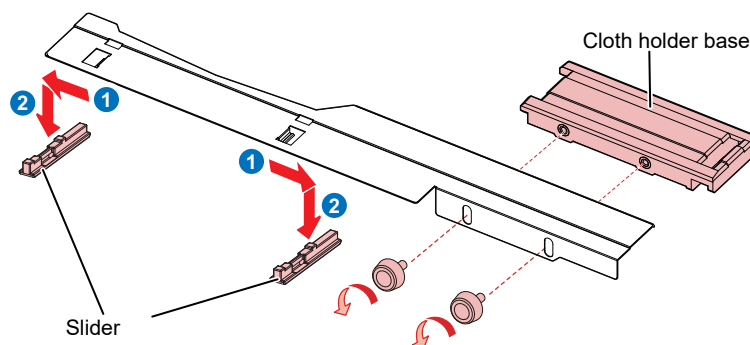

6 Mount the sliders and the cloth holder base (x 2screws) on to the new media holder.

- Engage the holes in the sliders on to the lugs on the media holder.

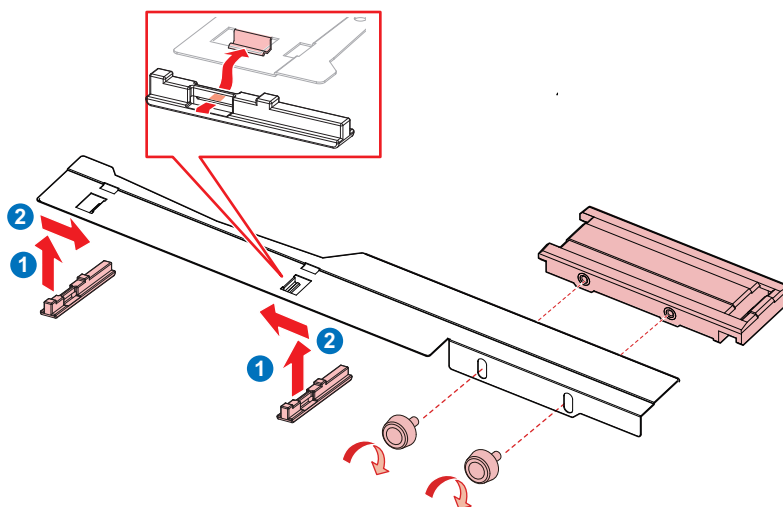

7 Mount the new media holder on to the platen.

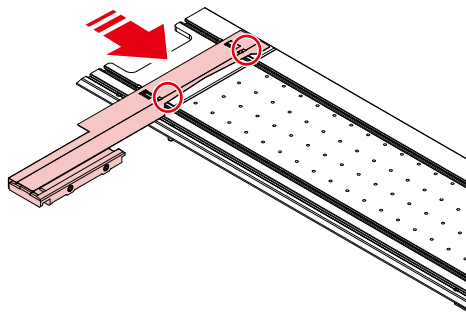

8 Push the removable platens L and R the rear platen, aligning the edges with the central groove, and securely engage the reference pins in the center into the holes in the ink guard F or platen frame.

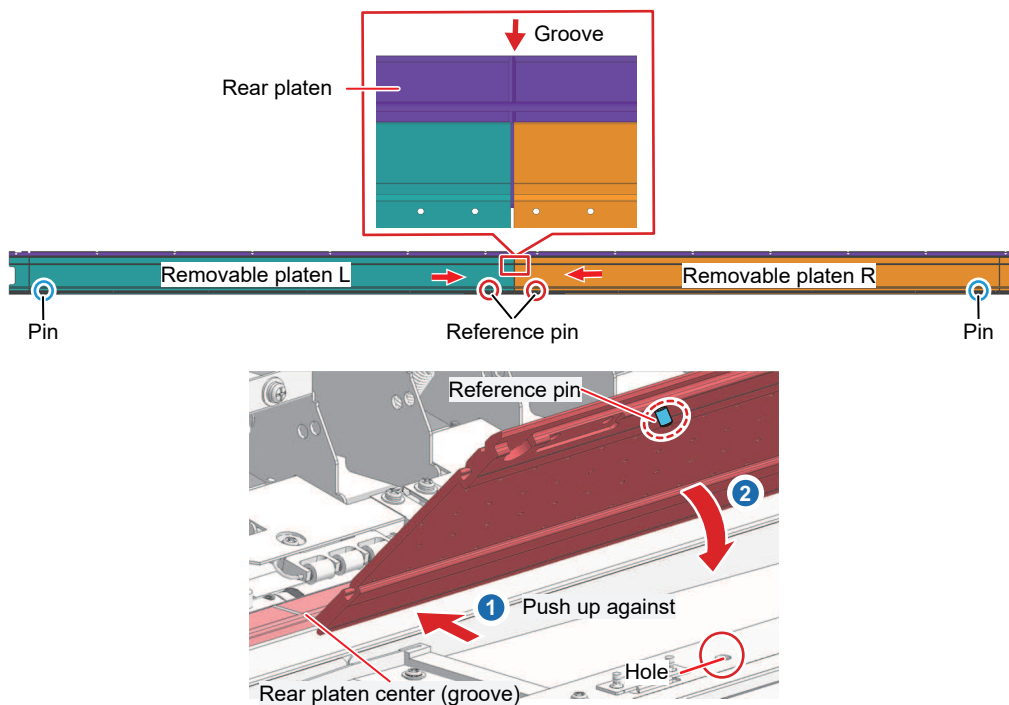

- Take care to ensure that no paper scraps or threads are trapped when pushing the platens up flush.
- Remove any paper scraps or threads before proceeding.



- Check to confirm that the removable platens are securely installed and do not lift up.
- Clean the removable platens after installation if they are dirty.  ["Platen and Platen Wire Cleaning"\(P. 130\)](#)



- Take care not to trap your fingers when attaching the removable platens, as the magnets are powerful.
- Attach the platen carefully so that the media holder does not get caught.

- 9** Loosen the media holder height adjuster screws (x2) and tighten the adjuster screws while the media holder is in contact with the platen F cover.

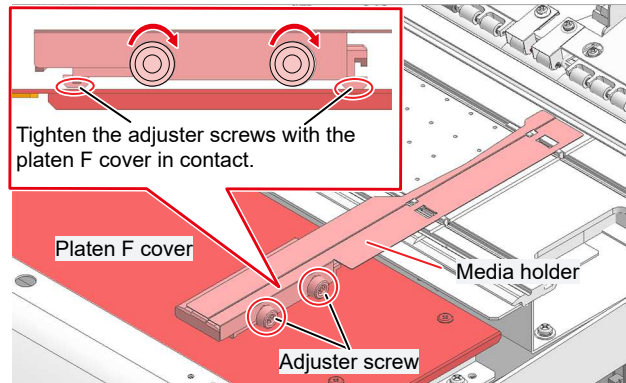

- 10** Close the front cover.

- For cloth holders

1 Open the left and right maintenance covers.

- (1) Remove the three screws at the bottom of the left maintenance cover.
- (2) Hold the bottom edge of the maintenance cover, then push on the area circled in blue and pull out and forward to remove.

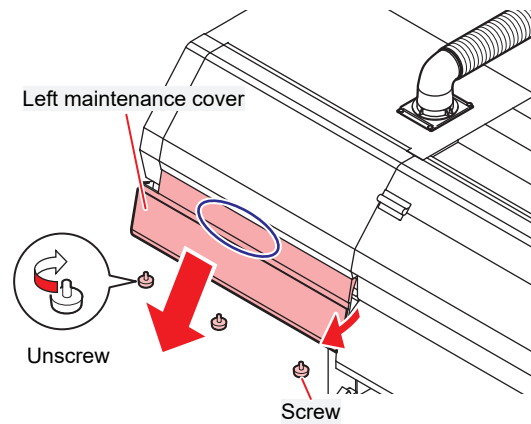

- (1) Remove the two screws at the bottom of the right maintenance cover.
- (2) Hold the bottom edge of the maintenance cover, then pull out and forward to remove.

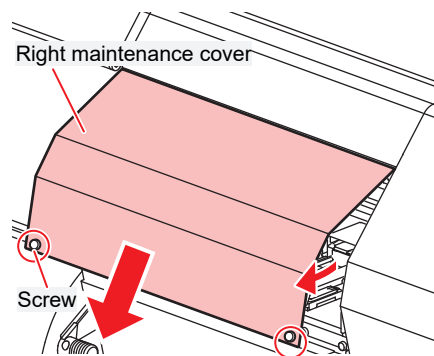

2 Remove the left and right cloth holders.

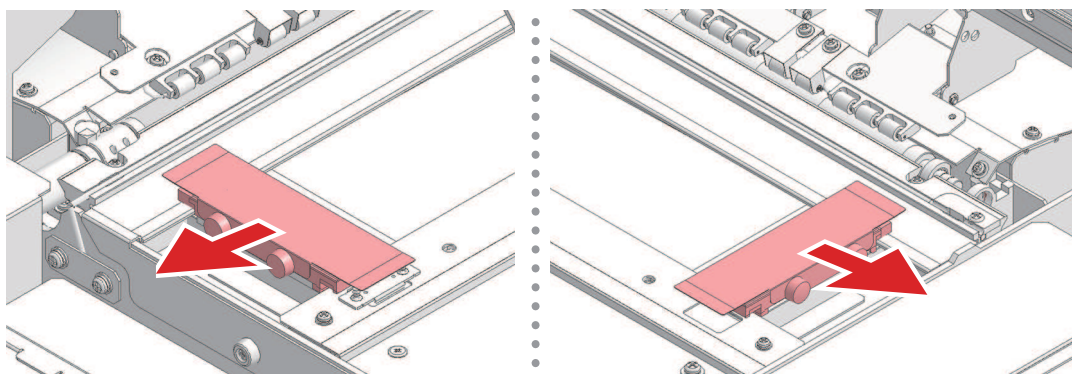



- Remove the cloth holders by moving them to the far edge of the rear platens, then lifting up toward you.

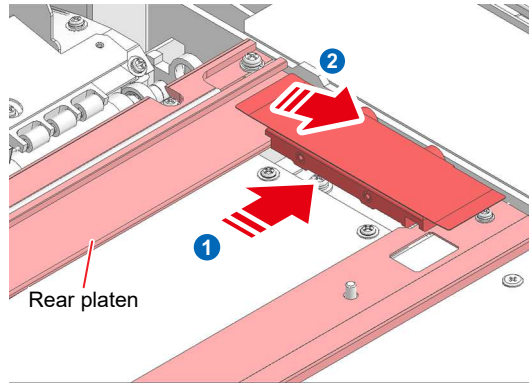

3 Mount new cloth holders.

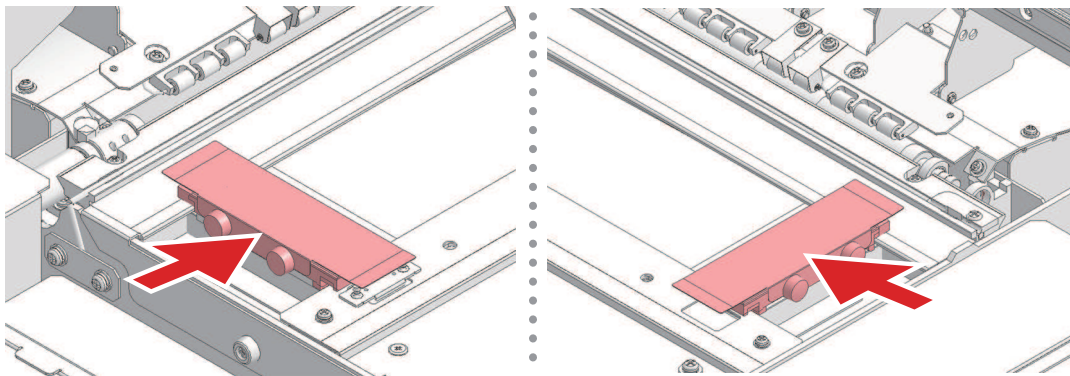

- Attach the cloth holders by first engaging the hook at the rear of the cloth holders on to the rear platen, and then sliding sideways.

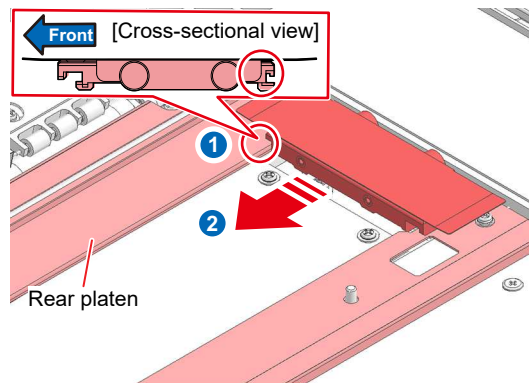

- Note the orientation of the left and right cloth holders. Attach so that the screws are facing outward. Note also that the cloth holders are shaped differently at the front and rear.

4 Close the maintenance covers.

Ink Supply Unit Ink Absorber Replacement

We recommend replacing the ink absorber each time you replace the ink pack, to prevent dirt building up on the pedestal of the ink supply unit.



- Pay close attention to ventilation and be sure to wear safety glasses, gloves, and a mask when handling ink, maintenance liquid, waste ink, or other solutions used with the machine. Leaking ink may adhere to the skin or get into the eyes or mouth.



- 1 Push down the lever on the pedestal, and remove the ink Eco-case.

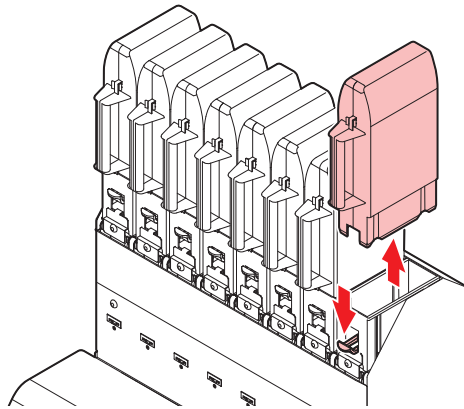

- 2 Remove the ink absorber, and replace with a new one.

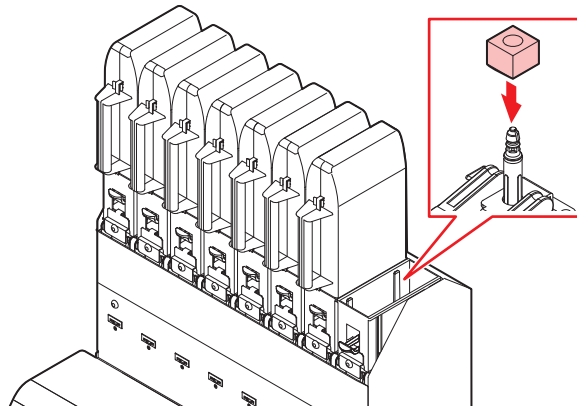

- 3 Set an eco-case on the base.

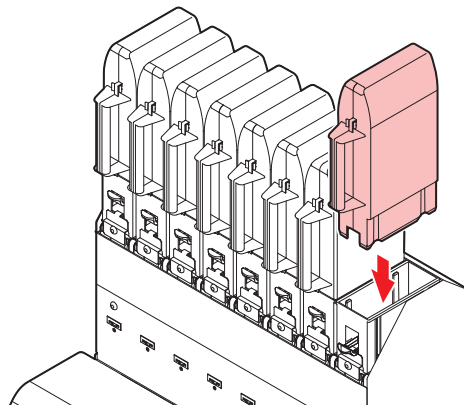

Waste Ink Tank Replacement

The ink used in printing and head cleaning is stored in the waste ink tanks on the right and left sides of the machine.



- Continuing to use the product without disposing of the waste ink may result in waste ink overflowing from the waste ink tank. Visually check ink levels in the waste ink tank about once a week.



- Pay close attention to ventilation and be sure to wear safety glasses, gloves, and a mask when handling ink, maintenance liquid, waste ink, or other solutions used with the machine. Leaking ink may adhere to the skin or get into the eyes or mouth.



When "Check Waste Ink Tank" message appears

- The "Check Waste Ink Tank" message appears on the display.



Check Waste Ink tank



- The message appears once every seven days.

Replacing the Waste Ink Tank

- Remove the waste ink tanks (one on each side).

- Remove the tubes inserted into the waste ink tanks, then remove the waste ink tanks.

Important!

- Ink may drip from the ends of the tubes when they are removed from the waste ink tanks. Wipe the tubes with a cloth, and wrap the ends before proceeding.

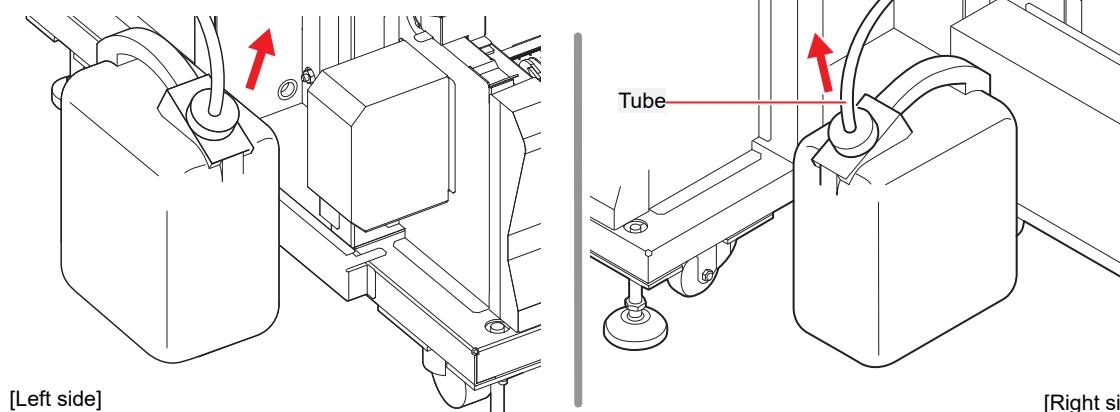

- Attach the cap to the removed waste ink tank, and use tape to prevent leakage of waste ink.



- When disposing of ink, maintenance liquid or other liquid used with the product, or the container or paper towel to which ink or other liquid is attached, contact an industrial waste disposal operator or dispose of the product in accordance with the local laws and regulations.

3 Insert the tubes into the two new waste ink tanks (two into the left tank and six into the right tank).

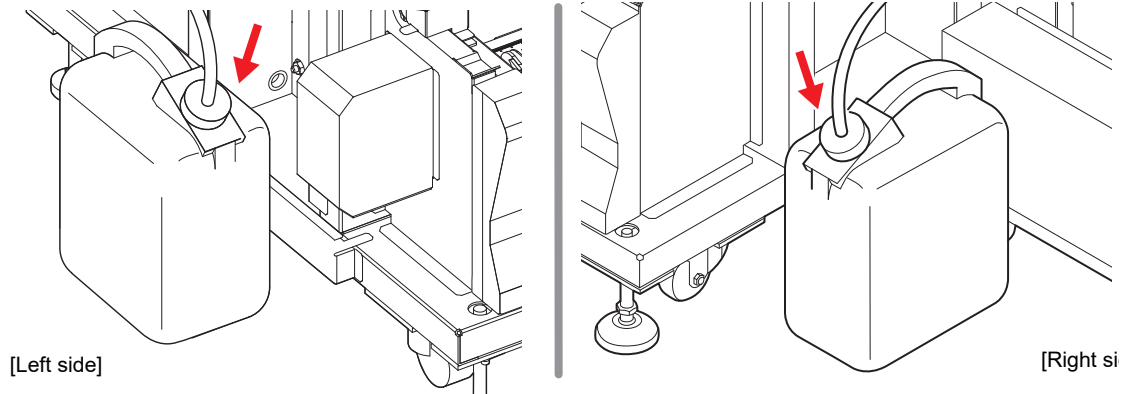

- Left side: Two tubes (one from the flushing unit, one from the ink groove ink-receiving pan)
- Right side: Six tubes (one from flushing unit, one from ink groove ink-receiving pan, two from suction pump, one from station, one from wiper)

4 Press the [ENTER] key.

Chapter 5 Troubleshooting



This chapter

This chapter describes corrective actions for troubleshooting and messages on the display.



Troubleshooting.....	160	The ink has leaked out.....	163
The power does not turn on.	160	Problems Causing Messages to Appear	164
Printing is not possible.	160	Warning Messages	164
The media jams or the media is dirty.	160	Ink error.....	165
Image defects occur.....	161	Error Message	166
The heater temperature does not rise to the specified value.	163	SYSTEM HALT	172

5.1 Troubleshooting





For information on troubleshooting, refer to this chapter. Refer to our website (<https://mimaki.com/support/>) for frequently asked questions (FAQs) about this product and customer support videos.

If the recommended corrective action does not resolve the problem, contact your local dealer or our service office.

The power does not turn on.

Points to check	Corrective action
Is the power cable connected to the machine?	Insert the power socket until it clicks into place.
Are you using the power cable provided?	Use the power cable provided.
Is the main power supply turned on?	Turn on the main power supply.  "Turning On the Power"(P. 34)
Is the [END/POWER] key on the operating panel turned on?	Turn the power on.  "Turning On the Power"(P. 34)

Printing is not possible.

Points to check	Corrective action
Is a USB interface cable connected?	Connect the cable securely to the USB 2.0 port.  "Using a USB Cable"(P. 37)
Is a LAN cable connected?	Connect the cable securely to the LAN port.  "Using a LAN Cable"(P. 36)
Are you using a LAN cable approved by Mimaki?	Check the LAN cable type.  "Using a LAN Cable"(P. 36)
Is the status lamp on the operating panel illuminated or flashing red?	An error has occurred. Check the message on the display.  "Operating Panel"(P. 30)

The media jams or the media is dirty.

Points to check	Corrective action
Are you using the recommended media?	Make sure you are using the recommended media. https://mimaki.com/supply/inkjet.html
Are you using curled media?	Do not use curled media or media with folded ends.
Is the media skewed?	Use the take-up unit to adjust the media or reload the media.  "Loading the Media"(P. 68)
Does the media have ripples/surface irregularities or lift up?	If you are using roll media, use a smooth section of the media for initial feeding. For more information, refer to the description on transporting media on the platen. https://mimaki.com/download/inkjet.html

Image defects occur.

Symptom	Corrective action
White streaks, blurriness, and dark streaks occur. (Carriage scan direction)	<ol style="list-style-type: none"> 1. Remove any paper scraps or other debris adhering to areas over which the head passes (e.g., media holders). ☞ "Media Holder and Cloth Holder Cleaning"(P. 128) ☞ "Platen and Platen Wire Cleaning"(P. 130) 2. Perform the procedure described in ☞ "Head Cleaning"(P. 93). 3. Perform the procedure described in ☞ "Feed Correction"(P. 94). 4. Perform the procedure described in ☞ "Cap Rubber Cleaning"(P. 120). 5. Perform the procedure described in ☞ "Carriage Underside Cleaning"(P. 121).
Text is double- or triple-printed in the media feed direction.	<ol style="list-style-type: none"> 1. Perform the procedure described in ☞ "Feed Correction"(P. 94).
Offsetting occurs during bidirectional printing.	<ol style="list-style-type: none"> 1. Perform the procedure described in ☞ "Correcting the Drop Position"(P. 96).
Ink droplets drip during printing.	<ol style="list-style-type: none"> 1. Perform the procedure described in ☞ "Cap Rubber Cleaning"(P. 120). 2. Perform the procedure described in ☞ "Carriage Underside Cleaning"(P. 121). 3. Perform the procedure described in ☞ "Head Cleaning"(P. 93). 4. Set auto maintenance. ☞ "Maintenance Menu"(P. 107)
Nozzles are clogged.	<ol style="list-style-type: none"> 1. Perform the procedure described in ☞ "Head Cleaning"(P. 93). 2. Perform the procedure described in ☞ "Print Head Nozzle Washing"(P. 162). 3. Perform the procedure described in ☞ "Registering Nozzle Recovery"(P. 109).
Are the print heads too high?	Adjust the print head height. ☞ "Adjusting Print Head Height"(P. 60) If the print heads cannot be lowered, increase the refresh level during printing (☞ P. 107) or perform regular test printing to check for nozzle clogging.
Are there any ink colors that aren't used much?	Discharge from infrequently used nozzles tends not to be consistent. Although increasing the refresh level during printing (☞ P. 107) will enable more frequent nozzle use, note that this will also increase ink consumption.
Are you using media easily affected by static electricity?	Increase the refresh level during printing (☞ P. 107) or perform regular test printing to check for nozzle clogging.
Is the machine installed in a location with low humidity?	Increase the humidity by installing a humidifier or similar equipment. When printing continuously, also increase the refresh level during printing (☞ P. 107) or perform regular test printing to check for nozzle clogging.
Is the machine installed in a location where dust or powder is present?	Install the machine in a location free of dust or powder (office equivalent: dust level 0.15 mg/m ³).
Dirty black spots are adhering.	<ol style="list-style-type: none"> 1. Perform the procedure described in ☞ "Tension Roller Cleaning"(P. 131). 2. Clean the sublimation transfer machine being used.

Print Head Nozzle Washing

If ejection failures (e.g., nozzle clogging or deflection) remain unresolved even after head cleaning (☞ "Head Cleaning"(P. 93)), apply nozzle wash to the print head.

- 1** On the LOCAL mode screen, select [MENU] > [Maintenance], then press the [ENTER] key.
 - The Maintenance menu is displayed.
- 2** Select [Station Maint.] > [Nozzle Wash], then press the [ENTER] key.
 - The carriage moves over the platen.
- 3** Open the maintenance cover on the right side.
- 4** Clean the cap rubber.
 - ☞ "Cap Rubber Cleaning"(P. 120)
- 5** Once cleaning is complete, close the cover, then press the [ENTER] key.
 - The cap is filled with maintenance liquid.



- Close the cover. The cap cannot be filled with maintenance liquid while the cover is open. This is also true if the maintenance liquid cartridge is empty.

- 6** Open the maintenance cover on the right side.
 - (1) Remove the two screws at the bottom of the right maintenance cover.
 - (2) Hold the bottom edge of the maintenance cover, then pull out and forward to remove.

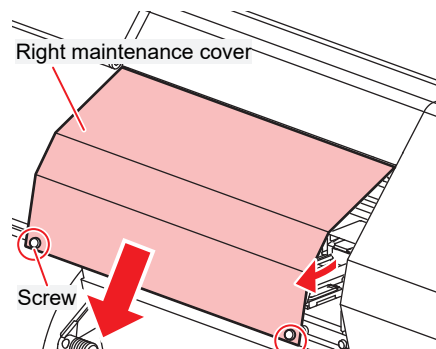

- Check to confirm that the cap is filled with maintenance liquid.



- If not, use a syringe to draw up some maintenance liquid and fill until it almost overflows from the cap.

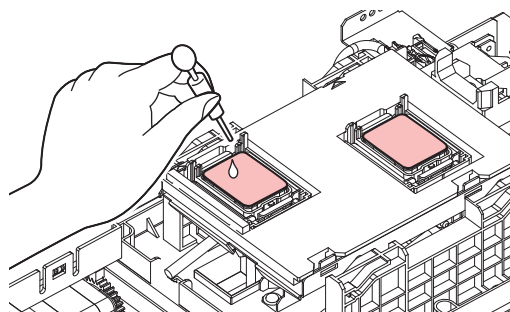

- 7** Close the maintenance covers.

8 Set the exposure time, then press the [ENTER] key.



- Cleaning is performed automatically once print nozzle washing has ended.



- If ejection failures (e.g., nozzle clogging or deflection) remain unresolved even after washing the nozzles several times, contact your local dealer or our service office.

The heater temperature does not rise to the specified value.

This may indicate a problem with the setting.

Points to check	Corrective action
Is the heater temperature set?	Set the heater temperature.  "Setting the Heater Temperature"(P. 90)  "Media Setting Menu"(P. 104)

The ink has leaked out



- If an ink leak occurs, turn off the main power immediately and unplug the power cable. Then, contact your local dealer or our service office.











5.2 Problems Causing Messages to Appear

If a problem arises, the buzzer sounds and a message appears on the display.

You can also check the local guidance.  ["Displaying Machine Information \(Local Guidance\)"\(P. 32\)](#)

Take the appropriate action in accordance with the content of the message. If a message reappears even after taking the prescribed action, contact your local dealer or our service office.







Warning Messages

Message	Cause	Corrective action
Ink Error	<ul style="list-style-type: none"> An ink error occurred. 	<ul style="list-style-type: none"> Check the ink error details.  "Ink error"(P. 165)
COVER OPEN	<ul style="list-style-type: none"> The cover is open. 	<ul style="list-style-type: none"> Close the cover.
Lower the clamp lever	<ul style="list-style-type: none"> The clamp lever is raised. 	<ul style="list-style-type: none"> Lower the clamp lever.  "Front"(P. 22)
Data Remain	<ul style="list-style-type: none"> Print (RIP) data was received. 	<ul style="list-style-type: none"> Switch to REMOTE mode and start printing or clear the data and abort printing.
Temporary Suspension	<ul style="list-style-type: none"> Printing has been paused. 	<ul style="list-style-type: none"> Switch to REMOTE mode and resume printing or clear the data and abort printing.
Printing not possible/ink IC	<ul style="list-style-type: none"> An unusable ink IC chip is used. 	<ul style="list-style-type: none"> Replace with new ink and a new ink IC chip.  "Replacing Ink"(P. 42)
No Media	<ul style="list-style-type: none"> No media is loaded, or the sensors are faulty. 	<ul style="list-style-type: none"> Load the media.  "Loading the Media"(P. 68) Clean the media sensor.  "Media Sensor Cleaning"(P. 127)
Please load media	<ul style="list-style-type: none"> No media is loaded, or the sensors are faulty. 	<ul style="list-style-type: none"> Load the media.  "Loading the Media"(P. 68)
Media Undetected	<ul style="list-style-type: none"> The media width has not been detected. 	<ul style="list-style-type: none"> Detect the media width.  "Loading the Media"(P. 68)
Wiper Move Failure	<ul style="list-style-type: none"> The wiper is not operating correctly. 	<ol style="list-style-type: none"> Clean the wiper and around the wiper.  "Wiper Cleaning"(P. 122) Turn off the main power and wait a while before turning back on.  "Turning Off the Power"(P. 35)
Check Waste Ink tank	<ul style="list-style-type: none"> Seven days have elapsed since the waste ink tanks were last checked. 	<ol style="list-style-type: none"> Check the waste ink levels in the waste ink tanks on the left and right sides. Replace the waste ink tanks if they are full of waste ink.  "Replacing the Waste Ink Tank"(P. 156)
WashLiquidCart.None	<ul style="list-style-type: none"> No maintenance liquid cartridge is loaded. 	<ul style="list-style-type: none"> Load the maintenance liquid cartridge.
Please replace wash liquid cartridge	<ul style="list-style-type: none"> The maintenance liquid has run out. 	<ul style="list-style-type: none"> Replace with a new maintenance liquid cartridge.
Washing liquid end	<ul style="list-style-type: none"> The maintenance liquid has run out. 	<ul style="list-style-type: none"> Replace with a new maintenance liquid cartridge.

Message	Cause	Corrective action
High ambient temp ** ° C	<ul style="list-style-type: none"> Ambient temperatures are too high. 	<ul style="list-style-type: none"> Adjust ambient temperatures to temperatures within the specified range. Optimum print quality may not be possible unless ambient conditions are within the specified range. "Installation Precautions"(P. 16)
Low ambient temp ** ° C	<ul style="list-style-type: none"> Ambient temperatures are too low. 	
Auto-correction failed	<ul style="list-style-type: none"> White media is not used. The media is dirty. The media lifts up. There is dirt around the sensor. 	<ul style="list-style-type: none"> Load white and clean media. Load media so it does not lift up. Clean the area around the sensor. "DAS (Automatic Correction Function) Sensor Cleaning"(P. 124) If automatic correction fails repeatedly, correct the position manually. "Feed Correction"(P. 94) "Correcting the Drop Position"(P. 96)
Replace Wiper	<ul style="list-style-type: none"> The wiping count exceeded the preset value. 	<ul style="list-style-type: none"> Replace the wiper, then reset the count. "Wiper Replacement"(P. 136)
Take-Up LimitDetect	<ul style="list-style-type: none"> The take-up tension bar was detected at the upper limit position. 	<ul style="list-style-type: none"> Lower the take-up tension bar.
Feeding LimitDetect	<ul style="list-style-type: none"> The feed tension bar was detected at the upper limit position. 	<ul style="list-style-type: none"> Lower the feed tension bar.
Take-up Wrong	<ul style="list-style-type: none"> The take-up tension bar has not moved from the lower limit position. 	<ul style="list-style-type: none"> Use the JOG key to confirm that the take-up unit operates correctly.
Feeding Wrong	<ul style="list-style-type: none"> The feed tension bar has not moved from the lower limit position. 	<ul style="list-style-type: none"> Use the JOG key to confirm that the feeding unit operates correctly.
Take-up Cover Open	<ul style="list-style-type: none"> A take-up unit cover is open. 	<ul style="list-style-type: none"> Close the take-up unit cover.
Feeding Cover Open	<ul style="list-style-type: none"> A feeding unit cover is open. 	<ul style="list-style-type: none"> Close the feeding unit cover.
No Platen	<ul style="list-style-type: none"> No platens are mounted on the machine. 	<ul style="list-style-type: none"> Attach the platens, then print. "Selecting the Platens"(P. 52)

Ink error









Message	Cause	Corrective action
Ink End	<ul style="list-style-type: none"> The ink has run out. 	<ul style="list-style-type: none"> Replace with new ink. "When Ink End is Displayed"(P. 41) If you use UISS, you may perform cleaning.
Ink Near End	<ul style="list-style-type: none"> Ink levels are low. 	<ul style="list-style-type: none"> The ink will run out soon. Have new ink ready. "When Ink Near End is Displayed"(P. 41)
Non Ink IC	<ul style="list-style-type: none"> No ink IC chip was detected. 	<ol style="list-style-type: none"> Insert the ink IC chip. "Replacing Ink"(P. 42)











Message	Cause	Corrective action
		<ol style="list-style-type: none"> 2. Check to confirm the ink IC chip was inserted correctly.  "Mounting the ink"(P. 45) 3. Turn off the main power and wait a while before turning back on.
Wrong Ink IC	<ul style="list-style-type: none"> • An error occurred with the information on the ink IC chip. 	<ol style="list-style-type: none"> 1. Check to confirm the ink IC chip was inserted correctly.  "Mounting the ink"(P. 45) 2. Turn off the main power and wait a while before turning back on. 3. Replace with new ink.  "Replacing Ink"(P. 42)
Ink Color	<ul style="list-style-type: none"> • The ink color registered on the IC chip is different from the ink color filled. 	<ul style="list-style-type: none"> • Insert an ink IC chip for the correct ink color.  "Mounting the ink"(P. 45)
Ink Type	<ul style="list-style-type: none"> • The ink type registered on the IC chip is different from the ink type filled. 	<ul style="list-style-type: none"> • Insert an ink IC chip for the correct ink type.  "Mounting the ink"(P. 45)
Expiration Near	<ul style="list-style-type: none"> • The ink has expired. 	<ul style="list-style-type: none"> • Replace with new ink or use up as quickly as possible. Printing is possible.  "When Ink End is Displayed"(P. 41)
Expiration Over	<ul style="list-style-type: none"> • The ink is two months past its expiration date and cannot be used. 	<ul style="list-style-type: none"> • Replace with new ink. Printing is not possible.  "When Ink End is Displayed"(P. 41)

Error Message



Error number	Message	Cause	Corrective action
04	PARAM ROM	<ul style="list-style-type: none"> • A problem was detected with the main PCB. 	<ul style="list-style-type: none"> • Turn off the main power and wait a while before turning back on.
108	HD THERMIS[12]	<ul style="list-style-type: none"> • A problem was detected with print head temperature control. 	
108	HD CONNECT[12]	<ul style="list-style-type: none"> • A problem was detected with the print head connection. 	
108	HD MEM EMP[12]	<ul style="list-style-type: none"> • A problem was detected with the print head. 	
10e	FROM CLEAR	<ul style="list-style-type: none"> • A problem was detected with the main PCB. 	
10f	FROM WRITE		
115	PCB MAIN-F1		
122	CHECK:SDRAM	<ul style="list-style-type: none"> • A problem was detected with the SDRAM. 	
122	PRAM NONE		
123	PRAM DATA	<ul style="list-style-type: none"> • A problem was detected with the main PCB. 	
124	PRAM ADDR		
127	POWER OFF		





Error number	Message	Cause	Corrective action
128	HDC FIFO OVER	<ul style="list-style-type: none"> A problem was detected with the print head control PCB. 	
128	HDC FIFO UNDER		
129	Battery Exchange	<ul style="list-style-type: none"> The internal clock battery is spent and must be replaced. 	<ul style="list-style-type: none"> Contact your local dealer or our service office.
12a	HDC SPEED	<ul style="list-style-type: none"> A problem was detected with the print head control. 	<ul style="list-style-type: none"> Turn off the main power and wait a while before turning back on.
12d	PCB MAIN-F4	<ul style="list-style-type: none"> A problem was detected with the main PCB. 	
130	HD DATA SEQ	<ul style="list-style-type: none"> A problem was detected with the print head control. 	
147	DS-IC BUSY	<ul style="list-style-type: none"> Ink IC control abnormality detected. 	
148	E-LOG SEQ	<ul style="list-style-type: none"> A log control abnormality was detected. 	
151	Main PCB V1R2	<ul style="list-style-type: none"> A problem was detected with the main PCB power supply circuit. 	
152	Main PCB V2R5		
153	Main PCB V3R3		
154	Main PCB V05		
155	Main PCB V42-1		
15f	HEAD DRIVE HOT	<ul style="list-style-type: none"> The HDCE PCB COM driver is hot. 	
171	NEW HEAD CONNECT	<ul style="list-style-type: none"> A new print head connection was detected. 	
17e	PCB IIO	<ul style="list-style-type: none"> A communication error was detected between the boards. 	
186	HDC OVERFLOW/HDC UNDERFLOW	<ul style="list-style-type: none"> A problem was detected with the print head control. 	
187	HDC SLEW RATE		
188	HDC MEMORY		
18c	Main PCB V12	<ul style="list-style-type: none"> A problem was detected with the main PCB power supply. 	
18e	FLS NOT COMP	<ul style="list-style-type: none"> A problem was detected with the print head control. 	
18f	OFFSET START [12]		
18f	OFFSET END [12]		
1b5	SLIDER CONNECT	<ul style="list-style-type: none"> Unable to detect the HDCE PCB. 	<ul style="list-style-type: none"> Turn off the main power and wait a while before turning back on.  "Turning Off the Power"(P. 35)
1bf	PCB MAIN-F2	<ul style="list-style-type: none"> A problem was detected with the main PCB. 	
1c5	PCB IIO-F*	<ul style="list-style-type: none"> A blown fuse on the ink supply 2LC PCB was detected. 	

Error number	Message	Cause	Corrective action
1d8	HEAD XHOT[12]	<ul style="list-style-type: none"> A problem was detected with the print head. 	
1e6	PRAM Size Shortage	<ul style="list-style-type: none"> Insufficient memory 	
201	Command Error	<ul style="list-style-type: none"> Data other than print (RIP) data was received, or a problem was detected with the print (RIP) data received. 	<ol style="list-style-type: none"> Clear the data and resend. Check the USB/Ether cable connection.  "Connecting a PC to the Product"(P. 36) Use a compatible cable.  "Connecting a PC to the Product"(P. 36)
202	Parameter Error	<ul style="list-style-type: none"> A problem was detected with the print (RIP) data received. 	<ol style="list-style-type: none"> Turn off the main power and wait a while before turning back on.  "Turning Off the Power"(P. 35)
206	Print Mode Error	<ul style="list-style-type: none"> Print (RIP) data was received with print parameters that do not allow printing. 	<ul style="list-style-type: none"> Change the output parameters and profile using RIP software.
20A	Driver Version	<ul style="list-style-type: none"> Printing is not possible because the Mimaki driver version is old. 	<ul style="list-style-type: none"> Install the latest Mimaki driver available from: https://mimaki.com/download/inkjet.html
303	PCB MAIN ET	<ul style="list-style-type: none"> A problem was detected with the main PCB. 	<ol style="list-style-type: none"> Turn off the main power and wait a while before turning back on.
304	USB INIT ERR	<ul style="list-style-type: none"> A problem was detected with the USB cable connection. 	<ol style="list-style-type: none"> Check the USB cable connection.  "Using a USB Cable"(P. 37) Use a compatible cable.  "Using a USB Cable"(P. 37) Turn off the main power and wait a while before turning back on.  "Turning Off the Power"(P. 35)
305	USB TIME OUT		
318	SDcard Connection ERR	<ul style="list-style-type: none"> A problem was detected with the SD card. 	<ol style="list-style-type: none"> Turn off the main power and wait a while before turning back on.  "Turning Off the Power"(P. 35)
401	Motor X	<ul style="list-style-type: none"> The X motor was overloaded. 	<ol style="list-style-type: none"> Check to confirm the media is loaded correctly.  "Loading the Media"(P. 68) Open the front cover and check for anything that may obstruct carriage movement. Turn off the main power and wait a while before turning back on.  "Turning Off the Power"(P. 35)
402	Motor Y	<ul style="list-style-type: none"> The Y motor was overloaded. 	
403	X Current	<ul style="list-style-type: none"> An overcurrent error was detected in the X motor. 	
404	Y Current	<ul style="list-style-type: none"> An overcurrent error was detected in the Y motor. 	
406	Wiper Move Failure	<ul style="list-style-type: none"> The wiper origin could not be detected. 	<ol style="list-style-type: none"> Clean the wiper and around the wiper.  "Wiper Cleaning"(P. 122) Turn off the main power and wait a while before turning back on.  "Turning Off the Power"(P. 35)
423	Take-up Tension-bar	<ul style="list-style-type: none"> Take-up tension bar position initialization failed. 	<ol style="list-style-type: none"> Lower the take-up tension bar. Check which way the take-up unit rotation direction switch is set.  "Take-up unit"(P. 69) Check to confirm the media is loaded correctly.

Error number	Message	Cause	Corrective action
424	Feed tension bar	<ul style="list-style-type: none"> Feed tension bar position initialization failed. 	<ol style="list-style-type: none"> Lower the feed tension bar. Check which way the feeding unit rotation direction switch is set.  "Feeding unit"(P. 72) Check to confirm the media is loaded correctly.
425	Take-up Wrong	<ul style="list-style-type: none"> The take-up tension bar has not moved from the lower limit position. 	<ol style="list-style-type: none"> Check which way the take-up unit rotation direction switch is set. Check to confirm the media is loaded correctly.
426	Feeding Wrong	<ul style="list-style-type: none"> The feed tension bar has not moved from the lower limit position. 	<ol style="list-style-type: none"> Check which way the feeding unit rotation direction switch is set. Check to confirm the media is loaded correctly.
427	Take-up Cover Open	<ul style="list-style-type: none"> A take-up unit cover is open. 	<ul style="list-style-type: none"> Close the take-up unit cover.
428	Feeding Cover Open	<ul style="list-style-type: none"> A feeding unit cover is open. 	<ul style="list-style-type: none"> Close the feeding unit cover.
429	Take-Up LimitDetect		
42a	Feeding LimitDetect		
48b	Y MOTOR COM	<ul style="list-style-type: none"> Y motor communication is not possible. 	<ul style="list-style-type: none"> Turn off the main power and wait a while before turning back on.  "Turning Off the Power"(P. 35)
48c	Y MTR I2C COM	<ul style="list-style-type: none"> Y motor communication is not possible at startup. 	
496	Y MOTOR DIR	<ul style="list-style-type: none"> The Y motor operating direction cannot be specified. 	<ul style="list-style-type: none"> Turn off the main power and wait a while before turning back on.  "Turning Off the Power"(P. 35)
504	CLAMP UP	<ul style="list-style-type: none"> The clamp lever is lifted. 	<ul style="list-style-type: none"> Lower the clamp lever.
505	Media Jam	<ul style="list-style-type: none"> The media jam sensor was triggered. 	<ol style="list-style-type: none"> Remove the media in contact with the carriage and reload with fresh media.  "Loading the Media"(P. 68) Open the front cover and check for anything that may obstruct carriage movement.
509	HDC POSCNT	<ul style="list-style-type: none"> A problem was detected with position control. 	<ul style="list-style-type: none"> Turn off the main power and wait a while before turning back on.  "Turning Off the Power"(P. 35)
50a	Y Org Detect Error	<ul style="list-style-type: none"> A problem was detected with Y origin detection (initialization). 	
50c	Check Media With Sensor	<ul style="list-style-type: none"> A problem was detected with media width detection. 	<ol style="list-style-type: none"> Check the media loading position.  "Loading the Media"(P. 68) Clean the media width sensor.  "Media Sensor Cleaning"(P. 127)
50f	L-SCALE BLACK	<ul style="list-style-type: none"> A problem was detected with the linear scale. 	<ul style="list-style-type: none"> Turn off the main power and wait a while before turning back on.  "Turning Off the Power"(P. 35)
516	Media Set Position R (L)	<ul style="list-style-type: none"> The media was loaded outside the range of valid positions. 	<ol style="list-style-type: none"> Check the media loading position.  "Loading the Media"(P. 68) Clean the media width sensor.  "Media Sensor Cleaning"(P. 127)

Error number	Message	Cause	Corrective action
54b	Media Press	<ul style="list-style-type: none"> Media retainer detection failed. 	<ol style="list-style-type: none"> Check the media loading position. "Loading the Media"(P. 68) Clean the media width sensor. "Media Sensor Cleaning"(P. 127)
54c	Vacuum Fan Err	<ul style="list-style-type: none"> A problem was detected with the vacuum fan. 	<ul style="list-style-type: none"> Turn off the main power and wait a while before turning back on. "Turning Off the Power"(P. 35)
602	Ink End	<ul style="list-style-type: none"> The ink has run out. 	<ul style="list-style-type: none"> Replace with new ink. "When Ink End is Displayed"(P. 41)
608	Wrong Ink IC	<ul style="list-style-type: none"> An error occurred with the information on the ink IC chip. 	<ol style="list-style-type: none"> Check to confirm the ink IC chip was inserted correctly. "Mounting the ink"(P. 45) Turn off the main power and wait a while before turning back on. "Turning Off the Power"(P. 35) Replace with new ink. "Replacing Ink"(P. 42)
60a	Excess Ink Usage	<ul style="list-style-type: none"> The ink usage amount stored in the ink IC chip exceeded the preset value. The ink IC chip was not replaced during ink replacement. (The same chip continued to be used.) The machine was used with nozzle clogging. 	<ul style="list-style-type: none"> Replace with new ink. "When Ink End is Displayed"(P. 41)
60c	Ink Type	<ul style="list-style-type: none"> The ink type registered on the IC chip is different from the ink type filled. 	<ul style="list-style-type: none"> Insert an ink IC chip for the correct ink type. "Mounting the ink"(P. 45)
61b	Ink supply	<ul style="list-style-type: none"> Ink cannot be supplied. 	<ul style="list-style-type: none"> Turn off the main power and wait a while before turning back on. "Turning Off the Power"(P. 35)
627	Set Eco-cases	<ul style="list-style-type: none"> The ink IC chip could not be read for a certain period of time. 	<ol style="list-style-type: none"> Check to confirm the ink IC chip was inserted correctly. Turn off the main power and wait a while before turning back on. "Turning Off the Power"(P. 35)
629	Expiration Near	<ul style="list-style-type: none"> The ink has expired. 	<ul style="list-style-type: none"> Replace with new ink or use up as quickly as possible. Printing is possible. "When Ink End is Displayed"(P. 41)
62a	Expiration Over	<ul style="list-style-type: none"> The ink is two months past its expiration date and cannot be used. 	<ul style="list-style-type: none"> Replace with new ink. Printing is not possible. "When Ink End is Displayed"(P. 41)
631	Ink Color	<ul style="list-style-type: none"> The ink color registered on the IC chip is different from the ink color filled. 	<ul style="list-style-type: none"> Insert an ink IC chip for the correct ink color. "Mounting the ink"(P. 45)
637	INK LEAK _	<ul style="list-style-type: none"> The ink leak sensor detected an ink leak. 	<ul style="list-style-type: none"> Contact your local dealer or our service office.

Error number	Message	Cause	Corrective action
659	Less Supply	<ul style="list-style-type: none"> There is a problem with the ink supply. 	<ol style="list-style-type: none"> Check to confirm that there is sufficient ink in the ink pack for the path where the error occurred. Check to confirm that the ink pack for the path where the error occurred is not bent over. Use [Maintenance] > [Ink Supply Maint.] to check that the error clears.
702	Thermistor Connect	<ul style="list-style-type: none"> A problem was detected with the thermistor connection. 	<ul style="list-style-type: none"> Turn off the main power and wait a while before turning back on.  "Turning Off the Power"(P. 35)
703	Heater Brk	<ul style="list-style-type: none"> A problem was detected with the heater temperature. 	
710	Heater Temp Error	<ul style="list-style-type: none"> A problem was detected with the heater temperature. 	<ul style="list-style-type: none"> This error will be automatically resolved. If the error is not resolved, turn off the main power and wait a while before turning back on.  "Turning Off the Power"(P. 35)
801	(C) OPCODE	<ul style="list-style-type: none"> A problem was detected with the main PCB. 	<ul style="list-style-type: none"> Turn off the main power and wait a while before turning back on.  "Turning Off the Power"(P. 35)
802	(C) SWI		
803	(C)PFTCHABRT		
804	(C)DATAABRT		
806	FW/SIO bit	<ul style="list-style-type: none"> A communication error was detected between the boards. 	
808	FW/STP-MTR**	<ul style="list-style-type: none"> A problem was detected with the main PCB. 	
80f	FW/SIO Vch	<ul style="list-style-type: none"> A communication error was detected between the boards. 	
811	FW/SIO read	<ul style="list-style-type: none"> A communication error was detected between the boards. 	
81b	FW/STACK OV	<ul style="list-style-type: none"> A problem was detected with the main PCB. 	
828	PRG ERR L*****		
901	Operation Error	<ul style="list-style-type: none"> The function is disabled due to an error. 	<ul style="list-style-type: none"> Check the error details. <ul style="list-style-type: none"> Media Undetected Ink error Waste ink tank, etc.
902	Data Remain	<ul style="list-style-type: none"> Print (RIP) data was received. 	<ul style="list-style-type: none"> Switch to REMOTE mode and start printing or clear the data and abort printing.
90f	Print Area Short	<ul style="list-style-type: none"> The media is too small for the print. 	<ul style="list-style-type: none"> Replace with wider or longer media. If the printable area is reduced due to a shift in the origin, move the origin to increase the size of the printable area.

Error number	Message	Cause	Corrective action
b1a	PCB BaseIO	<ul style="list-style-type: none"> A communication error was detected between the boards. 	<ul style="list-style-type: none"> Turn off the main power and wait a while before turning back on.  "Turning Off the Power"(P. 35)
b1b	BaseIO PCB Vpow-s	<ul style="list-style-type: none"> A problem was detected with the Base IO PCB power supply. 	
b1c	BaseIO PCB V24		
b1d	BaseIO PCB V24-A		
b1e	PCB BaseIO-F**	<ul style="list-style-type: none"> The Base IO PCB fuse blow was detected. 	<ul style="list-style-type: none"> The fuse must be replaced. Contact your local dealer or our service office.
b37	PCB WFIO	<ul style="list-style-type: none"> A communication error was detected between the boards. 	<ul style="list-style-type: none"> Turn off the main power and wait a while before turning back on.  "Turning Off the Power"(P. 35)
b39	PCB WFIO-F*	<ul style="list-style-type: none"> A blown fuse on the WFIO PCB was detected. 	
b3f	BaseIO Unconform	<ul style="list-style-type: none"> The PCB could not be detected. 	
b48	PCB HDCE*	<ul style="list-style-type: none"> A communication error was detected between the boards. 	<ul style="list-style-type: none"> Turn off the main power and wait a while before turning back on.  "Turning Off the Power"(P. 35)
b49	PCB HDCE-VHVFET[12]	<ul style="list-style-type: none"> A problem was detected with the HDCE PCB power supply. 	
b4a	PCB HDCE*-F*	<ul style="list-style-type: none"> A blown fuse on the HDCE PCB was detected. 	<ul style="list-style-type: none"> Contact your local dealer or our service office.
b4b	HDCE* PCB V1R2	<ul style="list-style-type: none"> A problem was detected with the HDCE PCB power supply. 	<ul style="list-style-type: none"> Turn off the main power and wait a while before turning back on.  "Turning Off the Power"(P. 35)
b4c	HDCE* PCB V2R5		
b4d	HDCE* PCB V3R3		
b51	BaseIO PCB V24adj	<ul style="list-style-type: none"> A problem was detected with the Base IO PCB power supply. 	
b63	IIO PCB V3R3	<ul style="list-style-type: none"> A problem was detected with the ink supply 2LC PCB power supply. 	<ul style="list-style-type: none"> Turn off the main power and wait a while before turning back on.  "Turning Off the Power"(P. 35)
b64	IIO PCB V2R5		
d1b	COM VOLT[12]	<ul style="list-style-type: none"> A problem was detected with the HDCE PCB voltage. 	

SYSTEM HALT



- If a SYSTEM HALT number is displayed, turn off the main power and wait a while before turning back on.

Chapter 6 Appendix



This chapter

This chapter describes the machine specifications.

6.1 Specifications

Item		TS330-3200DS
Print head	Type	On-demand piezo head
	Specifications	Two staggered heads with 400 nozzles × 8 rows each
	Resolution	Y
X		600 dpi, 1,200 dpi
Ink type		Sb420, Sb411
Ink set	4-color	BL, M, Y, K (UISS)
Media	Type	Decalcomania paper, fabric
	Maximum printing width ^{*1}	3,240 mm
	Maximum width	3,250 mm
	Minimum width	210 mm
	Thickness	Max. 1.0 mm
	Roll external diameter ^{*2}	Max. 250 mm
	Roll weight ^{*2, 3}	Max. 100 kg
	Paper core internal diameter	3 inches
	Printing face	Exterior
	Roll end	Taped or loosely affixed to paper core
Print margins	Left/right	20 mm (default), minimum: Left/right 5 mm
	Top end	70 mm (default), minimum: Left/right 10 mm
	Bottom end	70 mm (default), minimum: Left/right 10 mm
Distance accuracy ^{*4}	Absolute accuracy	±1.5 mm or ±0.3 % of specified distance, whichever is greater
	Duplicability	±1.5 mm or ±0.1 % of specified distance, whichever is greater
Perpendicularity		±0.5 mm/1,000 mm
Media skew		Not more than 5 mm/10 m
Printing gap		Manual, three settings (3.0, 3.5, 4.0 mm)
Origin alignment		LED pointer
Ink supply		Ink eco-case (ink pack)
Maintenance liquid feed		Cartridge
Waste Ink Tank		Tank type (10 L)
Take-up unit		Selectable inside/outside winding
Media heater		POST
DAS (Automatic correction function)		Provided

Item		TS330-3200DS	
Interface	Data transfer function	Ethernet 1000BASE-T (recommended) ^{*5, 6} , USB 2.0 Hi-speed ^{*6, 7}	
Command		MRL-V	
Running flushing		Weak: 400 / Standard: 600 / Strong: 800	
Languages		English, Japanese, Chinese, Turkish, Portuguese, Spanish, Italian	
Noise levels	During standby	Not more than 53 dB (FAST-A, 1 m on all sides)	
	Continuous operation	Not more than 64 dB (FAST-A, 1 m on all sides)	
	Non-continuous operation	Not more than 64 dB (FAST-A, 1 m on all sides)	
Compliance with standards		VCCI Class A, FCC Class A, IEC 62368-1 ETL compliance, CE marking (EMC Directive, Low Voltage Directive, Machinery Directive, RoHS Directive), CB certified, REACH, RCM marking, KC certified, UKCA marking	
Power supply specifications ^{*8}		Single-phase 200 to 240 V AC $\pm 10\%$ /10 A, 50/60 Hz ± 1 Hz $\times 1$	
Power consumption	Maximum ^{*9}	Inlet 1	200 to 240 V AC: Max. 2,400 W
	Standard	Inlet 1	900 W
	Minimum ^{*10}	Inlet 1	4.5 W or less
Installation environment ^{*11}	Permissible ambient temperature	20 to 30 °C	
	Relative humidity	35 to 65 %RH (no condensation)	
	Temperature range in which accuracy is guaranteed	20 to 25 °C	
	Temperature gradient	Not more than ± 10 °C/h	
	Dust	0.15 mg/m ³ (typical office)	
	Maximum operating altitude	2,000 m	
External dimensions ^{*12}	Width	5,410 mm (5,750 mm)	
	Depth	1,075 mm (1,140 mm)	
	Height	1,650 mm (2,080 mm)	

Item	TS330-3200DS
Weight ^{*12}	Main unit: 925 kg, external supply unit: 43 kg

- *1. With setup menu margins set to the minimum (5 mm) on either side.
- *2. External diameter and weight after winding media.
- *3. Free of sagging due to weight.
- *4. Excluding media size variation and initial loading fluctuations.
- *5. Printing is not possible if local guidance shows any speed other than "1000Mbps". Using a LAN Cable
- *6. The print speed may be decreased depending on the connection environment or print data. Connecting a PC to the Product
- *7. Data may be transferred to the machine too slowly, causing the carriage to pause at the left-hand or right-hand end during printing.
- *8. Excluding options.
- *9. Varies depending on print mode.
- *10. In sleep.
- *11. Ink ejection consistency may decrease in conditions outside this range.
- *12. The figures in parentheses indicate package dimensions. Excluding the external supply unit.

6.2 Options

Name	Code	Reference page
10 kg ink supply unit 2	OPT-J0575	Separate operating manual (D203605-20 onward)

Index

A

Air PG	108
Auto Cleaning	108
Auto Maint.	22, 23, 107
Auto Power-off.....	111
Auto Power-on.....	111
Auto Remote	112
Auto-correction (DAS)	104, 165

C

Cancel	30
Cap	26, 119, 120, 139
Cap absorber.....	141
Cap Replacement.....	107, 115
Capping Use Days	115
Carriage.....	22, 26, 30, 107, 119, 121
Carriage Out.....	107
Clamp lever	22, 24
Cleaning	93, 107
Cloth holder	149
Color profile	39
Custody Wash	107, 133

D

DAS (Dot Adjustment System)	104, 119, 124
Delete MediaInfo	106
Detail Setting	105
DISCLAIMERS	6
Display.....	30, 31
Display language.....	113
Drop.PosCorrect.....	32, 50, 96, 104
Drying Time	111

E

Ejection failures	91, 93, 107, 109, 122, 139, 160
[END/POWER] key.....	29, 30, 34
[ENTER] key.....	30
Environment Setting Menu	113
Error.....	30, 164

Error History	115
Exhaust fan BOX.....	24, 144
<hr/> F <hr/>	
FCC	6
Feed Comp.....	32, 50, 94, 104
Feed Speed	106
Feeding unit.....	24, 72
Flushing unit	22
Front cover	23
[FUNCTION] key	30, 32
Function Setting Menu	111
<hr/> G <hr/>	
Grit roller.....	22, 27, 119
<hr/> H <hr/>	
Head Cleaning.....	30
Head height	60
Heater.....	29, 90, 105, 163
Height adjustment lever.....	60
<hr/> I <hr/>	
Ink absorber	43, 155
Ink discharge channel	119, 126
Ink Eco-case.....	25, 42, 44, 45
Ink End	41, 108
Ink error	31
Ink IC chip	25, 42, 43, 45, 46
Ink IC chip slot.....	25, 45
Ink leak check tube.....	25
Ink lever.....	25
INK NEAR-END.....	41
Ink pack	42, 43
Ink replacement.....	115
Ink status	31
Ink Supply Maint.....	108
Ink Supply Unit	25, 43, 155
Inlet.....	24
Installation guide	39, 40
Installation Space	17
Interference	6

interlock	18
<hr/> J <hr/>	
Jam sensor	22, 119, 129
[JOG] key	30
<hr/> K <hr/>	
Key Buzzer	113
KeyLife	114
<hr/> L <hr/>	
LAN cable	24, 36
LAN port	24
LANGUAGE	113
List	115
Local guidance	32
LOCAL mode	30, 31
Logical Seek	111
<hr/> M <hr/>	
Machine Status Menu	115
Main power switch	24, 29, 34
Maintenance	115
Maintenance cover	22
Maintenance History	115
Maintenance liquid absorber	141
Maintenance liquid cartridge	24
Maintenance Menu	107
MAPS (Mimaki Advanced Pass System)	104
Margin	112
Media	68
Media cutter	22
Media feed	30
Media holder	119, 128, 130, 149
Media Information	105
Media Name Change	106
Media Remain	105
Media Sensor	24, 28, 119, 127
Media Setting Menu	104
Media setting position plate	72
Media Width	105
MENU mode	31

Mimaki driver	39
Mist exhaust unit	22
MRA (Mimaki Remote Access).....	113
<hr/> N <hr/>	
Network	113
NOT-READY mode	31
Nozzle clogging	93
Nozzle Deflection	93
Nozzle Recovery	107, 109
Nozzle Wash	107, 162
<hr/> O <hr/>	
Operating Panel	22, 30
Option Roll Unit Select	111
<hr/> P <hr/>	
PIN code.....	114
Pinch roller	22, 27, 119, 148
Platen	22, 27, 119, 130
Post-heater	22, 90
Power Setting	111
Pre Feed.....	106
Print Area	115
Print Length	115
Print Maint.	108
Print origin	100
Pump Tube Cleaning.....	107, 126
<hr/> R <hr/>	
RasterLink	39, 40, 98, 99, 111, 112
Receive buffer	102
Reference guide	99
Refresh.....	108
Remaining ink.....	31
Remote Control	113
REMOTE mode	30, 31
Replace Wiper.....	61, 107, 115, 136
<hr/> S <hr/>	
[SEL] key	30
Smoothing Level.....	105

Space Btwn PP.	112
Space Feed Mode	112
Station	22, 26
Station Maint.	107
Status lamp	30
Switching hub	36
Symbol	8
SYSTEM HALT	31

T

Take-up unit	22, 69
Tension roller.....	22, 111
Test printing.....	30, 91, 107
Time Set	113

U

Unit Setting	113
Usage	115
USB interface cable.....	24, 37
USB port.....	24
Use Time	115

V

Vacuum Fan	105
Version	115
View Feed	112

W

Warning Label	19
Waste ink tank	119, 156
Waste Ink Tank	22
WhiteSpace Setting	112
Wiper	26, 61, 107, 122, 136
Wiper cleaner	137
WIPING	115

MEMO



Operation manual

Feb, 2025

MIMAKI ENGINEERING CO.,LTD.

2182-3 Shigeno-otsu, Tomi-shi, Nagano 389-0512 JAPAN

D203845-11-06022025

